

Over 40 New Products in this Catalogue

Relief Cartridge Valves

Page 9: The **RP*S** is a seated style pilot operated relief valve. This provides reduced leakage, faster response and a reduced pressure overshoot to give improved pressure control.

Page 10: The **RP*GT** is a "soft start" relief valve available in series 2 only providing a pressure ramping over 300 milliseconds when it opens to provide excellent pressure protection and reduce shock.

Page 13: The **RBAP** is an electro-proportional, direct acting pilot relief valve that fits into the Sun T-8A cavity. It can be used as a pilot valve on it's own or together with many types of main stage pressure control valves that have the T-8A cavity in the end of the cartridge.

Page 14: The **RP*C-8** is a normally closed spool type modulating valve, with a T-8A cavity in the end. This would enable any of the Sun pilot valves, such as the RBAP proportional valve, to be fitted into the end to make a high capacity proportional relief valve.

Page 15: The **RP*S-8** is a seated style normally closed modulating valve, with a T-8A cavity in the end. This would enable any of the Sun pilot valves, such as the RBAP proportional valve, to be fitted into the end to make a proportional relief valve with low leakage on the main stage.

Page 18: The **RV*S** is a ventable, seated style, pilot operated relief valve. This provides reduced leakage, faster response and a reduced pressure overshoot to give improved pressure control.

Page 20: The **RV*D-8** is a normally closed, balanced piston, modulating element with a T-8A cavity in the end. The cartridge is ventable and also has an external drain connection. This would enable any Sun pilot valve, such as the RBAP proportional valve, to be fitted into the end to make a ventable proportional relief with separate drain port.

Sequence Cartridge Valves

Page 23: The **RSDC-8** is a normally closed, balanced piston, modulating element with a T-8A cavity in the end and external drain. This would enable any Sun pilot valve such as the RBAP proportional valve to be fitted into the end to make a relief valve with separate pilot drain.

Reducing/Relieving Cartridge Valves

Page 37: The **PB*B-8** is a normally open modulating element with a T-8A cavity in the end. This would enable any Sun pilot valve such as the RBAP proportional valve to be fitted to make a proportional pressure reducing valve.

Page 38: The **PP*B-8** is a normally open modulating element with a T-8A cavity in the end. This would enable any Sun pilot such as the RBAP proportional valve to be fitted into the end to make a proportional pressure reducing/relieving valve.

Page 39: The **PV*A-8** is a normally open modulating element with a T-8A cavity in the end and an external drain. This would enable any Sun pilot valve, such as the RBAP proportional valve, to be fitted into the end to make a proportional pressure reducing/relieving valve with external drain.

Page 40 and 41: The **PRD*** is an electro-proportional, direct acting, pressure reducing/relieving valve available in series 1 only. There are two versions available, one with low leakage and the other with higher leakage and improved response.

Flow Control Cartridge Valves

Page 73: The **FPCC** is an electro-proportional, normally closed throttle valve available in series 1 only. It provides some pressure compensation but needs a separate compensator for more accurate control.

Page 74: The **FPCH** is an electro-proportional, normally open throttle valve available in series 1 only. It provides some pressure compensation but needs a separate compensator for more accurate control.

Priority Flow Control Cartridge Valves

Page 78: The **FV*A-8** is a ventable, fixed orifice, priority flow control valve with a T-8A cavity in the end of the cartridge. This enables a Sun pilot solenoid, pneumatic or manual valve to be fitted into the cartridge to select the priority flow condition or bypass all flow to tank.

Logic Elements

Page 89: The **LO**-8** is a poppet type, spring biased closed, pilot-to-close unbalanced logic valve with a T-8A cavity in the end of the cartridge. This enables a Sun pilot solenoid, pneumatic or manual valve to be fitted into the cartridge to select the valve in the open or closed condition.

Page 95: The **DO*R-8** is a poppet type, pilot-to-close, normally open balanced logic valve with a T-8A cavity in the end of the cartridge. This enables a Sun pilot solenoid, pneumatic or manual valve to be fitted into the cartridge to select the valve in the open or closed condition.

Page 100: The **DK*R-8** is a poppet type, pilot-to-open, normally closed balanced logic valve with a T-8A cavity in the end of the cartridge. This enables a Sun pilot solenoid, pneumatic or manual valve to be fitted into the cartridge to select the valve in the open or closed condition.

Over 40 New Products in this Catalogue

Directional Cartridge Valves

Page 105: The **DRBO** is direct acting, externally drained, normally closed, three-way directional valve in series 1 only. It is available with an adjustment on the pressure at which the valve will switch.

Page 105: The **DRBP** is direct acting, externally drained, normally open, three-way directional valve in series 1 only. The valve is available with an adjustment on the pressure at which the valve will switch.

Page 105: The **DRBR** is a direct acting, internally drained, externally piloted, three-way directional valve in series 1 only. The valve is available with an adjustment on the pressure at which the valve will switch.

Page 106: The **DV*A-8** is a direct acting, normally open, two-way directional valve with a T-8A cavity in the end. This enables a Sun pilot solenoid, pneumatic or manual valve to be fitted into the cartridge to select the valve in the open or closed condition.

Page 106: The **DV*B-8** is a direct acting, normally closed, two-way directional valve with a T-8A cavity in the end. This enables a Sun pilot solenoid, pneumatic or manual valve to be fitted into the cartridge to select the valve in the open or closed condition.

Page 106: The **DV*C-8** is a direct acting, three-way directional valve with Port 1 blocked and a T-8A cavity in the end. This enables a Sun pilot solenoid, pneumatic or manual valve to be fitted into the cartridge to select the valve in the open or closed condition.

Page 106: The **DV*D-8** is a direct acting, three-way directional valve with Port 1 open and a T-8A cavity in the end. This enables a Sun pilot solenoid, pneumatic or manual valve to be fitted into the cartridge to select the valve in the open or closed condition.

Page 107: The **DV*M-8** is a vent-to-operate two-position two-way, normally open directional valve with a T-8A cavity in the end and external drain. This enables a Sun pilot solenoid, pneumatic or manual valve to be fitted into the cartridge to select the valve in the open or closed condition.

Page 107: The **DV*N-8** is a vent-to-operate two-position two-way, normally closed directional valve with a T-8A cavity in the end and external drain. This enables a Sun pilot solenoid, pneumatic or manual valve to be fitted into the cartridge to select the valve in the open or closed condition.

Page 107: The **DV*O-8** is a vent-to-operate two-position three-way directional valve with a T-8A cavity in the end and external drain. This enables a Sun pilot solenoid, pneumatic or manual valve to be fitted into the cartridge to select the valve in the open or closed condition.

Page 107: The **DV*P-8** is a vent-to-operate two-position three-way directional valve with a T-8A cavity in the end and external drain. This enables a Sun pilot solenoid,

pneumatic or manual valve to be fitted into the cartridge to select the valve in the open or closed condition.

Page 108: The **DF*A-8** two-position, two-way normally closed port 1 to 2, directional valve with a T-8A cavity in the end of the cartridge. This enables a Sun pilot solenoid, pneumatic or manual valve to be fitted into the cartridge to select the valve in the open or closed condition.

Page 109: The **DF*B-8** two-position, two-way normally closed port 2 to 1, directional valve with a T-8A cavity in the end of the cartridge. This enables a Sun pilot solenoid, pneumatic or manual valve to be fitted into the cartridge to select the valve in the open or closed condition.

Pilot Control Cartridge Valves

Page 125: The **DAAM** is a manually operated, two-position, two-way pilot valve. This valve could be fitted into any cartridge with a T-8A cavity in the end to provide manual switching. Available with momentary, detented, or dual operator.

Page 129: The **DBAM** is a manually operated, two-position, three-way valve.

Circuit Savers

Page 146: The **COFO** is a 120:1 ratio, pilot to close check valve in series 2 only. This valve is specifically designed for accumulator unloading and dump circuits when the pump is not operating.

Page 152: The **DS*X** is a two-position, three-way, vent-to-shift, normally closed diverter valve. This valve could be used in parallel with flow divider valves to enable the function to be bypassed in traction drive circuits.

Page 153: The **DS*Y** is a two-position, three-way, vent-to-shift diverter valve. This valve works as a simple flow diverter valve.

Page 154: The **LHDT** is a bi-directional, normally open modulating valve in series 1 only. This valve can be used with an external orifice to provide pressure compensated flow control in both directions.

Hybrid Relief Cartridge Valves

Page 156: The **HRDA** is a dual function cartridge providing both a direct acting relief valve and check valve. The relief function is before the check valve.

Page 157: The **HRDB** is a dual function cartridge providing both a direct acting relief valve and check valve. The relief function is after the check valve.

Page 158: The **HVCA** is a dual function cartridge providing both a ventable pilot operated relief and check valve. The ventable relief function is before the check valve.

Page 159: The **HVCA-8** is a dual function cartridge providing both a normally closed modulating function and a check valve and a T-8A cavity in the end of the cartridge. This would enable a Sun pilot valve such as a pilot proportional valve to provide a proportional pressure control and check function in one cartridge.

Contents

<i>Relief Cartridge Valves</i>	5	<i>Solenoid Operated Cartridge Valves</i>	113
<i>Sequence Cartridge Valves</i>	21	<i>Pilot Control Cartridge Valves</i>	121
<i>Reducing and Reducing/Relieving Cartridge Valves</i>	29	<i>Shuttle Cartridge Valves</i>	135
<i>Pilot Operated Check Cartridge Valves</i>	43	<i>Circuit Savers</i>	143
<i>Counterbalance Cartridge Valves</i>	47	<i>Hybrid Relief Cartridge Valves</i>	155
<i>Check Cartridge Valves</i>	59	<i>General Information</i>	161
<i>Flow Control Cartridge Valves</i>	65	Cartridge Control Options	162
<i>Priority Flow Control Cartridge Valves</i>	75	Cartridge Control Kits	163
<i>Flow Divider/Combiner Cartridge Valves</i>	81	Cavity Plugs	165
<i>Logic Elements</i>	87	Solenoid Electrical Connector Options	167
<i>Directional Cartridge Valves</i>	101	Orifice Pressure Drop Data	168
		Model Code Index	169
		<i>Warranty</i>	176

Model Codes printed in Red are Preferred Versions of products shown in this catalogue and most readily available.

Specifications, descriptions and illustrative material contained herein were accurate as known at the time this publication was approved for printing.

Sun Hydraulics reserves the right to discontinue models at any time, or change prices, specifications or designs without notice or incurring obligation.

All rights reserved. This book, or any part thereof, may not be reproduced or transmitted in any form or by any means, electronic or mechanical, including photocopying, recording, or information storage and retrieval systems, for any purpose without the express written permission of Sun Hydraulics Corporation, 1500 West University Parkway, Sarasota, Florida, 34243, USA.

Copyright © 2004 Sun Hydraulics Corporation
Sarasota, FL 34243 USA

Printed in England

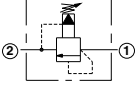
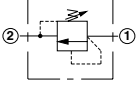
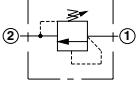
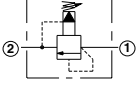
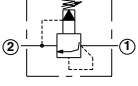
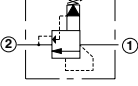
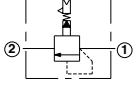
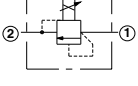
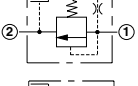
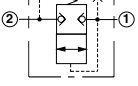
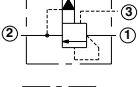
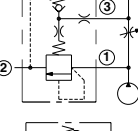
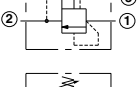
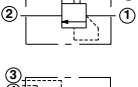
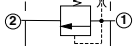

Relief Cartridge Valves

	<i>Cartridge Type</i>	<i>Page</i>
	Pilot Operated, Balanced Piston	6
	Direct Acting	7
	Direct Acting, Pilot Stage	8
	Pilot Operated, Balanced Poppet	9
	Pilot Operated, Balanced Poppet, Soft Start	10
	Pilot Operated, Kick-down	11
	Pilot Operated, Balanced Piston, Air Controlled	12
	Electro-proportional Pilot	13
	Balanced Piston, Modulating Element with Integral Pilot Control Cavity	14
	Balanced Poppet, Modulating Element with Integral Pilot Control Cavity	15
	Ventable, Pilot Operated, Balanced Piston	16
	Modulating Element with Relief Function	17
	Ventable, Pilot Operated, Balanced Poppet	18
	Ventable, Pilot Operated, Balanced Piston with External Drain	19
	Ventable, Balanced Piston, Modulating Element with External Drain and Integral Pilot Control Element	20

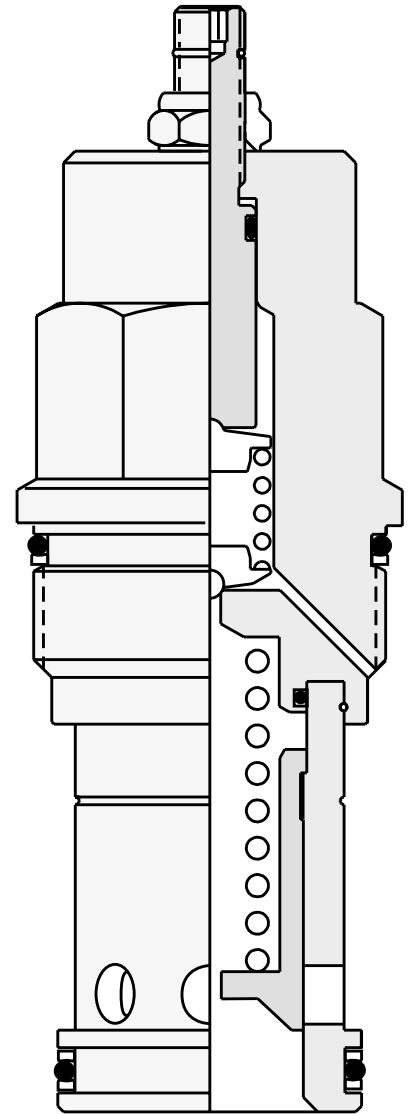

PILOT OPERATED BALANCED PISTON,

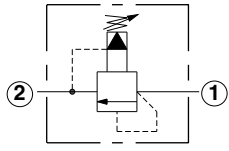
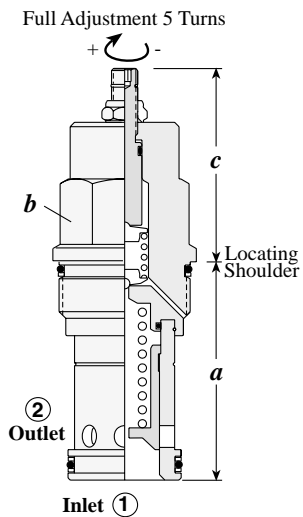

Capacity	Typical Cartridge Model Code	Cavity	Cartridge Dimensions					Installation Torque (Nm)
			a	b	c			
					L	C	K	
45 L/min.	RPCC – LAN	T - 162A	31	19,1	54	56	59	35/40
95 L/min.	RPEC – LAN	T - 10A	39,7	22,2	51	53	58	40/50
200 L/min.	RPGC – LAN	T - 3A	47,8	28,6	54	56	61	60/70
380 L/min.	RPIC – LAN	T - 16A	61,9	31,8	62	64	69	200/215
760 L/min.	RPKC – LAN	T - 18A	79,4	41,3	72	74	78	465/500

Performance Curves

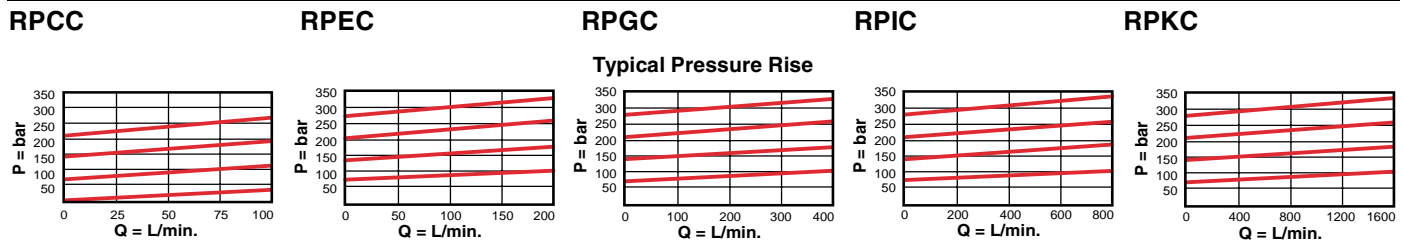

- Maximum operating pressure = 350 bar
- Will accept maximum pressure at Port 2
- Back pressure on the tank port (port 2) is directly additive at a 1:1 ratio to the valve setting
- Factory pressure settings established at 15 L/min.
- Typical response time 10 ms.
- Maximum leakage = RPCC, RPEC: 32,8 cc/min./70 bar, RPGC: 49,2 cc/min./70 bar, RPIC: 66,5 cc/min./70 bar, RPKC: 81,9 cc/min./70 bar
- RPCC minimum setting for all spring ranges is 5 bar.

RP * C - * * *

Nominal Capacity	Control**	Adjustment Range	Seal
C 45 L/min.*	L Standard Screw	A 7 - 210 bar	N Buna-N
E 95 L/min.	C Tamper Resistant	B 3,5 - 105 bar	V Viton
G 200 L/min.	K Handknob	C 10 - 420 bar	
I 380 L/min.		N 4 - 55 bar	
K 760 L/min.		Q 4 - 25 bar	
		W 10 - 315 bar	

Adjustment Range Options:
 A, B, C, and W are standard set at 70 bar.
 N Option is standard set at 25 bar.
 Q Option is standard set at 14 bar.
 * Minimum setting 5 bar on all ranges.
Customer may specify pressure setting.

** See page 162 for information on Control Options

Visit www.sunhydraulics.com for detailed and complete technical information on our full line of products.

DIRECT ACTING

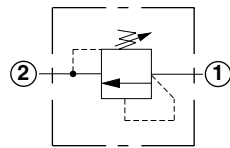
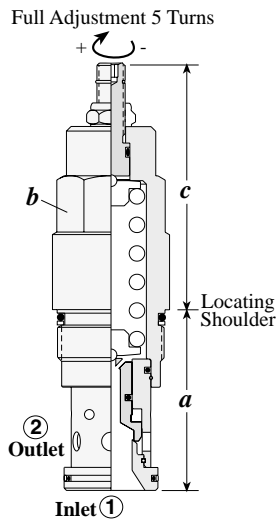

Capacity	Typical Cartridge Model Code	Cavity	Cartridge Dimensions				Installation Torque (Nm)
			a	b	L	C	
45 L/min.	RD BA – LAN	T - 162A	31	19,1	54	56	35/40
95 L/min.	RD DA – LAN	T - 10A	39,7	22,2	61	63	40/50
200 L/min.	RD FA – LAN	T - 3A	47,8	28,6	64	66	60/70
380 L/min.	RD HA – LAN	T - 16A	61,9	31,8	83	85	200/215
760 L/min.	RD JA – LAN	T - 18A	79,4	41,3	100	104	465/500

Performance Curves

RD

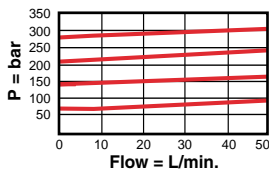

RD

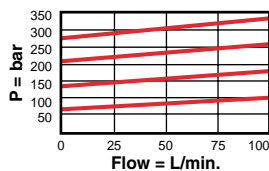

RD

Typical Pressure Rise

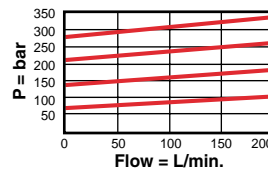

RD

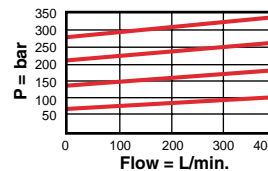

RD

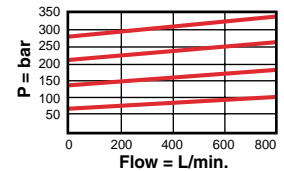

- Maximum operating pressure = 350 bar
- Cannot be adjusted with pressure at Port 1.
- Will accept maximum pressure at Port 2.
- Back pressure on the tank port (port 2) is directly additive at a 1:1 ratio to the valve setting.
- Factory pressure settings established at 15 L/min.
- Typical response time 2 ms.
- Maximum leakage = 0,7 cc/min. at reseal.
- Reseat exceeds 90% of cracking pressure.

RD ★ A - ★ ★ ★

Nominal Capacity	Control**	Adjustment Range	Seal
B 45 L/min.	L Standard Screw	A 35 - 210 bar	N Buna-N
D 95 L/min.	C Tamper Resistant	B 20 - 105 bar	V Viton
F 200 L/min.		C 70 - 420 bar	
H 380 L/min.		D 14 - 55 bar	
J 760 L/min.		E 7 - 25 bar	
		S 3,5 - 14 bar	
		W 70 - 315 bar	

Adjustment Range Options:
 A, B, C, and W are standard set at 70 bar.
 D Option is standard set at 25 bar.
 E Option is standard set at 14 bar.
 S Option is standard set at 7 bar.
Customer may specify pressure setting.

U.S. Patent #4,742,846 ** See page 162 for information on Control Options
 European Patent Pending

Visit www.sunhydraulics.com for detailed and complete technical information on our full line of products.

DIRECT ACTING, PILOT STAGE

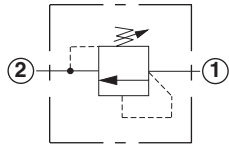
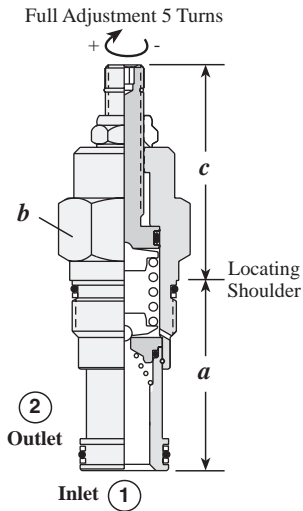

Capacity	Typical Cartridge Model Code	Cavity	Cartridge Dimensions					Installation Torque (Nm)
			a	b	c			
					L	C	K	
1 L/min.	RBAC – LAN	T - 10A	39,7	22,2	51	53	58	40/50
2 L/min.	RBAA – LAN	T - 3A	47,8	28,6	54	56	61	60/70

Performance Curves

RBAC

RBAA

Typical Pressure Rise

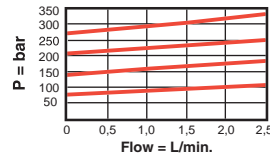
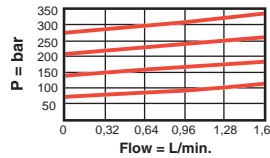

- Maximum operating pressure = 350 bar
- Typical response time 2 ms.
- Maximum leakage less than 0,4 cc/min.
- Back pressure on the tank port (port 2) is directly additive at a 1:1 ratio to the valve setting

RB A ★ – ★ ★ ★

Nominal Capacity	Control**	Adjustment Range	Seal
C 1 L/min.	L Standard Screw	A 2 - 210 bar	N Buna-N
A 2 L/min.	C Tamper Resistant	B 2 - 105 bar	V Viton
	K Handknob	C 2 - 420 bar	
		D 2 - 55 bar	
		E 2 - 25 bar	
		W 2 - 315 bar	

Adjustment Range Options:
 A, B, C, and W are standard set at 70 bar.
 D Option is standard set at 25 bar.
 E Option is standard set at 14 bar.
Customer may specify pressure setting.

** See page 162 for information on Control Options

Visit www.sunhydraulics.com for detailed and complete technical information on our full line of products.

PILOT OPERATED, BALANCED POPPET

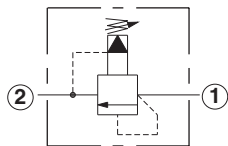
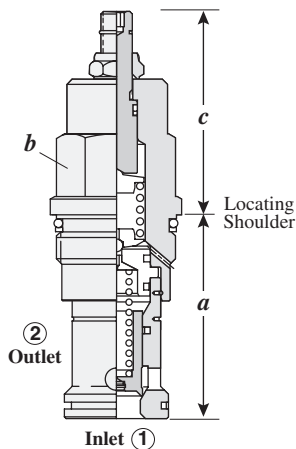

Capacity	Typical Cartridge Model Code	Cavity	Cartridge Dimensions				Installation Torque (Nm)
			a	b	L	C	
200 L/min	RPGS – LAN	T - 3A	47,8	28,6	54	55	60/70
380 L/min.	RPIS – LAN	T - 16A	61,9	31,8	62,0	62,0	200/215

Performance Curves

RPGS

RPIS

Typical Pressure Rise

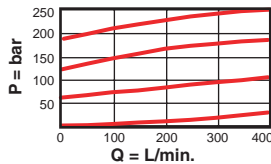
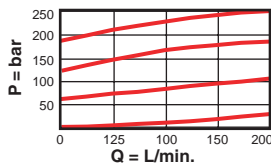

- Maximum operating pressure = 350 bar
- Maximum leakage 0,7 cc/min. at reseal
- Reseat exceeds 90% of cracking pressure.
- Factory pressure settings established at 15 L/min.
- Typical response time 10 ms.
- Back pressure on the tank port (port 2) is directly additive at a 1:1 ratio to the valve setting

RP ★ S – ★ ★ ★

Nominal Capacity	Control**	Adjustment Range	Seal
G 200 L/min.	C Tamper Resistant Factory Set	A 7 - 210 bar	N Buna-N
I 380 L/min.	K Handknob	B 3,5 - 105 bar	V Viton
	L Standard Screw Adjustment	C 10 - 420 bar	
		N 4 - 55 bar	
		Q 4 - 25 bar	
		W 7 - 315 bar	

Adjustment Range Options:
 A, B, C, and W are standard set at 70 bar.
 N Option is standard set at 25 bar.
 Q Option is standard set at 14 bar.
 Customer may specify pressure setting.

** See page 162 for information on Control Options

Visit www.sunhydraulics.com for detailed and complete technical information on our full line of products.

PILOT OPERATED, BALANCED POPPET, SOFT START

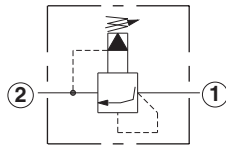
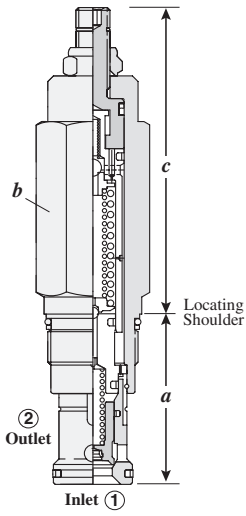

Capacity	Typical Cartridge Model Code	Cavity	Cartridge Dimensions				Installation Torque (Nm)
			a	b	L	C	
200 l/min.	RPGT - LAN	T - 3A	47,8	28,6	85,8	88,1	60/70

Performance Curves

RPGT

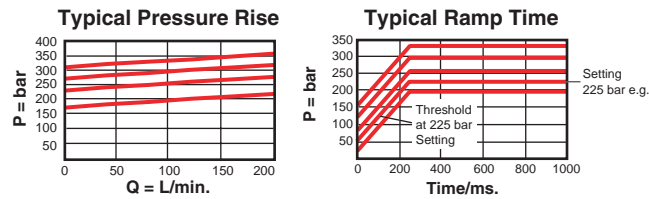

- Maximum operating pressure = 350 bar
- Will accept maximum pressure at Port 2.
- Factory pressure settings established at 15 L/min.
- Shifting time from minimum to maximum setting 250 ms.
- Control pilot flow = 0,16 to 0,41 L/min.

RP G T - * * *

Nominal Capacity	Control**	Adjustment Range	Seal
G 200 L/min.	C Tamper Resistant Factory Set	A 140 - 210 bar	N Buna-N
	L Standard Screw Adjustment	C 315 - 420 bar	V Viton
		W 210-315 bar	

Patents:
U.S. #6,039,070;
Germany EP 1 001 197;
Japan #3,119,230

** See page 162 for information on Control Options

Adjustment Range Options:

A is standard set at 140 bar.
C is standard set at 315 bar.
W is standard set at 210 bar.

Customer may specify pressure setting.

Visit www.sunhydraulics.com for detailed and complete technical information on our full line of products.

PILOT OPERATED, KICK-DOWN

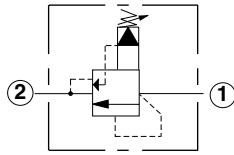
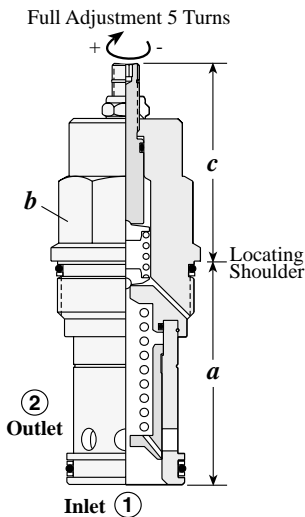

Capacity	Typical Cartridge Model Code	Cavity	Cartridge Dimensions					Installation Torque (Nm)
			a	b	c			
95 L/min.	RQEB – LAN	T - 10A	39,7	22,2	51	53	58	40/50
200 L/min.	RQGB – LAN	T - 3A	47,8	28,6	54	56	61	60/70
380 L/min.	RQIB – LAN	T - 16A	61,9	31,8	62	64	69	200/215
760 L/min.	RQKB – LAN	T - 18A	79,4	41,3	72	74	78	465/500

Performance Curves

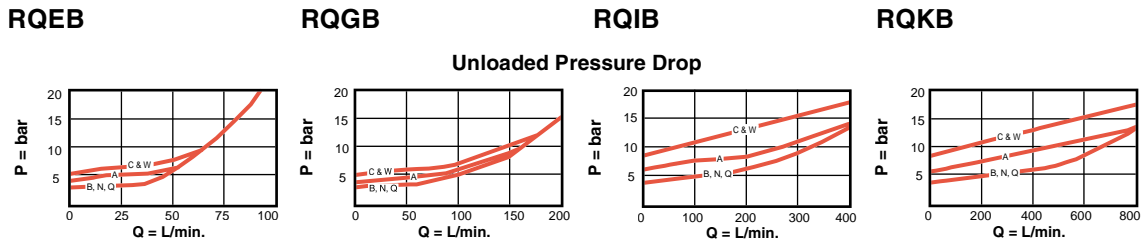

- Maximum operating pressure = 350 bar
- Will accept maximum pressure at Port 2.
- Flow through cartridge must cease to reset valve.
- Back pressure on the tank port (port 2) is directly additive at a 1:1 ratio to the valve setting
- Factory pressure settings established at kick down point.
- Typical response time 25 ms.
- Maximum leakage = RQEB: 32,8 cc/min./70 bar, RQGB: 49,2 cc/min./70 bar, RQIB: 65,5 cc/min./70 bar, RQKB: 81,9 cc/min./70 bar

RQ ★ B – ★ ★ ★

Nominal Capacity	Control**	Adjustment Range	Seal
E 95 L/min.	L Standard Screw	A 7 - 210 bar	N Buna-N
G 200 L/min.	C Tamper Resistant	B 3,5 - 105 bar	V Viton
I 380 L/min.	K Handknob	C 10 - 420 bar	
K 760 L/min.		N 4 - 55 bar	
		Q 4 - 25 bar	
		W 10 - 315 bar	

Adjustment Range Options:
 A, B, C, and W are standard set at 70 bar.
 N Option is standard set at 25 bar.
 Q Option is standard set at 14 bar.
Customer may specify pressure setting.

** See page 162 for information on Control Options

Visit www.sunhydraulics.com for detailed and complete technical information on our full line of products.

PILOT OPERATED, BALANCED PISTON, AIR CONTROLLED

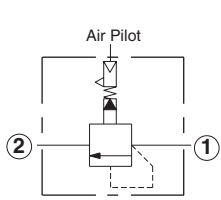
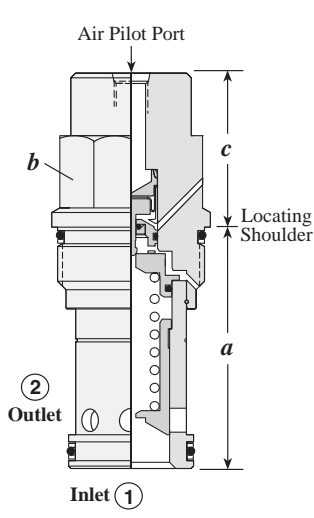

Capacity	Typical Cartridge Model Code	Cavity	Cartridge Dimensions				Installation Torque (Nm)
			a	b	c		
					A	B	
200 L/min.	RPGD – ABN	T - 3A	47,8	28,6	34	-	60/70
380 L/min.	RPID – BBN	T - 16A	61,9	31,8	-	42	200/215
760 L/min.	RPKD – BBN	T - 18A	79.4	41,3	-	51	465/500

Performance Curves

RPGD

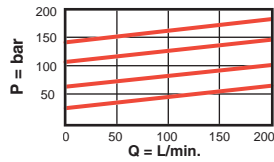

RPID

Typical Pressure Rise

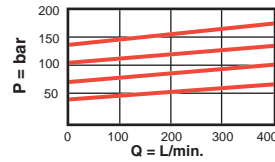

RPKD

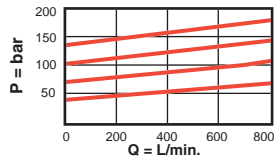

- Maximum operating pressure = 140 bar
- Will accept maximum pressure at Port 2.
- Maximum air pressure should not exceed 10 bar.
- Pilot ratio, air to hydraulic = 1:20
- Typical response time 10 ms.
- Maximum leakage = RPGD: 49,2 cc/min./70 bar, RPID: 65,5 cc/min./70 bar, RPKD: 81,9 cc/min./70 bar.

RP ★ D – ★ ★ ★

Nominal Capacity	Control	Adjustment Range	Seal
G 200 L/min.	Available for RPGD only	B 3,5 - 105 bar	N Buna-N
I 380 L/min.	A 1/4" NPTF Pilot Port at end of Cartridge*	B 3,5 - 105 bar	V Viton
K 760 L/min.			
	Available for RPID, RPKD only		
	B SAE-4 Pilot Port at end of Cartridge*		
	* Maximum air pilot pressure should not exceed 10 bar.		

Visit www.sunhydraulics.com for detailed and complete technical information on our full line of products.

ELECTRO-PROPORTIONAL PILOT

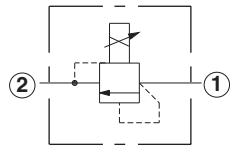
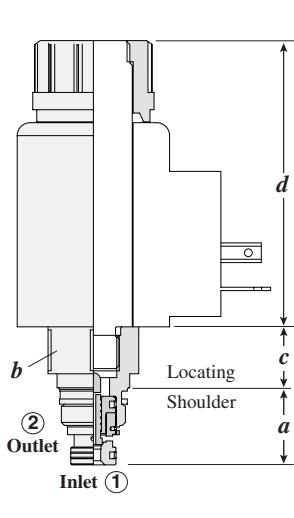

Capacity	Typical Cartridge Model Code	Cavity	Cartridge Dimensions				Installation Torque (Nm)
			a	b	c	d	
1 L/min.	RBAP - MAN	T - 8A	18,8	22,2	15,0	70,1	35/40

Performance Curves

RBAP

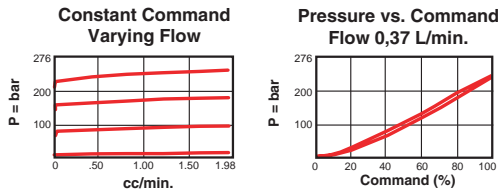

- Maximum operating pressure = 350 bar
- Maximum leakage = 24,6 cc/min at reseal
- Back pressure on the tank port (port 2) is directly additive at a 1:1 ratio to the valve setting
- Reseat exceeds 85% of crack
- Hysteresis with dither <4%
- Hysteresis with DC input <8%
- Linearity with dither <2%
- For optimum performance, an amplifier with current sensing and adjustable dither should be used. Dither should be adjustable between 100 - 250 Hz.

RBAP - ★★

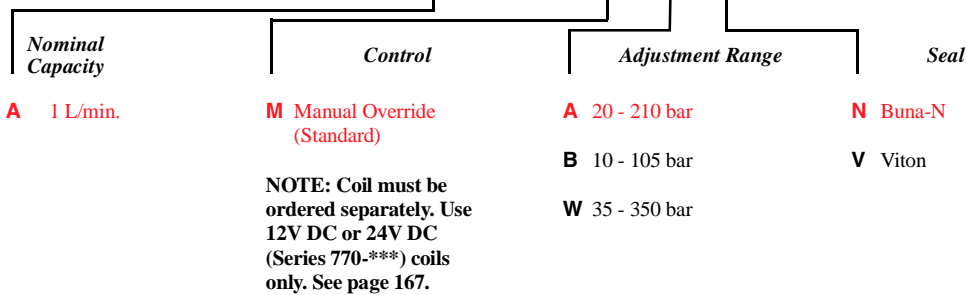

Visit www.sunhydraulics.com for detailed and complete technical information on our full line of products.

BALANCED PISTON, MODULATING ELEMENT WITH INTEGRAL PILOT CONTROL CAVITY

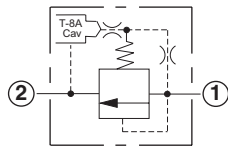
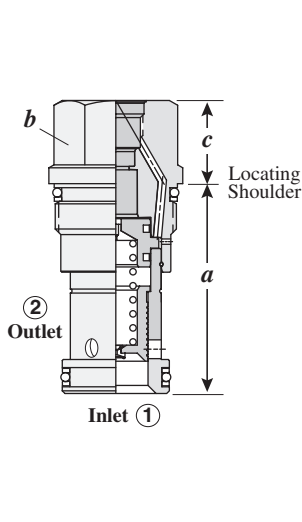

The -8 control option allows a pilot control valve to be incorporated directly into the end of the modulating element via the T-8A cavity. These pilot control cartridges are sold separately and include electro-proportional, solenoid, air pilot, and hydraulic pilot operation. See Pilot Control Cartridges on page 121.

Capacity	Typical Cartridge Model Code	Cavity	Cartridge Dimensions			Installation Torque (Nm)
			a	b	c	
95 L/min.	RPEC - 8WN	T - 10A	39,7	22,2	22,2	40/50
190 L/min.	RPGC - 8WN	T - 3A	47,8	28,6	22,2	60/70
380 L/min.	RPIC - 8WN	T - 16A	61,9	31,8	31,8	200/215
760 L/min.	RPKC - 8WN	T - 18A	79,9	41,3	41,3	465/500

Performance Curves

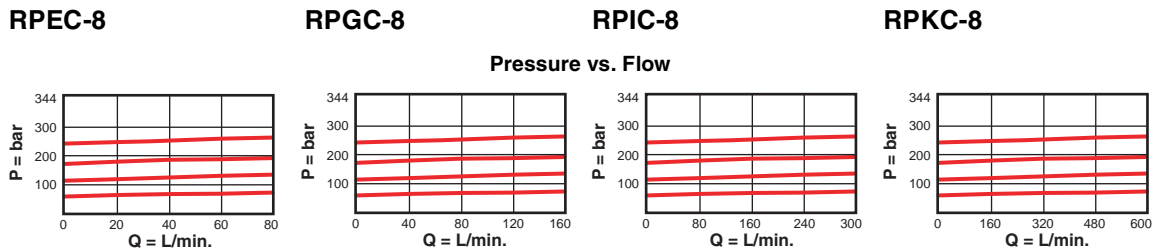

- Maximum operating pressure = 350 bar
- Will accept maximum pressure at Port 2.
- Back pressure on the tank port (port 2) is directly additive at a 1:1 ratio to the valve setting
- Control pilot flow = RPEC-8: 0,11 to 0,16 L/min., RPGC-8: 0,16 to 0,25 L/min., RPIC-8, RPKC-8: 0,25 to 0,33 L/min.
- Maximum leakage = RPEC-8: 32,8 cc/min./70 bar; RPGC-8: 49,2 cc/min./70; RPIC-8: 65,5 cc/min./70 bar; RPKC-8: 81,9 cc/min./70 bar.
- With the -8 control option, the main stage valve should first be installed to the correct torque value. The T-8A pilot control valve should then be installed into the main stage valve to its required torque value.

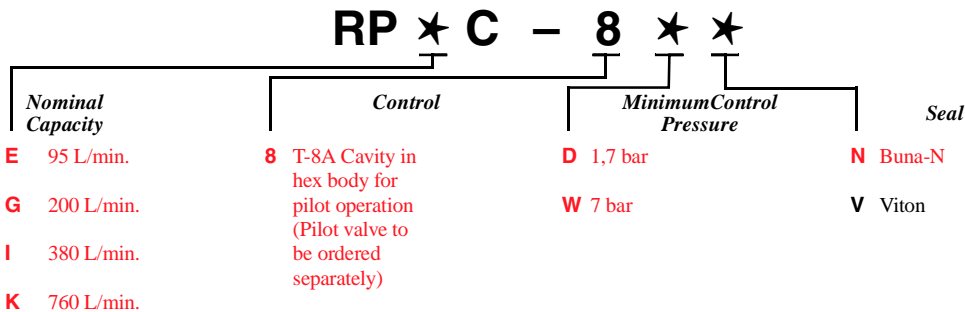

Visit www.sunhydraulics.com for detailed and complete technical information on our full line of products.

BALANCED POPPET, MODULATING ELEMENT WITH INTEGRAL PILOT CONTROL CAVITY

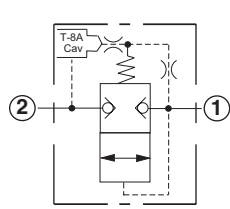
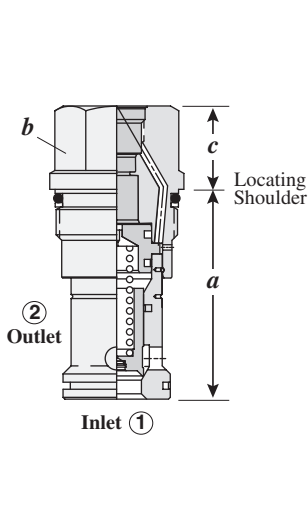

The -8 control option allows a pilot control valve to be incorporated directly into the end of the modulating element via the T-8A cavity. These pilot control cartridges are sold separately and include electro-proportional, solenoid, air pilot, and hydraulic pilot operation. See Pilot Control Cartridges on page 121.

Capacity	Typical Cartridge Model Code	Cavity	Cartridge Dimensions			Installation Torque (Nm)
			a	b	c	
200 L/min.	RPGS - 8WN	T - 3A	84,7	28,6	22,2	60/70
380 L/min.	RPIS - 8WN	T - 16A	84,7	31,8	31,8	200/215

Performance Curves

RPGS-8

RPIS-8

Typical Pressure Rise

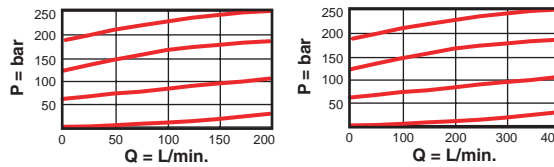

- Maximum operating pressure = 350 bar
- Will accept maximum pressure at Port 2
- Back pressure on the tank port (port 2) is directly additive at a 1:1 ratio to the valve setting.
- Typical response time 10 ms
- Control pilot flow = RPS-8: 0,16 to 0,25 L/min., RPIS-8: 0,25 to 0,33 L/min.
- Maximum leakage = 0,7 cc/min. at reseal
- Reseat exceeds 90% of cracking pressure.
- With the -8 control option, the main stage valve should first be installed to the correct torque value. The T-8A pilot control valve should then be installed into the main stage valve to its required torque value.

RP ★ S - 8 ★ ★

Nominal Capacity	Control**	Minimum Control Pressure	Seal
G 200 L/min.	8 T-8A Cavity in hex body for pilot operation (Pilot valve to be ordered separately)	B 3,5 bar	N Buna-N
I 380 L/min.		W 7 bar	V Viton

Visit www.sunhydraulics.com for detailed and complete technical information on our full line of products.

VENTABLE, PILOT OPERATED, BALANCED PISTON

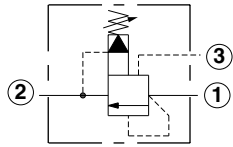
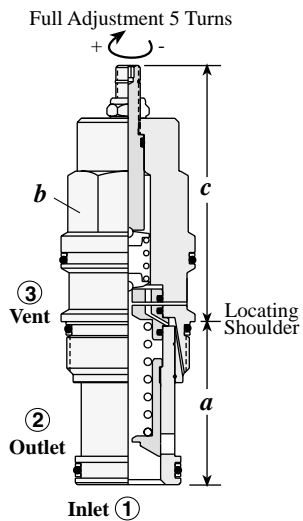

Capacity	Typical Cartridge Model Code	Cavity	Cartridge Dimensions					Installation Torque (Nm)
			a	b	c			
30 L/min.	RVBA – LAN	T - 163A	31	19,1	L	C	K	35/40
60 L/min.	RVCA – LAN	T - 11A	34,9	22,2	64	66	70	40/50
120 L/min.	RVEA – LAN	T - 2A	34,9	28,6	72	74	78	60/70
240 L/min.	RVGA – LAN	T - 17A	46	31,8	84	86	90	200/215
480 L/min.	RVIA – LAN	T - 19A	63,5	41,3	100	104	107	465/500

Performance Curves

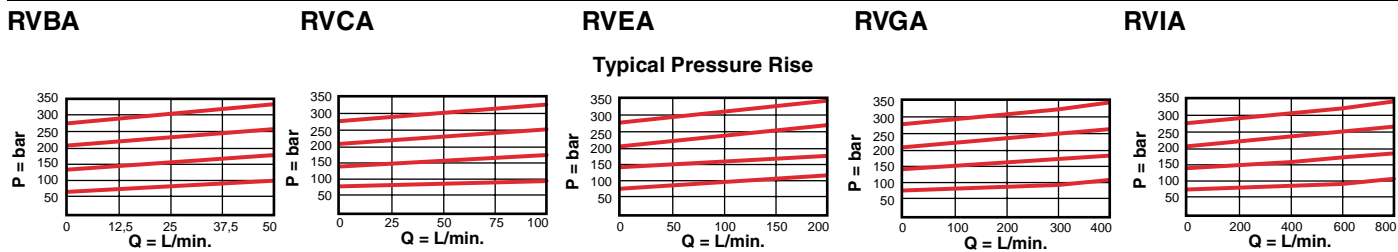

- Maximum operating pressure = 350 bar
- Pressure at port 3 (vent) controls the valve below its setting.
- Back pressure on the tank port (port 2) is directly additive at a 1:1 ratio to the valve setting.
- Control pilot flow = RVBA, RVCA: 0,11 L/min. to 0,16 L/min.; RVEA: 0,16 L/min. to 0,25 L/min.; RVGA, RVIA: 0,25 L/min. to 0,33 L/min.
- Factory pressure setting established at 15 L/min.
- Typical response time 10 ms.
- Maximum leakage = RVBA, RVCA: 32,8 cc/min/70 bar, RVEA: 49,2 cc/min/70 bar, RVGA: 65,5 cc/min/70 bar, RVIA: 81,9 cc/min/70 bar.
- RVBA minimum setting for all spring ranges is 5 bar.
- Will accept maximum pressure at port 2.

RV ★ A – ★ ★ ★

Nominal Capacity	Control**	Adjustment Range	Seal
B 30 L/min.*	L Standard Screw	A 7 - 210 bar	N Buna-N
C 60 L/min.	C Tamper Resistant	B 3,5 - 105 bar	V Viton
E 120 L/min.	K Handknob	C 10 - 420 bar	
G 240 L/min.		N 4 - 55 bar	
I 480 L/min.		Q 4 - 25 bar	
		W 10 - 315 bar	

Adjustment Range Options:
 A, B, C, and W are standard set at 70 bar.
 N Option is standard set at 25 bar.
 Q Option is standard set at 14 bar.
 * Minimum setting 5 bar on all ranges.
Customer may specify pressure setting.

** See page 162 for information on Control Options

Visit www.sunhydraulics.com for detailed and complete technical information on our full line of products.

MODULATING ELEMENT WITH RELIEF FUNCTION

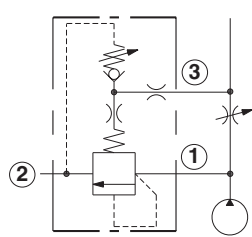
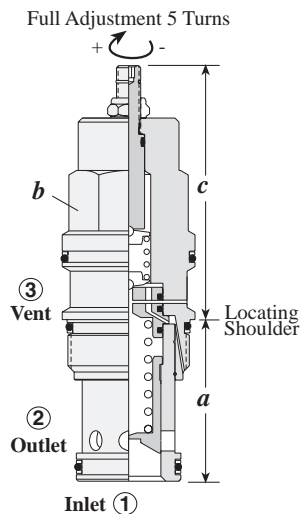

Capacity	Typical Cartridge Model Code	Cavity	Cartridge Dimensions					Installation Torque (Nm)
			a	b	c			
					L	C	K	
10 L/min.	RVBB - LAN	T - 163A	31	19,1	65	67	71	35/40
20 L/min.	RVCB - LAN	T - 11A	34,9	22,2	64	66	70	40/50
40 L/min.	RVEB - LAN	T - 2A	34,9	28,6	72	74	78	60/70
80 L/min.	RVGB - LAN	T - 17A	46	31,8	84	86	90	200/215
160 L/min.	RVIB - LAN	T - 19A	63,5	41,3	100	104	107	465/500

Performance Curves

RVBB

RVCB

RVEB

RVGB

RVIB

Typical Compensator Differentials

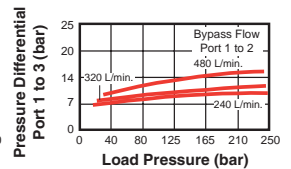
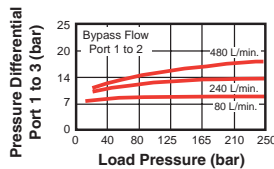
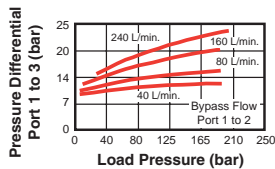
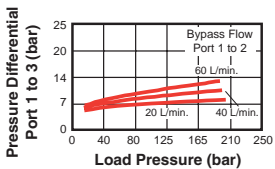
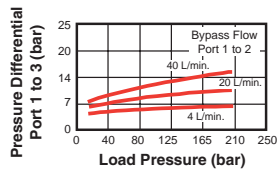

- Back pressure on the tank port (port 2) is directly additive at a 1:1 ratio to the valve setting.
- Maximum operating pressure = 350 bar
- Factory pressure setting established at 15 L/min.
- Typical response time 10 ms.
- Maximum leakage = RVBB, RVCB: 32,8 cc/min/70 bar, RVEB: 49,2 cc/min/70 bar, RVGB: 65,5 cc/min/70 bar, RVIB: 81,9 cc/min/70 bar.

RV ★ B - ★ ★ ★

Nominal Capacity	Control**	Adjustment Range	Seal
B 10 L/min.*	L Standard Screw	A 7 - 210 bar	N Buna-N
C 20 L/min.	C Tamper Resistant	B 7 - 105 bar**	V Viton
E 40 L/min.	K Handknob	C 7 - 420 bar	
G 80 L/min.			
I 160 L/min.			

* For RVCB, the bias pressure is 4 bar.

Adjustment Range Options:

A, B, and C are standard set at 70 bar.

* Minimum setting 7 bar on all ranges.

Customer may specify pressure setting.

** See page 162 for information on Control Options

Visit www.sunhydraulics.com for detailed and complete technical information on our full line of products.

VENTABLE, PILOT OPERATED, BALANCED POPPET

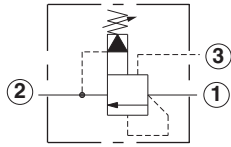
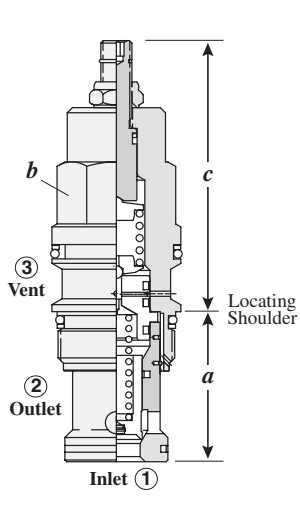

Capacity	Typical Cartridge Model Code	Cavity	Cartridge Dimensions					Installation Torque (Nm)
			a	b	c			
					L	C	K	
120 l/min.	RVES – LAN	T - 2A	35,0	28,6	71,0	73,0	78,0	60/70
200 l/min.	RVGS – LAN	T - 17A	46,0	31,8	83,3	84,1	89,7	200/215

Performance Curves

RVES

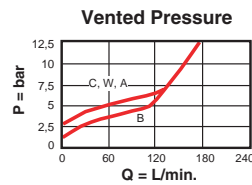
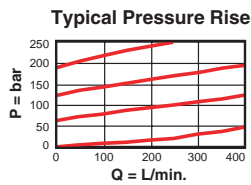

RVGS

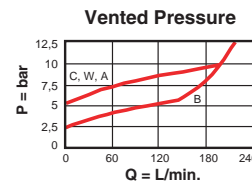
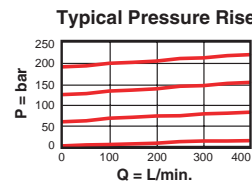

- Maximum operating pressure = 350 bar.
- Will accept maximum pressure at port 2
- Pressure at port 3 (vent) controls the valve below its setting.
- Back pressure on the tank port (port 2) is directly additive at a 1:1 ratio to the valve setting.
- Factory pressure setting established at 15 L/min.
- Maximum leakage at reseal = 0,7 cc/min.
- Reseat exceeds 90% of crack
- Typical response 10 ms
- Control pilot flow = RVES: 0,16 L/min. to 0,25 L/min; RVGS: 0,25 L/min. to 0,33 L/min

RV ★ S – ★ ★ ★

Nominal Capacity	Control**	Adjustment Range	Seal
E 30 L/min.	C Tamper Resistant Factory Set	A 7 - 210 bar	N Buna-N
G 120 L/min.	K Handknob	B 3,5 - 105 bar	V Viton
	L Standard Screw Adjustment	C 10 - 420 bar	
		N 4 - 55 bar	
		Q 4 - 25 bar	
		W 10 - 315 bar	

Adjustment Range Options:
 A, B, C and W are standard set at .70 bar.
 N Option is standard set at 25 bar.
 Q option is standard set at 14 bar.

** See page 162 for information on Control Options

Customer may specify pressure settings.

Visit www.sunhydraulics.com for detailed and complete technical information on our full line of products.

VENTABLE, PILOT OPERATED, BALANCED PISTON WITH EXTERNAL DRAIN

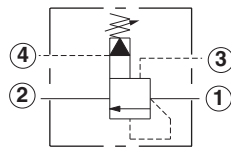
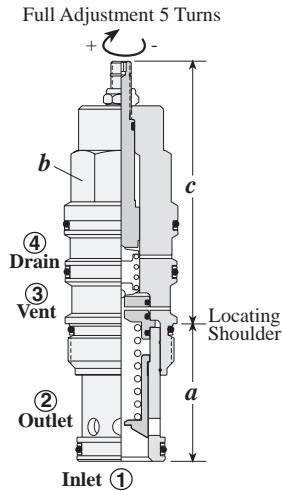

Capacity	Typical Cartridge Model Code	Cavity	Cartridge Dimensions					Installation Torque (Nm)
			a	b	c			
					L	C	K	
60 L/min.	RVCD - LAN	T - 21A	34,9	22,2	79	81	85	40/50
120 L/min.	RVED - LAN	T - 22A	34,9	28,6	88	90	94	60/70
240 L/min.	RVGD - LAN	T - 23A	46	31,8	100	102	107	200/215
480 L/min.	RVID - LAN	T - 24A	63,5	41,3	122	126	129	465/500

Performance Curves

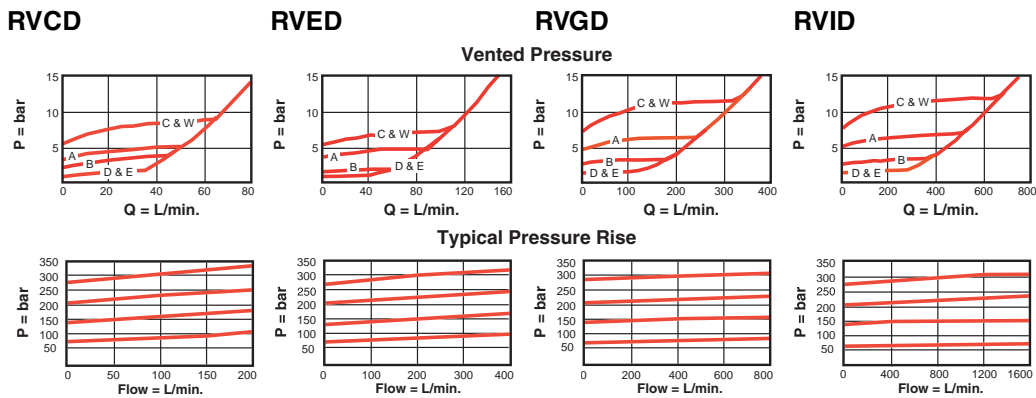

- Maximum operating pressure = 350 bar
- Pressure at port 4 is directly additive to the valve setting at a 1:1 ratio and should not exceed 350 bar
- Pressure at port 3 (vent) controls the valve below its setting.
- Control pilot flow = RVCD: 0,11 L/min. to 0,16 L/min.; RVED: 0,16 L/min. to 0,25 L/min.; RVGD, RVID: 0,25 L/min. to 0,33 L/min.
- Factory pressure setting established at 15 L/min.
- Typical response time 10 ms.
- Maximum leakage = RVCD: 32,8 cc/min/70 bar, RVED: 49,2 cc/min/70 bar, RVGD: 65,5 cc/min/70 bar, RVID: 81,9 cc/min/70 bar.

RV ★ D - ★ ★ ★

Nominal Capacity	Control**	Adjustment Range	Seal
C 60 L/min.	L Standard Screw	A 7 - 210 bar	N Buna-N
E 120 L/min.	C Tamper Resistant	B 3,5 - 105 bar	V Viton
G 240 L/min.	K Handknob	C 10 - 420 bar	
I 480 L/min.		D 2 - 55 bar	
		E 2 - 25 bar	
		W 10 - 315 bar	

Adjustment Range Options:
 A, B, C, and W are standard set at 70 bar.
 D Option is standard set at 25 bar.
 E Option is standard set at 14 bar.
Customer may specify pressure setting.

**See page 162 for information on Control Options

Visit www.sunhydraulics.com for detailed and complete technical information on our full line of products.

VENTABLE, BALANCED PISTON, MODULATING ELEMENT WITH EXTERNAL DRAIN AND INTEGRAL PILOT CONTROL ELEMENT

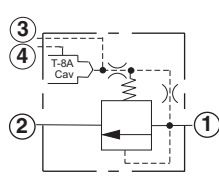
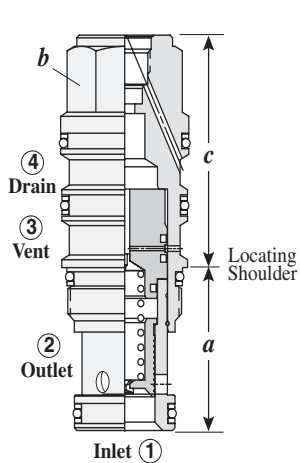

The -8 control option allows a pilot control valve to be incorporated directly into the end of the modulating element via the T-8A cavity. These pilot control cartridges are sold separately and include electro-proportional, solenoid, air pilot, and hydraulic pilot operation. See Pilot Control Cartridges on page 121.

Capacity	Typical Cartridge Model Code	Cavity	Cartridge Dimensions			Installation Torque (Nm)
			a	b	c	
60 L/min.	RVCD - 8WN	T - 21A	34,9	22,2	45,2	45/50
120 L/min.	RVED - 8WN	T - 22A	34,9	28,6	50,8	60/70
240 L/min.	RVGD - 8WN	T - 23A	46,0	31,8	65,8	200/215
480 L/min.	RVID - 8WN	T - 24A	63,5	41,3	80,3	465/500

Performance Curves

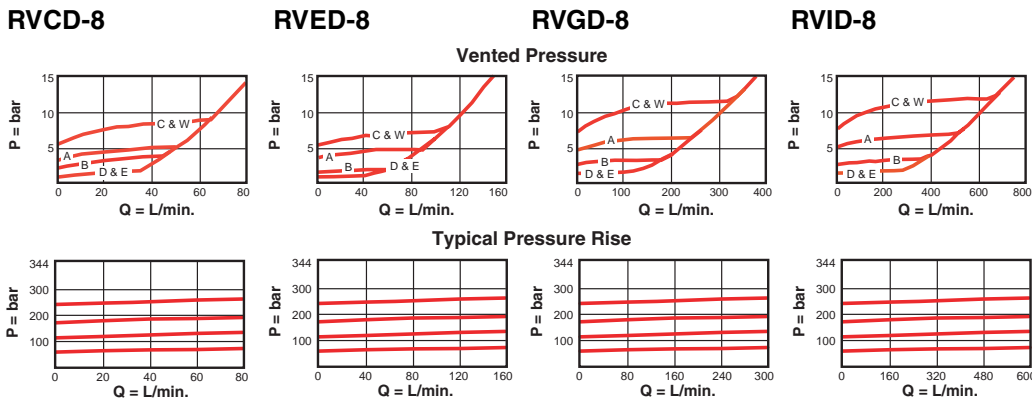

- Maximum operating pressure = 350 bar
- Pressure at port 4 is directly additive to the valve setting at a 1:1 ratio and should not exceed 350 bar
- Pressure at port 3 (vent) controls the valve below its setting.
- Control pilot flow = RVCD: 0,11 L/min. to 0,16 L/min.; RVED: 0,16 L/min. to 0,25 L/min.; RVGD, RVID: 0,25 L/min. to 0,33 L/min.
- Factory pressure setting established at 15 L/min.
- Typical response time 10 ms.
- Maximum leakage = RVCD: 32,8 cc/min/70 bar, RVED: 49,2 cc/min/70 bar, RVGD: 65,5 cc/min/70 bar, RVID: 81,9 cc/min/70 bar

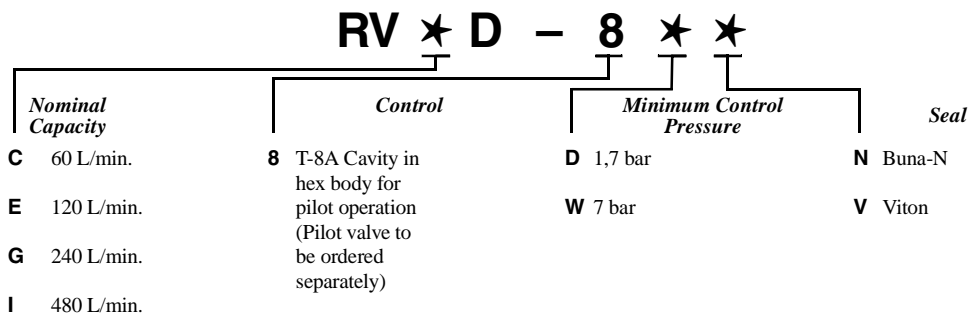

Visit www.sunhydraulics.com for detailed and complete technical information on our full line of products.

Sequence Cartridge Valves

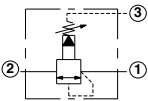
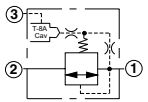
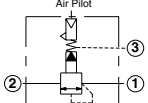
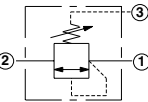
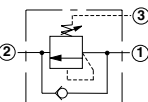
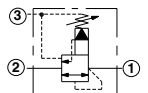
	<i>Cartridge Type</i>	<i>Page</i>
	Pilot Operated, Balanced Piston	22
	Externally Drained, Balanced Piston, Modulating Element	23
	Air Controlled, Pilot Operated, Balanced Piston	24
	Direct Acting without Reverse Flow Check	25
	Direct Acting with Reverse Flow Check	26
	Pilot Operated, Kick-down	27

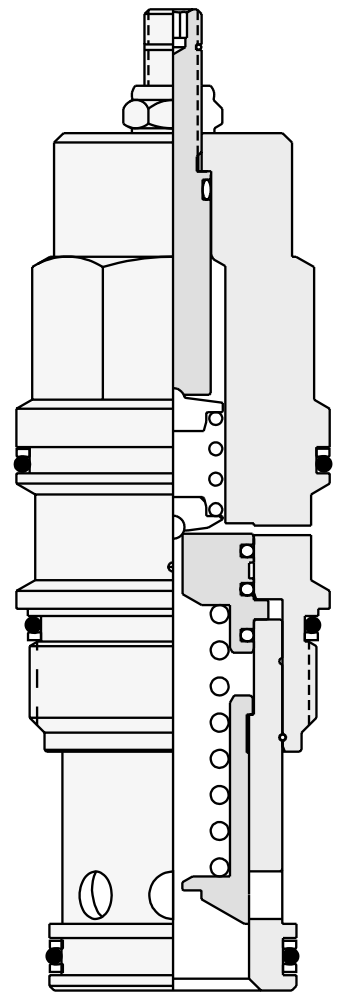

PILOT OPERATED, BALANCED PISTON

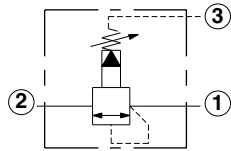
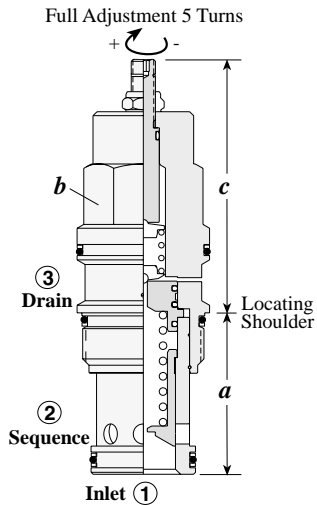

Capacity	Typical Cartridge Model Code	Cavity	Cartridge Dimensions					Installation Torque (Nm)
			a	b	c			
					L	C	K	
30 L/min.	RSBC - LAN	T - 163A	31	19,1	65	67	71	35/40
60 L/min.	RSDC - LAN	T - 11A	34,9	22,2	64	66	70	40/50
120 L/min.	RSFC - LAN	T - 2A	34,9	28,6	72	74	78	60/70
240 L/min.	RSHC - LAN	T - 17A	46	31,8	84	86	90	200/215
480 L/min.	RSJC - LAN	T - 19A	63,5	41,3	100	104	107	465/500

Performance Curves

RSBC RSDC RSFC RSHC RSJC

Pressure Drop Sequenced Open

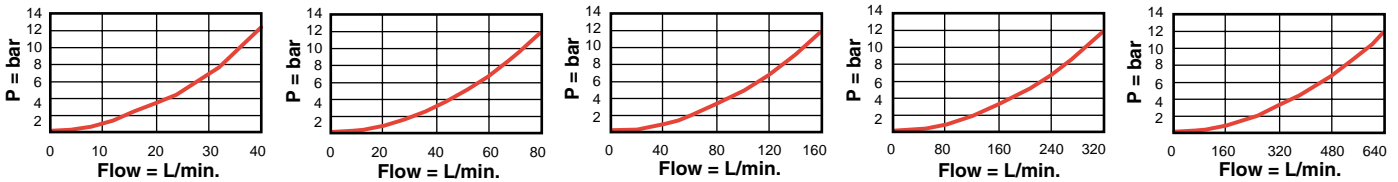

- Maximum operating pressure = 350 bar
- Maximum leakage = RSDC: 32,8 cc/min./70 bar, RSFC: 49,2 cc/min./70 bar, RSHC: 65,5 cc/min./70 bar, RSJC: 81,9 cc/min./70 bar.
- Typical response time 10 ms
- Pressure at port 3 is directly additive to the valve setting at a 1:1 ratio and should not exceed 350 bar.
- Pilot flow continues to increase as the pressure at port 1 (inlet), relative to the pressure at port 3 (drain), rises above the valve setting.
- RSBC minimum setting is 5 bar for all spring ranges.

RS ★ C - ★ ★ ★

Nominal Capacity	Control**	Adjustment Range	Seal
B 30 L/min.*	L Standard Screw	A 7 - 210 bar	N Buna-N
D 60 L/min.	C Tamper Resistant	B 3,5 - 105 bar	V Viton
F 120 L/min.	K Handknob	C 10 - 420 bar	
H 240 L/min.		N 4 - 55 bar	
J 480 L/min.		Q 4 - 25 bar	
		W 10 - 315 bar	

Adjustment Range Options:
 A, B, C, and W are standard set at 70 bar.
 N Option is standard set at 25 bar.
 Q Option is standard set at 14 bar.
 * Minimum setting 5 bar on all ranges.
Customer may specify pressure setting.

** See page 162 for information on Control Options

Visit www.sunhydraulics.com for detailed and complete technical information on our full line of products.

EXTERNALLY DRAINED, BALANCED PISTON, MODULATING ELEMENT

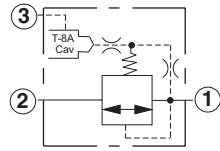
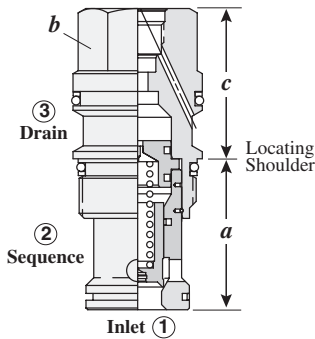

The -8 control option allows a pilot control valve to be incorporated directly into the end of the modulating element via the T-8A cavity. These pilot control cartridges are sold separately and include electro-proportional, solenoid, air pilot, and hydraulic pilot operation. See Pilot Control Cartridges on page 121.

Capacity	Typical Cartridge Model Code	Cavity	Cartridge Dimensions			Installation Torque (Nm)
			a	b	c	
60 L/min.	RSDC - 8WN	T - 11A	34,9	22,2	30,2	40/50
120 L/min.	RSFC - 8WN	T - 2A	34,9	28,6	35,1	60/70
240 L/min.	RSHC - 8WN	T - 17A	46,0	31,8	46,0	200/215
480 L/min.	RSJC - 8WN	T - 19A	63,5	41,3	58,7	465/500

Performance Curves

RSDC-8

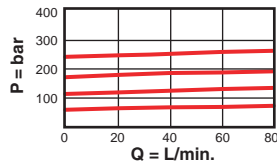

RSFC-8

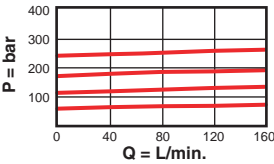

RSHC-8

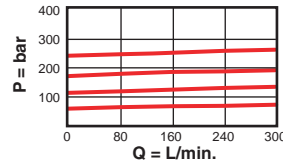

RSJC-8

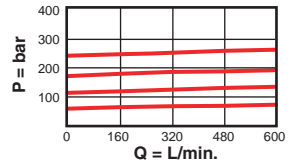

Typical Pressure Rise

- Maximum operating pressure = 350 bar
- Will accept maximum pressure at Port 2.
- Pressure at port 3 is directly additive at a 1:1 ratio to the valve setting and should not exceed 350 bar
- Control pilot flow = RSDC-8: 0,11 to 0,16 L/min., RSFC-8: 0,16 to 0,25 L/min., RSHC-8, RSJC-8: 0,25 to 0,33 L/min.
- Maximum leakage = RSDC-8: 32,8 cc/min./70 bar; RSFC-8: 49,2 cc/min./70 bar; RSHC-8: 65,5 cc/min./70 bar; RSJC-8: 81,9 cc/min./70 bar.
- With the -8 control option, the main stage valve should first be installed to the correct torque value. The T-8A pilot control valve should then be installed into the main stage valve to its required torque value.

RS ★ C - 8 ★ ★

Nominal Capacity	Control	Minimum Control Pressure	Seal
D 60 L/min.	8 T-8A Cavity in hex body for pilot operation (Pilot valve to be ordered separately)	D 1,7 bar	N Buna-N
F 120 L/min.		W 7 bar	V Viton
H 240 L/min.			
J 480 L/min.			

Visit www.sunhydraulics.com for detailed and complete technical information on our full line of products.



AIR CONTROLLED, PILOT OPERATED, BALANCED PISTON

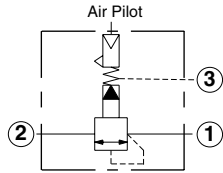
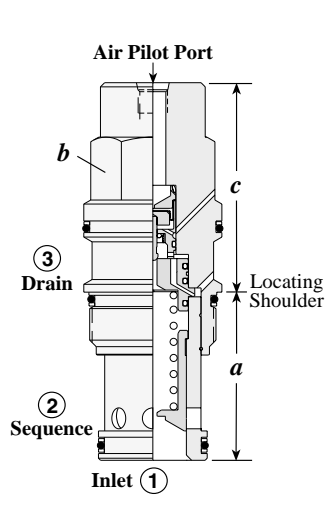

Capacity	Typical Cartridge Model Code	Cavity	Cartridge Dimensions				Installation Torque (Nm)
			a	b	A	B	
120 L/min.	RSFE – ABN	T - 2A	34,9	28,6	51	-	60/70
240 L/min.	RSHE – BBN	T - 17A	46	31,8	-	63	200/215
480 L/min.	RSJE – BBN	T - 19A	63,5	41,3	-	80	465/500

Performance Curves

RSFE

RSHE

RSJE

Pressure Drop Sequenced Open

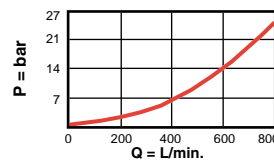
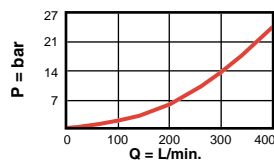
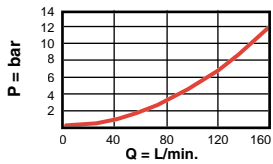

- Pilot ratio, air to hydraulic 1:20
- Maximum operating pressure = 140 bar
- Maximum air pressure should not exceed 10 bar.
- Typical response time 10 ms.
- Maximum leakage = RSFE: 49,2 cc/min./70 bar, RSHE: 65,5 cc/min./70 bar, RSJE: 81,9 cc/min./70 bar.

RS ★ E – ★ B ★

Nominal Capacity	Control	Adjustment Range	Seal
F 120 L/min.	Available for RSFE only	B 3,5 - 105 bar	N Buna-N
H 240 L/min.	A 1/4" NPTF Pilot Port at end of Cartridge*		V Viton
J 480 L/min.			

Available for RSHE, RSJE only

- B** SAE-4
Pilot Port at end of Cartridge*

Visit www.sunhydraulics.com for detailed and complete technical information on our full line of products.

DIRECT ACTING WITHOUT REVERSE FLOW CHECK

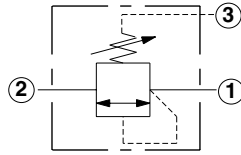
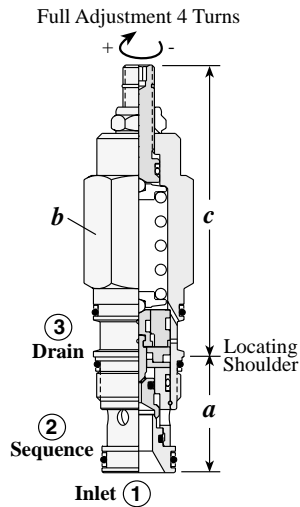

Capacity	Typical Cartridge Model Code	Cavity	Cartridge Dimensions				Installation Torque (Nm)
			a	b	L	C	
60 L/min.	SXCA - LAN	T - 11A	34,9	22,2	79	81	40/50
120 L/min.	SXEA - LAN	T - 2A	34,9	28,6	89	91	60/70

Performance Curves

SXCA

SXEA

Pressure Drop Sequenced Open

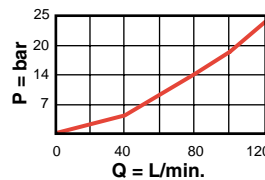
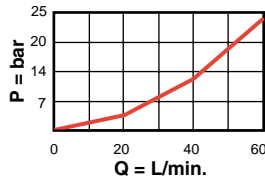

- Maximum operating pressure = 350 bar
- Maximum valve leakage at reseal = 0,7 cc/min
- Typical response time 2 ms
- Pressure at port 3 is directly additive to the valve setting at a 1:1 ratio and should not exceed 350 bar.
- Reseat exceeds 85% of cracking pressure.

SX ★ A - ★ ★ ★

Nominal Capacity	Control**	Adjustment Range	Seal
C 60 L/min.	L Standard Screw	A 35 - 210 bar	N Buna-N
E 120 L/min.	C Tamper Resistant	B 20 - 105 bar	V Viton
		C 140 - 420 bar	
		D 14 - 55 bar	
		W 55 - 315 bar	

Adjustment Range Options:
 A, B, and W are standard set at 70 bar.
 C Option is standard set at 140 bar.
 D Option is standard set at 25 bar.
Customer may specify pressure setting.

** See page 162 for information on Control Options

Visit www.sunhydraulics.com for detailed and complete technical information on our full line of products.

DIRECT ACTING WITH REVERSE FLOW CHECK

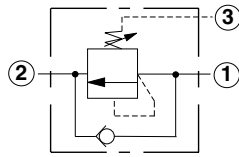
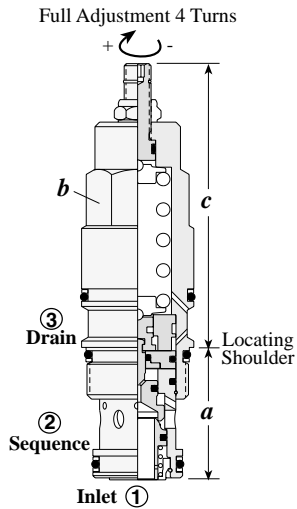

Capacity	Typical Cartridge Model Code	Cavity	Cartridge Dimensions				Installation Torque (Nm)
			a	b	L	C	
60 L/min.	SCCA – LAN	T - 11A	34,9	22,2	79	81	40/50
120 L/min.	SCEA – LAN	T - 2A	34,9	28,6	89	91	60/70
240 L/min.	SCGA – LAN	T - 17A	46	31,8	100	102	200/215
480 L/min.	SCIA – LAN	T - 19A	63,5	41,3	122,9	128,5	465/500

Performance Curves

SCCA

SCEA

SCGA

SCIA

Free Flow to Pressure Drop Sequenced Open

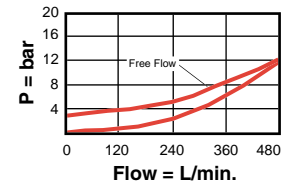
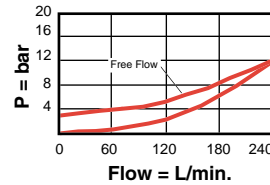
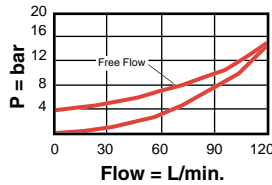
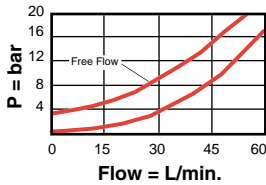

- Maximum operating pressure = 350 bar
- Maximum valve leakage at reseal = 0,7 cc/min
- Free flow check cracking pressure = 2,8 bar
- Typical response time 2 ms
- Pressure at port 3 is directly additive to the valve setting at a 1:1 ratio and should not exceed 350 bar.
- Reseat exceeds 85% of cracking pressure.

SC ★ A - ★ ★ ★

Nominal Capacity	Control**	Adjustment Range	Seal
C 60 L/min.	L Standard Screw	A 35 - 210 bar	N Buna-N
E 120 L/min.	C Tamper Resistant	B 20 - 105 bar	V Viton
G 240 L/min.		C 140 - 420 bar	
I 480 L/min.		D 14 - 55 bar	
		W 55 - 315 bar	

Adjustment Range Options:
 A, B, and W are standard set at 70 bar.
 C Option is standard set at 140 bar.
 D Option is standard set at 25 bar.
Customer may specify pressure setting.

** See page 162 for information on Control Options

Visit www.sunhydraulics.com for detailed and complete technical information on our full line of products.

PILOT OPERATED, KICK-DOWN

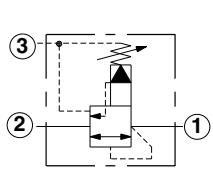
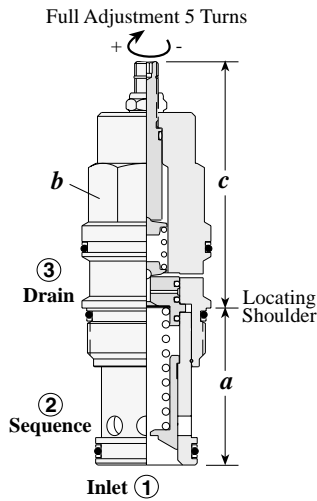

Capacity	Typical Cartridge Model Code	Cavity	Cartridge Dimensions					Installation Torque (Nm)
			a	b	c			
					L	C	K	
60 L/min.	SQDB - LAN	T - 11A	34,9	22,2	64	66	70	40/50
120 L/min.	SQFB - LAN	T - 2A	34,9	28,6	72	74	78	60/70
240 L/min.	SQHB - LAN	T - 17A	46	31,8	84	86	90	200/215
480 L/min.	SQJB - LAN	T - 19A	63,5	41,3	100	104	107	465/500

Performance Curves

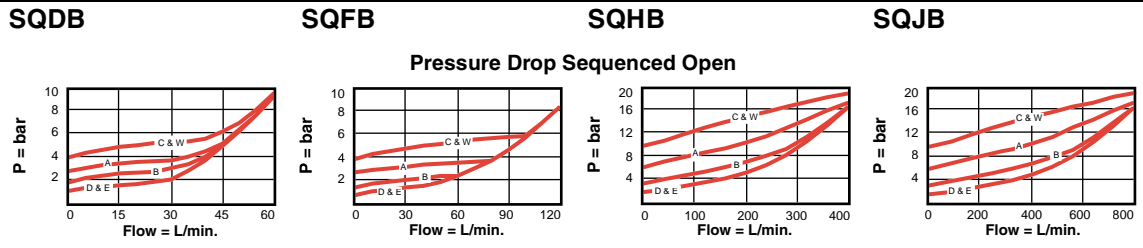

- Maximum operating pressure = 350 bar
- Maximum leakage = SQDB: 32,8 cc/min./70 bar, SQFB: 49,2 cc/min./70 bar, SQHB: 65,5 cc/min./70 bar, SQJB: 81,9 cc/min./70 bar
- Typical response time 25 ms
- Pressure at port 3 is directly additive to the valve setting at a 1:1 ratio and should not exceed 350 bar.
- To reset valve, flow through the cartridge must cease.

SQ * B - * * *

Nominal Capacity	Control**	Adjustment Range	Seal
D 60 L/min.	L Standard Screw	A 7 - 210 bar	N Buna-N
F 120 L/min.	C Tamper Resistant	B 3,5 - 105 bar	V Viton
H 240 L/min.	K Handknob	C 10 - 420 bar	
J 480 L/min.		D 2 - 55 bar	
		E 2 - 25 bar	
		W 10 - 315 bar	

Adjustment Range Options:
 A, B, C, and W are standard set at 70 bar.
 D Option is standard set at 25 bar.
 E Option is standard set at 14 bar.
Customer may specify pressure setting.

** See page 162 for information on Control Options

Visit www.sunhydraulics.com for detailed and complete technical information on our full line of products.

NOTES

Reducing and Reducing/Relieving Cartridge Valves

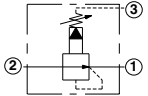
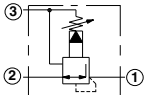
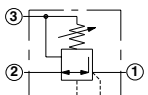
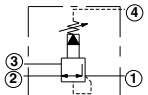
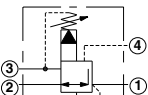
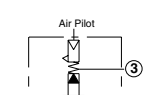
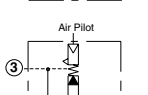
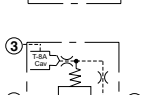
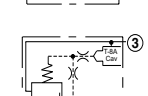
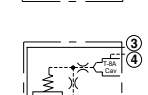
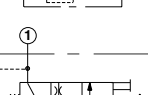
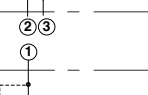
<i>Cartridge Type</i>	<i>Page</i>
	Pilot Operated Reducing 30
	Pilot Operated Reducing/Relieving 31
	Direct Acting Reducing/Relieving 32
	Pilot Operated Reducing/Relieving, Externally Drained 33
	Pilot Operated Reducing/Relieving, Ventable 34
	Air Controlled, Pilot Operated Reducing 35
	Air Controlled, Pilot Operated Reducing/Relieving 36
	Modulating Element with Integral Pilot Control Cavity 37
	3-Way, Modulating Element with Integral Pilot Control Cavity 38
	3-Way, Externally Drained, Modulating Element with Integral Pilot Control Cavity 39
	Electro-proportional, Direct Acting Reducing/Relieving 40
	Electro-proportional, Direct Acting with Low Leakage 41

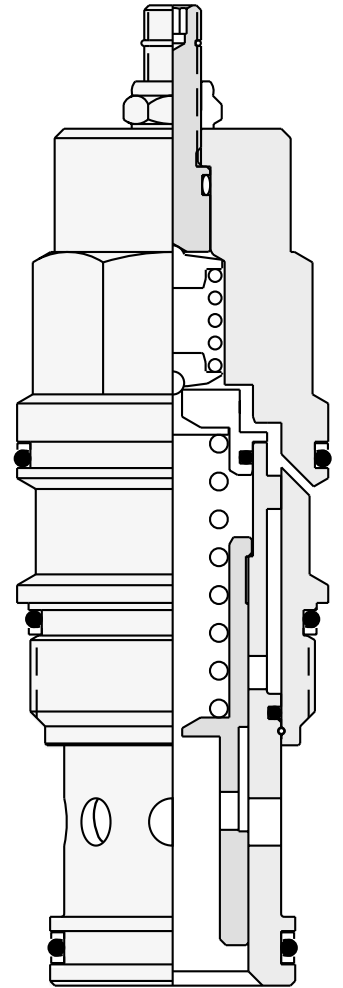

PILOT OPERATED REDUCING

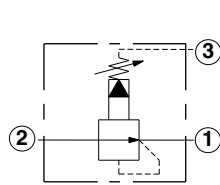
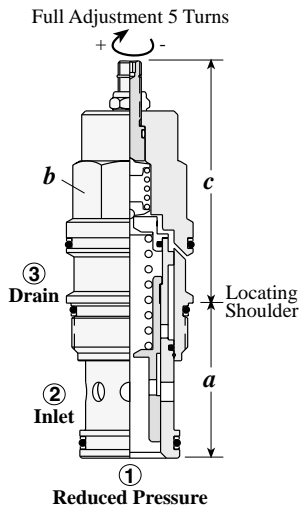

Capacity	Typical Cartridge Model Code	Cavity	Cartridge Dimensions					Installation Torque (Nm)
			a	b	c			
					L	C	K	
20 L/min.	PBBB – LAN	T - 163A	31	19,1	65	67	71	35/40
40 L/min.	PBDB – LAN	T - 11A	34,9	22,2	64	66	70	40/50
80 L/min.	PBFB – LAN	T - 2A	34,9	28,6	72	74	78	60/70
160 L/min.	PBHB – LAN	T - 17A	46	31,8	84	86	90	200/215
320 L/min.	PBJB – LAN	T - 19A	63,5	41,3	100	104	107	465/500

Performance Curves

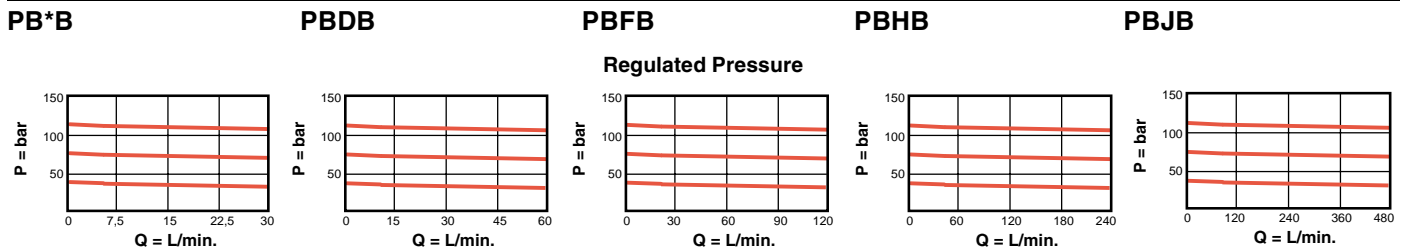

- Maximum operating pressure = 350 bar
- Factory pressure setting established at blocked control port (deadhead)
- Control pilot flow = PBBB, PBDB: 0,11 to 0,16 L/min., PBFB: 0,16 to 0,25 L/min., PBHB, PBJB: 0,25 to 0,33 L/min.
- Pressure at port 3 is directly additive to the valve setting at a 1:1 ratio and should not exceed 210 bar.

PB ★ B – ★ ★ ★

Nominal Capacity	Control**	Adjustment Range	Seal
B 20 L/min.*	L Standard Screw	A 7 - 210 bar	N Buna-N
D 40 L/min.	C Tamper Resistant	B 3,5 - 105 bar	V Viton
F 80 L/min.	K Handknob	N 4 - 55 bar	
H 160 L/min.		Q 4 - 25 bar	
J 320 L/min.		W 10 - 315 bar	

Adjustment Range Options:
 All are standard set at 14 bar.
 Maximum pressure differentials for spring ranges:
 A and B are 210 bar.
 N and Q are 140 bar.
 W is 350 bar inlet pressure.

** See page 162 for information on Control Options

* Minimum setting 5 bar on all ranges.
 Customer may specify pressure setting.

Visit www.sunhydraulics.com for detailed and complete technical information on our full line of products.

PILOT OPERATED REDUCING/RELIEVING

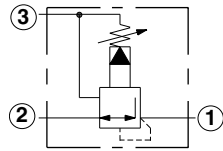
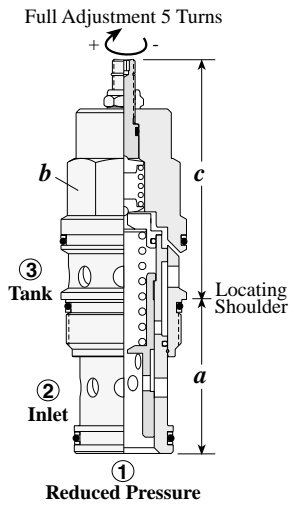

Capacity	Typical Cartridge Model Code	Cavity	Cartridge Dimensions					Installation Torque (Nm)
			a	b	c			
					L	C	K	
40 L/min.	PPDB - LAN	T - 11A	34,9	22,2	64	66	70	40/50
80 L/min.	PPFB - LAN	T - 2A	34,9	28,6	72	74	78	60/70
160 L/min.	PPHB - LAN	T - 17A	46	31,8	84	86	90	200/215
320 L/min.	PPJB - LAN	T - 19A	63,5	41,3	100	104	107	465/500

Performance Curves

PPDB

PPFB

PPHB

PPJB

Regulated Pressure

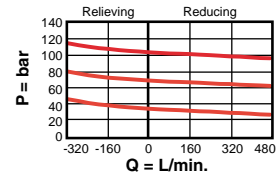
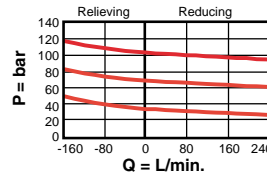
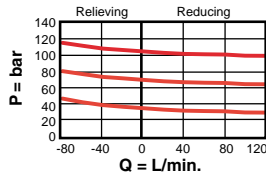
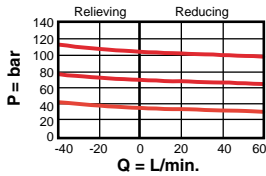

- Maximum operating pressure = 350 bar
- Factory pressure setting established at blocked control port (deadhead)
- Control pilot flow = PPDB: 0,11 to 0,16 L/min., PPFB: 0,16 to 0,25 L/min., PPHB, PPJB: 0,25 to 0,33 L/min.
- Pressure at port 3 is directly additive to the valve setting at a 1:1 ratio and should not exceed 210 bar.

PP * B - * * *

Nominal Capacity	Control**	Adjustment Range	Seal
D 40 L/min.	L Standard Screw	A 7 - 210 bar	N Buna-N
F 80 L/min.	C Tamper Resistant	B 3,5 - 105 bar	V Viton
H 160 L/min.	K Handknob	N 4 - 55 bar	
J 320 L/min.		Q 4 - 25 bar	
		W 10 - 315 bar	

Adjustment Range Options:
 All are standard set at 14 bar.
 Maximum pressure differentials for spring ranges:
 A and B are 210 bar.
 N and Q are 140 bar.
 W is 350 bar inlet pressure.
Customer may specify pressure setting.

** See page 162 for information on Control Options

Visit www.sunhydraulics.com for detailed and complete technical information on our full line of products.

DIRECT ACTING REDUCING/RELIEVING

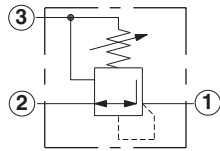
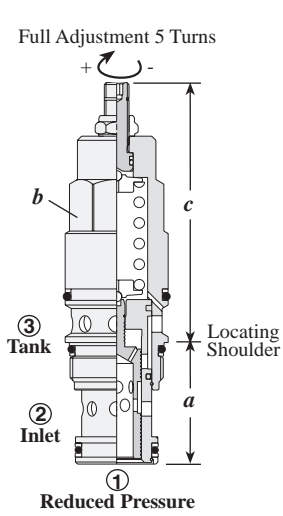

Capacity	Typical Cartridge Model Code	Cavity	Cartridge Dimensions					Installation Torque (Nm)
			a	b	c			
					L	C	K	
40 L/min.	PRDB - LAN	T - 11A	34,9	22,2	79	81	85	40/50
80 L/min.	PRFB - LAN	T - 2A	34,9	28,6	89	91	96	60/70
160 L/min.	PRHB - LAN	T - 17A	46	31,8	100	102	107	200/215
320 L/min.	PRJB - LAN	T - 19A	63,5	41,3	124	127,8	130	350/375

Performance Curves

PRDB

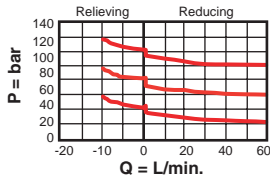

PRFB

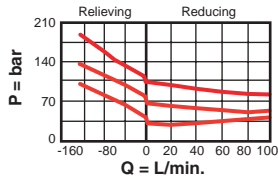

PRHB

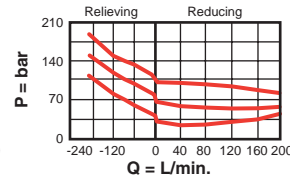

PRJB

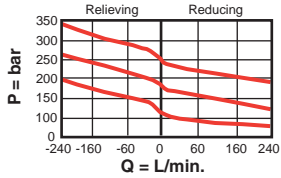

Regulated Pressure

- Maximum operating pressure = 350 bar
- Factory pressure setting established at blocked control port (deadhead)
- Maximum leakage = PRDB: 32,8 cc/min./70 bar; PRFB: 49,2 cc/min./70; PRHB: 65,5 cc/min./70 bar; PRJB: 81,9 cc/min./70 bar.
- Pressure at port 3 is directly additive to the valve setting at a 1:1 ratio and should not exceed 210 bar.
- All spring ranges are capable of operating with 350 bar inlet pressure.

PR ★ B - ★ ★ ★

Nominal Capacity	Control**	Adjustment Range	Seal
D 40 L/min.	L Standard Screw	A 35 - 210 bar	N Buna-N
F 80 L/min.	C Tamper Resistant	B 3,5 - 105 bar	V Viton
H 160 L/min.	K Handknob	D 1,5 - 55 bar	
J 320 L/min.		E 1,5 - 25 bar	
		S 1,5 - 14 bar	
		W*50 - 315 bar	

Available for PRFB and PRHB

- A** 50-210 bar
- B** 20-105 bar
- D** 14-55 bar
- E** 7-25 bar
- S** 3,5-14 bar

Adjustment Range Options:

PRDB Only:

A is standard set at 70 bar.

B, D, E, S are standard set at 14 bar.

PRFB, PRHB:

A, W are standard set at 70 bar.

D is standard set at 25 bar.

E is standard set at 14 bar.

S is standard set at 7 bar.

** See page 162 for information on Control Options

* Not available for PRFB, PRHB

Customer may specify pressure setting.

Visit www.sunhydraulics.com for detailed and complete technical information on our full line of products.

PILOT OPERATED REDUCING/RELIEVING, EXTERNALLY DRAINED

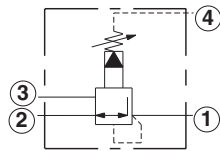
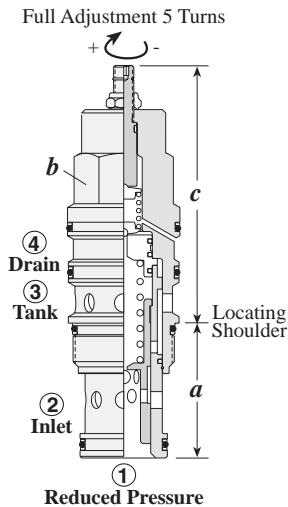

Capacity	Typical Cartridge Model Code	Cavity	Cartridge Dimensions					Installation Torque (Nm)
			a	b	c			
40 L/min.	PVDA – LAN	T - 21A	34,9	22,2	L	C	K	40/50
80 L/min.	PVFA – LAN	T - 22A	34,9	28,6	88	90	94	60/70
160 L/min.	PVHA – LAN	T - 23A	46	31,8	100	102	107	200/215
320 L/min.	PVJA – LAN	T - 24A	63,5	41,3	122	126	129	465/500

Performance Curves

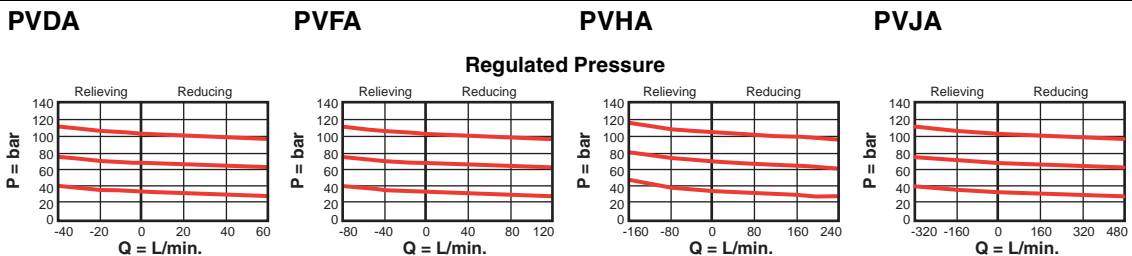

- Maximum operating pressure = 350 bar
- Factory pressure setting established at blocked control port (deadhead)
- Control pilot flow = PVDA: 0,11 to 0,16 L/min., PVFA: 0,16 to 0,25 L/min., PVHA, PVJA: 0,25 to 0,33 L/min.
- Maximum pressure at port 3 should be limited to 210 bar.
- Pressure on the drain (port 4) is directly additive to the valve setting at a 1:1 ratio and should not exceed 350 bar.

PV ★ A – ★ ★ ★

Nominal Capacity	Control**	Adjustment Range	Seal
D 40 L/min.	L Standard Screw	A 7 - 210 bar	N Buna-N
F 80 L/min.	C Tamper Resistant	B 3,5 - 105 bar	V Viton
H 160 L/min.	K Handknob	D 2 - 55 bar	
J 320 L/min.		E 2 - 25 bar	
		W 10 - 315 bar	

Adjustment Range Options:
 All are standard set at 14 bar.
 Maximum pressure differentials for spring ranges:
 A and B are 210 bar.
 D and E are 140 bar.
 W is 350 bar inlet pressure.
 Customer may specify pressure setting.

**See page 162 for information on Control Options

Visit www.sunhydraulics.com for detailed and complete technical information on our full line of products.

PILOT OPERATED REDUCING/RELIEVING, VENTABLE

Full Adjustment 5 Turns

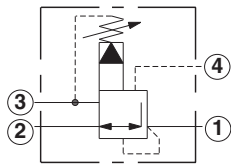
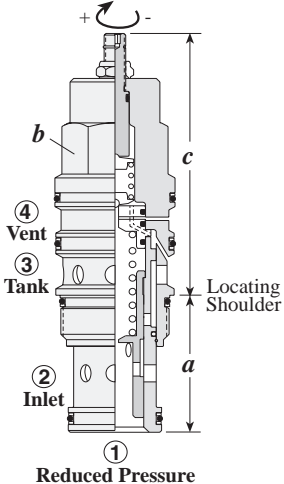

Capacity	Typical Cartridge Model Code	Cavity	Cartridge Dimensions					Installation Torque (Nm)
			a	b	c			
					L	C	K	
40 L/min.	PVDB - LAN	T - 21A	34,9	22,2	79	81	85	40/50
80 L/min.	PVFB - LAN	T - 22A	34,9	28,6	88	90	94	60/70
160 L/min.	PVHB - LAN	T - 23A	46	31,8	100	102	107	200/215
320 L/min.	PVJB - LAN	T - 24A	63,5	41,3	122	126	129	465/500

Performance Curves

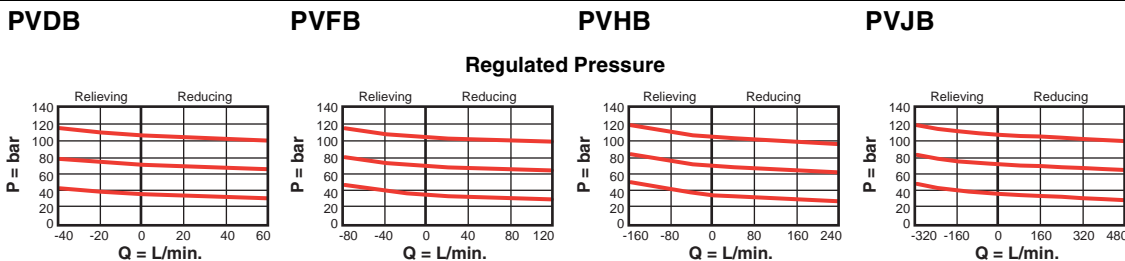

- Maximum operating pressure = 350 bar
- Factory pressure setting established at blocked control port (deadhead)
- Control pilot flow = PVDB: 0,11 to 0,16 L/min., PVFB: 0,16 to 0,25 L/min., PVHB, PVJB: 0,25 to 0,33 L/min.
- Pressure at port 3 is directly additive to the valve setting at a 1:1 ratio and should not exceed 210 bar.
- By controlling the pressure at the vent (port 4), the effective setting of the valve can be controlled below the nominal valve setting.

PV ★ B - ★ ★ ★

Nominal Capacity	Control**	Adjustment Range	Seal
D 40 L/min.	L Standard Screw	A 7 - 210 bar	N Buna-N
F 80 L/min.	C Tamper Resistant	B 3,5 - 105 bar	V Viton
H 160 L/min.	K Handknob	D 2 - 55 bar	
J 320 L/min.		E 2 - 25 bar	
		W 10 - 315 bar	

** See page 162 for information on Control Options

Adjustment Range Options:
 All are standard set at 14 bar.
 Maximum pressure differentials for spring ranges:
 A and B are 210 bar.
 D and E are 140 bar.
 W is 350 bar inlet pressure.
Customer may specify pressure setting.

Visit www.sunhydraulics.com for detailed and complete technical information on our full line of products.

Reducing and Reducing/Relieving Valves

AIR CONTROLLED, PILOT OPERATED REDUCING

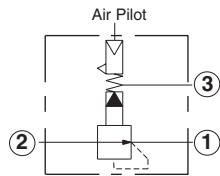
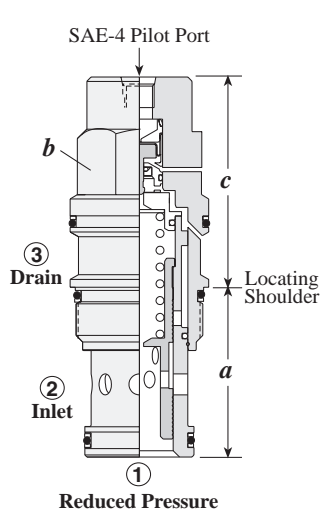

Capacity	Typical Cartridge Model Code	Cavity	Cartridge Dimensions				Installation Torque (Nm)
			a	b	c		
80 L/min.	PBFC – ABN	T - 2A	34,9	28,6	51	-	60/70
160 L/min.	PBHC – BBN	T - 17A	46	31,8	-	63	200/215
320 L/min.	PBJC – BBN	T - 19A	63,5	41,3	-	80	465/500

Performance Curves

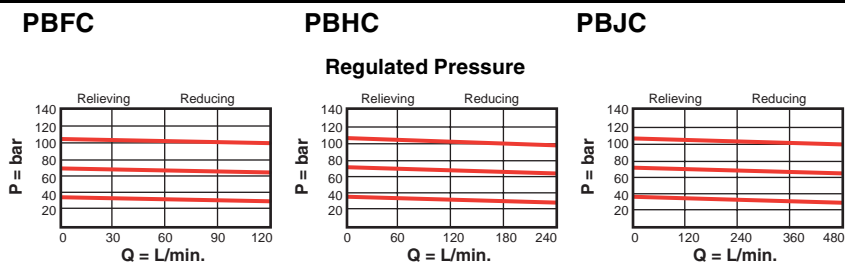

- Pilot ratio, air to hydraulic 1:20
- Maximum operating pressure = 140 bar
- Maximum air pressure should not exceed 10 bar.
- Control pilot flow = PBFC: 0,16 to 0,25 L/min., PBHC, PBJC: 0,25 to 0,33 L/min.
- Maximum pressure differential, inlet to outlet = 210 bar.
- The pressure at port 3 determines the minimum valve setting and should not exceed 70 bar.

PB ★ C – ★ ★ ★

Nominal Capacity	Control	Adjustment Range	Seal
F 80 L/min.	Available in PBFC only	B 3,5 - 105 bar	N Buna-N
H 160 L/min.	A 1/4" NPTF Pilot Port at end of Cartridge		V Viton
J 320 L/min.			

Available for PBHC, PBJC only

B SAE-4 Pilot Port at end of Cartridge

Visit www.sunhydraulics.com for detailed and complete technical information on our full line of products.

Reducing and Reducing/Relieving Valves

AIR CONTROLLED, PILOT OPERATED REDUCING/RELIEVING

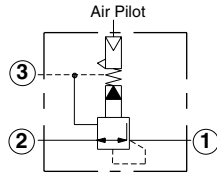
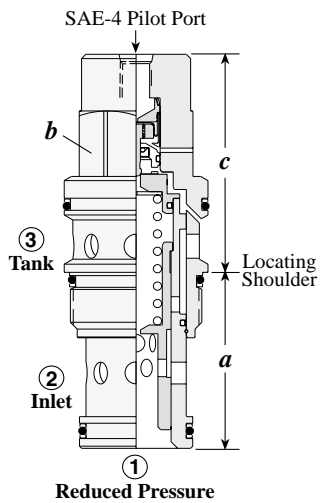

Capacity	Typical Cartridge Model Code	Cavity	Cartridge Dimensions				Installation Torque (Nm)
			a	b	c		
80 L/min.	PPFC – ABN	T - 2A	34,9	28,6	51	-	60/70
160 L/min.	PPHC – BBN	T - 17A	46	31,8	-	63	200/215
320 L/min.	PPJC – BBN	T - 19A	63,5	41,3	-	80	465/500

Performance Curves

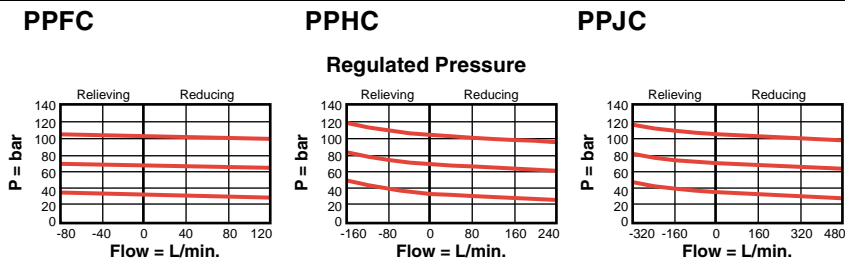

- Pilot ratio, air to hydraulic 1:20 Maximum operating pressure = 140 bar
- Maximum air pressure should not exceed 10 bar.
- Control pilot flow = PPFC: 0,16 to 0,25 L/min., PPHC, PPJC: 0,25 to 0,33 L/min.
- Maximum pressure differential, inlet to outlet = 210 bar.
- The pressure at port 3 determines the minimum valve setting and should not exceed 70 bar.

PP ★ C – ★ ★ ★			
Nominal Capacity	Control	Adjustment Range	Seal
F 80 L/min.	Available in PPFC only	B 3,5 - 105 bar	N Buna-N
H 160 L/min.	A 1/4" NPTF Pilot Port at end of Cartridge	B 3,5 - 105 bar	V Viton
J 320 L/min.			
<i>Available for PPHC, PPJC only</i>			
	B SAE-4 Pilot Port at end of Cartridge		

Visit www.sunhydraulics.com for detailed and complete technical information on our full line of products.

MODULATING ELEMENT WITH INTEGRAL PILOT CONTROL CAVITY

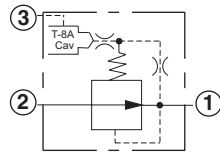
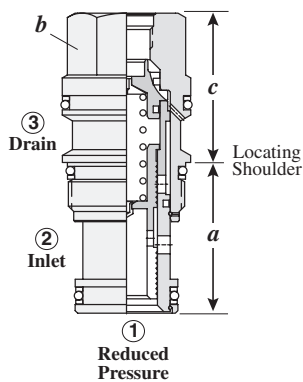

The -8 control option allows a pilot control valve to be incorporated directly into the end of the modulating element via the T-8A cavity. These pilot control cartridges are sold separately and include electro-proportional, solenoid, air pilot, and hydraulic pilot operation. See Pilot Control Cartridges on page 121.

Capacity	Typical Cartridge Model Code	Cavity	Cartridge Dimensions			Installation Torque (Nm)
			a	b	c	
40 L/min.	PBDB – 8WN	T - 11A	34,9	22,2	30,2	40/50
80 L/min.	PBFB – 8WN	T - 2A	34,9	28,6	35,1	60/70
160 L/min.	PBHB – 8WN	T - 17A	46,0	31,8	46,0	200/215
320 L/min.	PBJB – 8WN	T - 19A	63,5	41,3	58,7	465/500

Performance Curves

PBDB-8

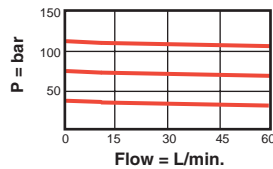

PBFB-8

Regulated Pressure with T-8A Pilot Stage Installed

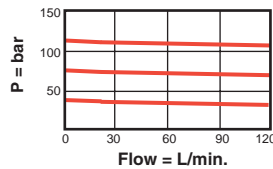

PBHB-8

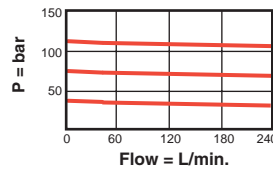

PBJB-8

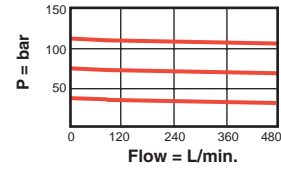

- Maximum operating pressure = 350 bar
- Control pilot flow = PBDB-8: 0,11 to 0,16 L/min., PBFB-8: 0,16 to 0,25 L/min., PBHB-8, PBJB-8: 0,25 to 0,33 L/min.
- Pressure at port 3 is directly additive to the valve setting at a 1:1 ratio and should not exceed 210 bar.
- Maximum inlet pressure is determined by the bias spring. The D spring is limited to 140 bar maximum differential pressure and the W spring is limited to 350 bar maximum inlet pressure.
- With the -8 control option, the main stage valve should first be installed to the correct torque value. The T-8A pilot control valve should then be installed into the main stage valve to its required torque value.

PB * B - 8 * *

Nominal Capacity	Control	Minimum Control Pressure	Seal
D 40 L/min.	8 T-8A Cavity in hex body for pilot operation (Pilot valve to be ordered separately)	D 1,7 bar	N Buna-N
F 80 L/min.		W 7 bar	V Viton
H 160 L/min.			
J 320 L/min.			

Visit www.sunhydraulics.com for detailed and complete technical information on our full line of products.

Reducing and Reducing/Relieving Valves

3-WAY, MODULATING ELEMENT WITH INTEGRAL PILOT CONTROL CAVITY

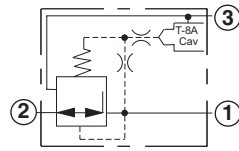
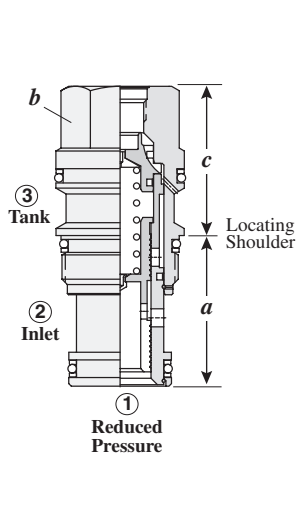

The -8 control option allows a pilot control valve to be incorporated directly into the end of the modulating element via the T-8A cavity. These pilot control cartridges are sold separately and include electro-proportional, solenoid, air pilot, and hydraulic pilot operation. See Pilot Control Cartridges on page 121.

Capacity	Typical Cartridge Model Code	Cavity	Cartridge Dimensions			Installation Torque (Nm)
			a	b	c	
40 L/min.	PPDB - 8WN	T - 11A	34,9	22,2	30,2	40/50
80 L/min.	PPFB - 8WN	T - 2A	34,9	28,6	35,1	60/70
160 L/min.	PPHB - 8WN	T - 17A	46,0	31,8	46,0	200/215
320 L/min.	PPJB - 8WN	T - 19A	63,5	41,3	58,7	465/500

Performance Curves

PPDB-8

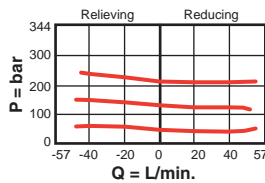

PPFB-8

Regulated Pressure with T-8A Pilot Stage Installed

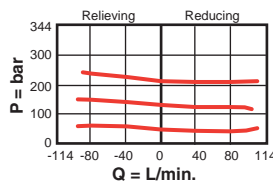

PPHB-8

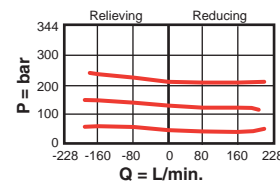

PPJB-8

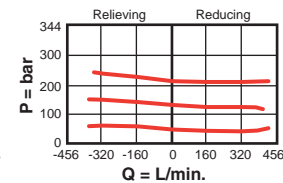

- Maximum operating pressure = 350 bar
- Control pilot flow = PPDB-8: 0,11 to 0,16 L/min., PPFB-8: 0,16 to 0,25 L/min., PPHB-8, PPJB-8: 0,25 to 0,33 L/min.
- Pressure at port 3 is directly additive to the valve setting at a 1:1 ratio and should not exceed 210 bar.
- Maximum inlet pressure is determined by the bias spring. The D spring is limited to 140 bar maximum differential pressure and the W spring is limited to 350 bar maximum inlet pressure.
- With the -8 control option, the main stage valve should first be installed to the correct torque value. The T-8A pilot control valve should then be installed into the main stage valve to its required torque value.

PP ★ B - 8 ★ ★

Nominal Capacity	Control	Minimum Control Pressure	Seal
D 40 L/min.	8 T-8A Cavity in hex body for pilot operation (Pilot valve to be ordered separately)	D 1,7 bar	N Buna-N
F 80 L/min.		W 7 bar	V Viton
H 160 L/min.			
J 320 L/min.			

Visit www.sunhydraulics.com for detailed and complete technical information on our full line of products.

Reducing and Reducing/Relieving Valves

3-WAY, EXTERNALLY DRAINED, MODULATING ELEMENT WITH INTEGRAL PILOT CONTROL CAVITY

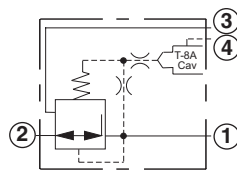
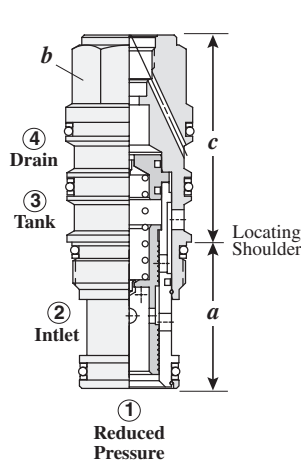

The -8 control option allows a pilot control valve to be incorporated directly into the end of the modulating element via the T-8A cavity. These pilot control cartridges are sold separately and include electro-proportional, solenoid, air pilot, and hydraulic pilot operation. See Pilot Control Cartridges on page 121.

Capacity	Typical Cartridge Model Code	Cavity	Cartridge Dimensions			Installation Torque (Nm)
			a	b	c	
40 L/min.	PVDA - 8WN	T - 21A	34,9	22,2	45,2	40/50
80 L/min.	PVFA - 8WN	T - 22A	34,9	28,6	50,8	60/70
160 L/min.	PVHA - 8WN	T - 23A	46,0	31,8	65,8	200/215
320 L/min.	PVJA - 8WN	T - 24A	63,5	41,3	80,3	465/500

Performance Curves

PVDA-8

PVFA-8

PVHA-8

PVJA-8

Regulated Pressure with T-8A Pilot Stage Installed

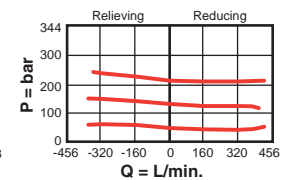
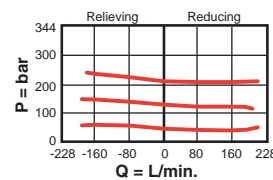
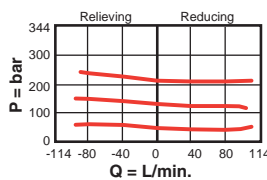
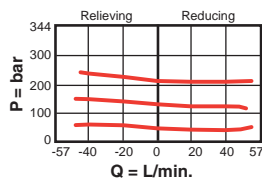

- Maximum operating pressure = 350 bar
- Control pilot flow = PVDA-8: 0,11 to 0,16 L/min., PVFA-8: 0,16 to 0,25 L/min., PVHA-8, PVJA-8: 0,25 to 0,33 L/min.
- Maximum pressure at port 3 should be limited to 210 bar.
- Pressure on the drain (port 4) is directly additive to the valve setting at a 1:1 ratio and should not exceed 350 bar.
- Maximum inlet pressure is determined by the bias spring. The D spring is limited to 140 bar maximum differential pressure and the W spring is limited to 350 bar maximum inlet pressure.
- With the -8 control option, the main stage valve should first be installed to the correct torque value. The T-8A pilot control valve should then be installed into the main stage valve to its required torque value.

PV ★ A - 8 ★ ★

Nominal Capacity	Control	Minimum Control Pressure	Seal
D 40 L/min.	8 T-8A Cavity in hex body for pilot operation (Pilot valve to be ordered separately)	D 1,7 bar	N Buna-N
F 80 L/min.		W 7 bar	V Viton
H 160 L/min.			
J 320 L/min.			

Visit www.sunhydraulics.com for detailed and complete technical information on our full line of products.

ELECTRO-PROPORTIONAL, DIRECT ACTING REDUCING/RELIEVING

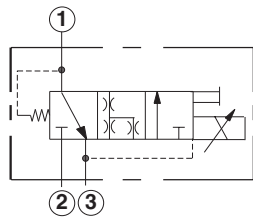
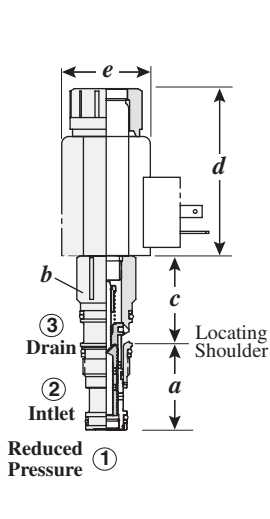

Capacity	Typical Cartridge Model Code	Cavity	Cartridge Dimensions					Installation Torque (Nm)
			a	b	c	d	e (dia.)	
20 L/min.	PRDL - MDN	T-11A	35,1	22,2	38,1	70,1	37,3	45/50

Performance Curves

PRDL

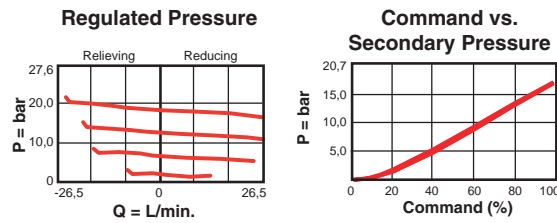

- Maximum operating pressure = 350 bar
- Maximum valve leakage = 328 cc/min. at deadhead
- Pressure at port 3 is directly additive to the valve setting at a 1:1 ratio and should not exceed 210 bar.
- For optimum performance, an amplifier with current sensing and adjustable dither should be used. Dither should be adjustable between 100 - 250 Hz.

PRDL - MDN

Nominal Capacity	Control	Operating Range	Seal
L 20 L/min.	M Manual Override (Standard)	D 3,5 - 35 bar	N Buna-N
		E 1,7 - 18 bar	V Viton
		S 0,7 - 7 bar	

NOTE: Coil must be ordered separately. Use 12V DC or 24V DC (Series 770-***) coils only. See page 167.

Visit www.sunhydraulics.com for detailed and complete technical information on our full line of products.

ELECTRO-PROPORTIONAL, DIRECT ACTING WITH LOW LEAKAGE

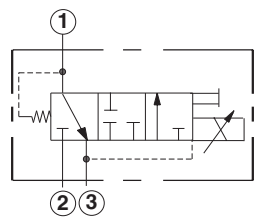
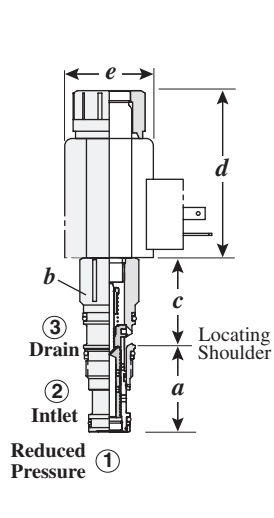

Capacity	Typical Cartridge Model Code	Cavity	Cartridge Dimensions					Installation Torque (Nm)
			a	b	c	d	e (dia.)	
20 L/min.	PRDP - MDN	T-11A	35,1	22,2	38,1	70,1	37,3	45/50

Performance Curves

PRDP

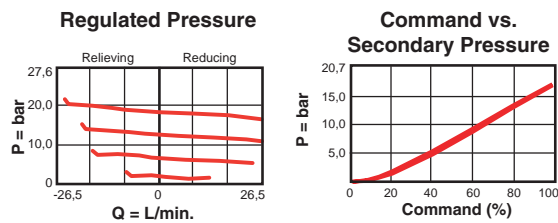

- Maximum operating pressure = 350 bar
- Maximum valve leakage = 32.8 cc/min. at deadhead
- Pressure at port 3 is directly additive to the valve setting at a 1:1 ratio and should not exceed 210 bar.
- For optimum performance, an amplifier with current sensing and adjustable dither should be used. Dither should be adjustable between 100 - 250 Hz.

PRDP - MDN

<p>Nominal Capacity</p> <p>P 20 L/min.</p>	<p>Control</p> <p>M Manual Override (Standard)</p> <p>NOTE: Coil must be ordered separately. Use 12V DC or 24V DC (Series 770-***) coils only. See page 167.</p>	<p>Operating Range</p> <p>D 3,5 - 35 bar</p> <p>E 1,7 - 18 bar</p>	<p>Seal</p> <p>N Buna-N</p> <p>V Viton</p>
--	--	---	---

Visit www.sunhydraulics.com for detailed and complete technical information on our full line of products.

Pilot Operated Check Cartridge Valves

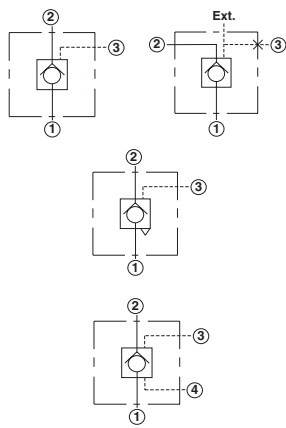

Cartridge Type

Page

Pilot Operated

44

Atmospherically Referenced,
3 Port Cavity

45

Vented, 4 Port Cavity

46

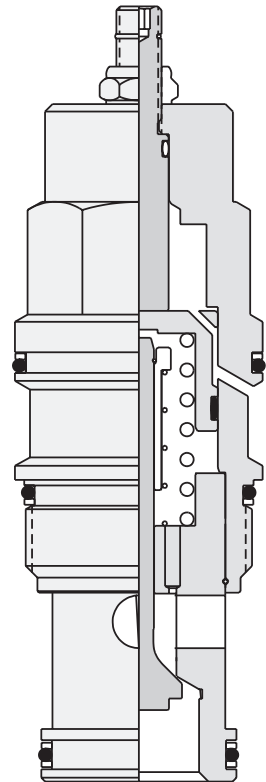

Pilot Operated Check Valves

PILOT OPERATED

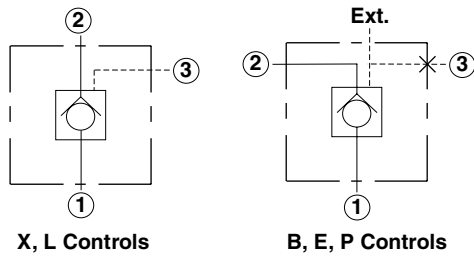
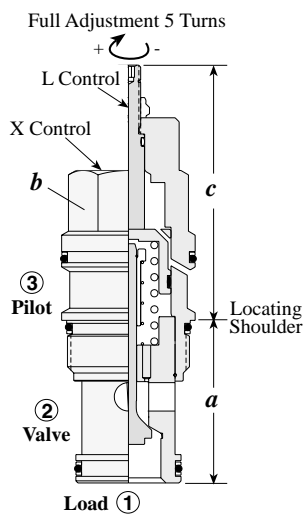

Capacity	Typical Cartridge Model Code	Cavity	Cartridge Dimensions				Installation Torque (Nm)
			a	b	X,B,E,P	L	
30 L/min.	CKBB - XCN	T - 163A	31	19,1	32	43	35/40
60 L/min.	CKCB - XCN	T - 11A	34,9	22,2	31	62	40/50
120 L/min.	CKEB - XCN	T - 2A	34,9	28,6	35	72	60/70
240 L/min.	CKGB - XCN	T - 17A	46	31,8	46	84	200/215
480 L/min.	CKIB - XCN	T - 19A	63,5	41,3	59	100	465/500

Performance Curves

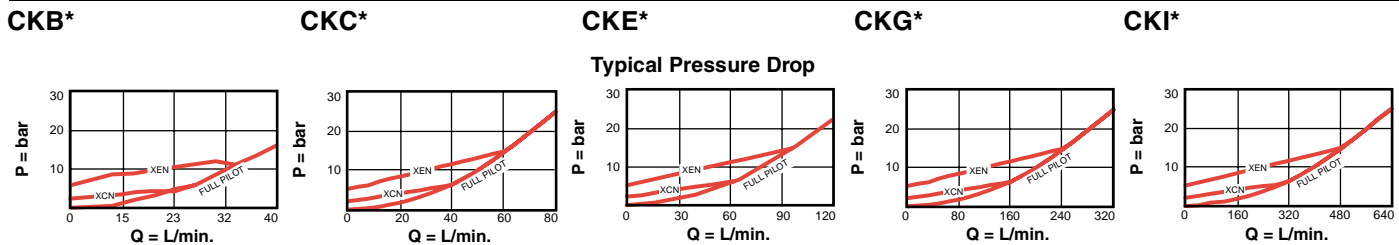

- Maximum operating pressure = 350 bar
- Maximum valve leakage = 0,07 cc/min.
- CKBB, CKBD available only with 2 bar or 5 bar check valve cracking pressures.
- CK*D has sealed pilot for use in circuits where cross port leakage is undesirable.
- CK*B has unsealed pilot to allow air trapped in the pilot line to be purged from the circuit.

Nominal Capacity	Version	Control**	Cracking Pressure	Seal
B * 30 L/min.	B Bleed through Pilot	X Standard Pilot	A 0,3 bar	N Buna-N
C 60 L/min.	D Sealed Pilot Piston	L Manual Load Release	B 1,0 bar	V Viton
E 120 L/min.		B 1/4" BSPP External Pilot Port 3 blocked	C 2,0 bar	
G 240 L/min.		E SAE-4 External Pilot Port 3 blocked	D 3,5 bar	
I 480 L/min.		P 1/4" NPTF External Pilot Port 3 blocked	E 5,0 bar	
			F 7,0 bar	

** See page 162 for information on Control Options

* CKBB, CKBD available with C and E Cracking Pressures Only.

Visit www.sunhydraulics.com for detailed and complete technical information on our full line of products.

ATMOSPHERICALLY REFERENCED, 3 PORT CAVITY

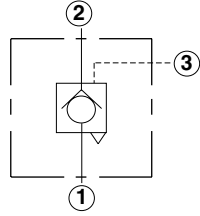
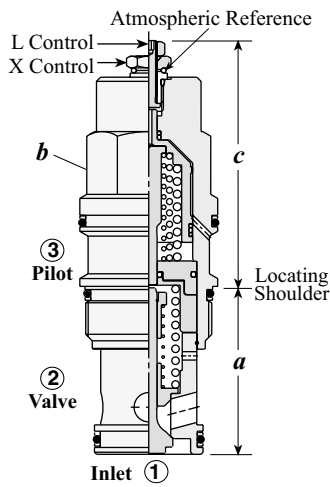

Capacity	Typical Cartridge Model Code	Cavity	Cartridge Dimensions					Installation Torque (Nm)
			a	b	c			
					X	L	S	
60 L/min.	CKCV – XCN	T - 11A	34,9	22,2	51	57	43	40/50
120 L/min.	CKEV – XCN	T - 2A	34,9	28,6	59	65	51	60/70
240 L/min.	CKGV – XCN	T - 17A	46	31,8	71	77	63	200/215
480 L/min.	CKIV – XCN	T - 19A	63,5	41,3	84	96	84	465/500

Performance Curves

CKCV

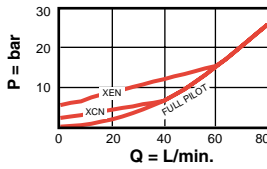

CKEV

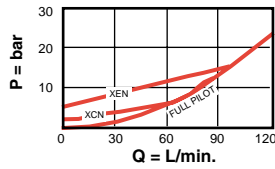

CKGV

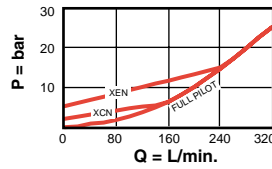

CKIV

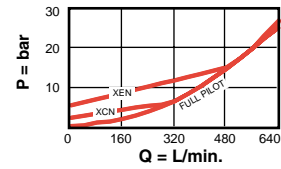

Typical Pressure Drop

- Maximum operating pressure = 350 bar
- Maximum valve leakage = 0,07 cc/min.
- Approximately 0,07 cc of fluid will pass from the pilot area to the vented spring chamber every 4000 cycles.

CK ★ V – ★ ★ ★

Nominal Capacity	Control**	Cracking Pressure	Seal
C 60 L/min.	X Standard Pilot	A 0,3 bar	N Buna-N
E 120 L/min.	S External SAE-4 Vent Port	B 1,0 bar	V Viton
G 240 L/min.	L Manual Load Release External Vent	C 2,0 bar	
I 480 L/min.		D 3,5 bar	
		E 5,0 bar	
		F 7,0 bar	

** See page 162 for information on Control Options

Visit www.sunhydraulics.com for detailed and complete technical information on our full line of products.

Pilot Operated Check Valves

VENTED, 4 PORT CAVITY

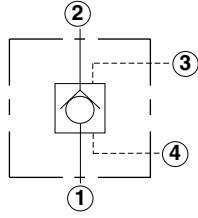
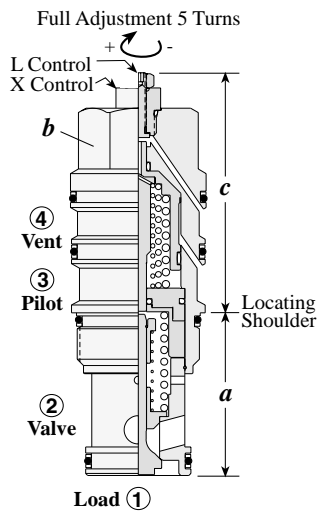

Capacity	Typical Cartridge Model Code	Cavity	Cartridge Dimensions				Installation Torque (Nm)
			a	b	c		
60 L/min.	CVCV – XCN	T - 21A	34,9	22,2	X 54	L 60	40/50
120 L/min.	CVEV – XCN	T - 22A	34,9	28,6	X 60	L 65	60/70
240 L/min.	CVGV – XCN	T - 23A	46	31,8	X 72	L 77	200/215
480 L/min.	CVIV – XCN	T - 24A	63,5	41,3	X 89	L 96	465/500

Performance Curves

CVCV

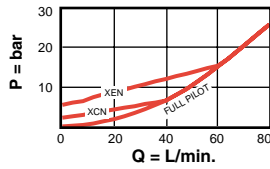

CVEV

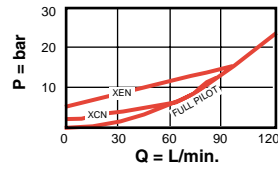

CVGV

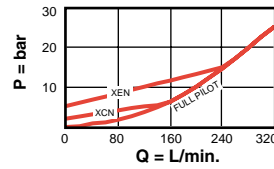

CVIV

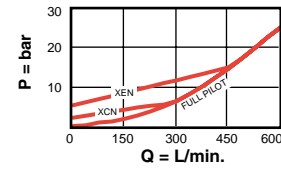

Typical Pressure Drop

- Maximum operating pressure = 350 bar
- Maximum valve leakage = 0,07 cc/min.
- Port 4 (vent) should never be blocked as seal weepage will eventually cause valve to malfunction.
- Will accept pressure at port 4 (vent) but cannot exceed 350 bar.

CV ★ V – ★ ★ ★

Nominal Capacity	Control**	Adjustment Range	Seal
C 60 L/min.	X Standard Pilot	A 0,3 bar	N Buna-N
E 120 L/min.	L Manual Load Release	B 1,0 bar	V Viton
G 240 L/min.		C 2,0 bar	
I 480 L/min.		D 3,5 bar	
		E 5,0 bar	
		F 7,0 bar	

** See page 162 for information on Control Options

Visit www.sunhydraulics.com for detailed and complete technical information on our full line of products.

Counterbalance Cartridge Valves

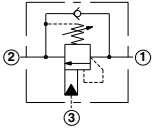
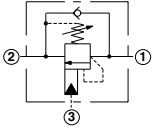
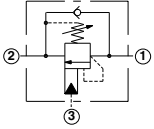
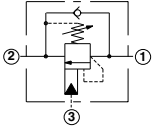
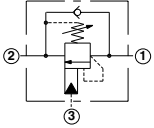
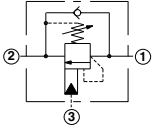
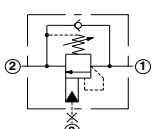
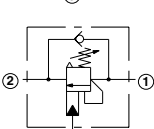
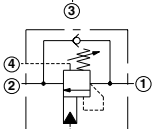
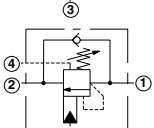
	<i>Cartridge Type</i>	<i>Page</i>
	Standard, 280 Bar Maximum Setting	48
	Standard, 350 Bar Maximum Setting	49
	Semi-Restrictive, 280 Bar Maximum Setting	50
	Semi-Restrictive, 350 Bar Maximum Setting	51
	Restrictive, 280 Bar Maximum Setting	52
	Restrictive, 350 Bar Maximum Setting	53
	Without Pilot Assist, 3 Port Cavity	54
	Atmospherically Referenced, 3 Port Cavity	55
	Vented, 280 Bar Maximum Setting	56
	Vented, 420 Bar Maximum Setting	57

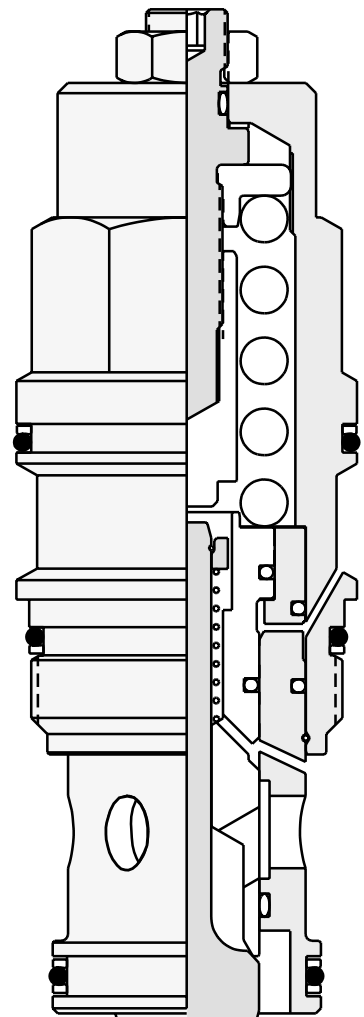

STANDARD, 280 BAR MAXIMUM SETTING

Turn screw clockwise to reduce setting and release load.
Complete Adjustment 3 3/4 Turns

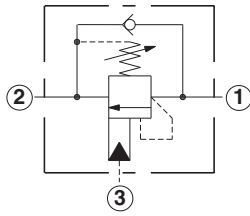
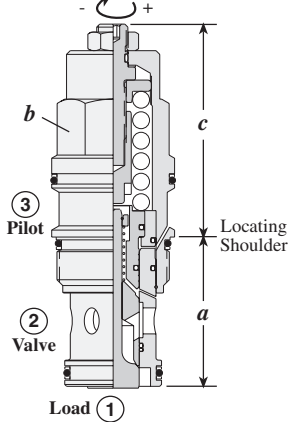

Capacity	Typical Cartridge Model Code	Cavity	Cartridge Dimensions				Installation Torque (Nm)
			a	b	L	C	
60 L/min.	CBCA – LHN	T - 11A	34,9	22,2	50	56	40/50
120 L/min.	CBEA – LHN	T - 2A	34,9	28,6	61	64	60/70
240 L/min.	CBGA – LHN	T - 17A	46	31,8	70	84	200/215
480 L/min.	CBIA – LHN	T - 19A	63,5	41,3	90	104	465/500

Performance Curves

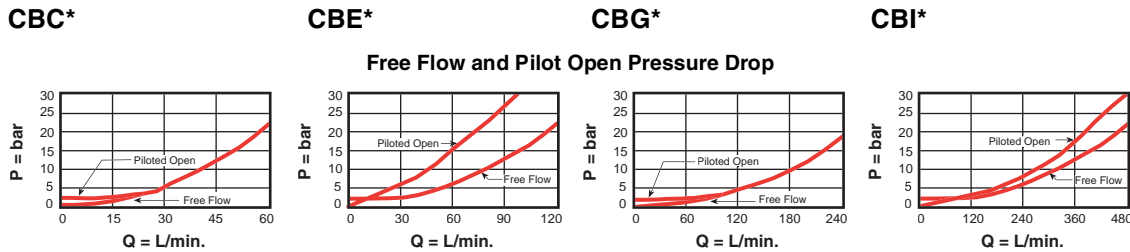

- Load holding to 215 bar with 280 bar valve setting
- Maximum valve leakage at reseal = 0,4 cc/min.
- Reseat exceeds 85% of set pressure
- Factory pressure setting established at 32,8 cc/min.
- Counterbalance valves should be set at least 1.3 times the maximum load induced pressure.
- Back pressure at port 2 adds to the effective relief setting at a ratio of 1 plus the pilot ratio times the back pressure.

CB ★★ – ★★★

Nominal Capacity	Version	Control**	Cracking Pressure	Seal
C 60 L/min.	A 3:1 Pilot Ratio	L Standard Screw	1,7 Bar Check Spring	N Buna-N
E 120 L/min.	B 1.5:1 Pilot Ratio (with sealed pilot)	C Tamper Resistant	H 70 - 280 bar	V Viton
G 240 L/min.	Y 2:1 Pilot Ratio (with Bleed through Pilot)		I 25 - 105 bar	
I 480 L/min.			0,3 Bar Check Spring	
			A 70 - 280 bar	
			B 25 - 105 bar	

Adjustment Range Options:
A and H are standard set at 210 bar.
I and B are standard set at 70 bar.
Customer may specify setting.

** See page 162 for information on Control Options

Visit www.sunhydraulics.com for detailed and complete technical information on our full line of products.

STANDARD, 350 BAR MAXIMUM SETTING

Turn screw clockwise to reduce setting and release load.
Complete Adjustment 3 3/4 Turns

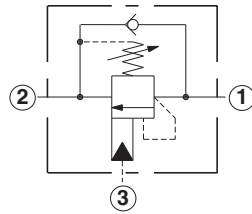
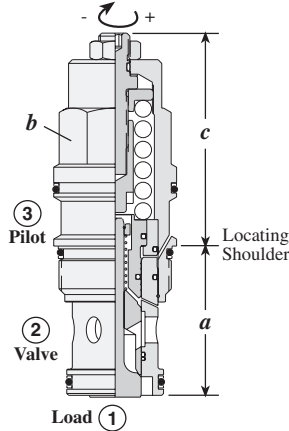

Capacity	Typical Cartridge Model Code	Cavity	Cartridge Dimensions				Installation Torque (Nm)
			<i>a</i>	<i>b</i>	<i>c</i> L C		
60 L/min.	CBCG – LJN	T - 11A	34,9	22,2	50 56	40/50	
120 L/min.	CBEG – LJN	T - 2A	34,9	28,6	61 64	60/70	
240 L/min.	CBGG – LJN	T - 17A	46	31,8	70 84	200/215	
480 L/min.	CBIG – LJN	T - 19A	63,5	41,3	90 104	465/500	

Performance Curves

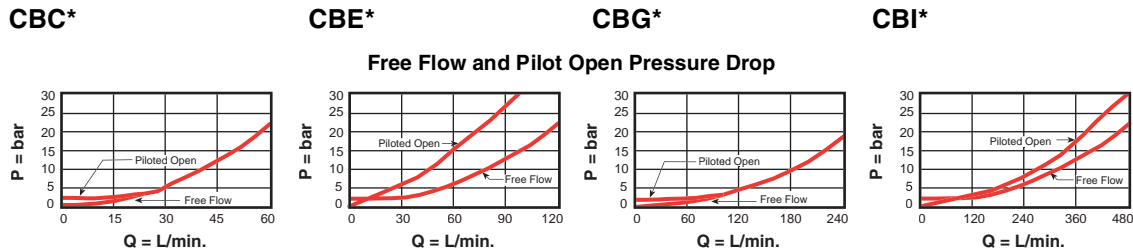

- Load holding to 270 bar with 350 bar valve setting
- Maximum valve leakage at reseal = 0,4 cc/min.
- Reseat exceeds 85% of set pressure
- Factory pressure setting established at 32,8 cc/min.
- Counterbalance valves should be set at least 1.3 times the maximum load induced pressure.
- Back pressure at port 2 adds to the effective relief setting at a ratio of 1 plus the pilot ratio times the back pressure.

CB ★★ – ★★

Nominal Capacity	Version	Control**	Cracking Pressure	Seal
C 60 L/min.	G 4.5:1 Pilot Ratio	L Standard Screw	J 1,7 Bar Check Spring	N Buna-N
E 120 L/min.	H 10:1 Pilot Ratio	C Tamper Resistant	J 140 - 350 bar	V Viton
G 240 L/min.	L 2.3:1 Pilot Ratio (with sealed pilot)		K 70 - 175 bar	
I 480 L/min.			0,3 Bar Check Spring	
			C 140 - 350 bar	
			D 70 - 175 bar	

Adjustment Range Options:
J and C are standard set at 210 bar.
K and D are standard set at 140 bar.
Customer may specify setting.

** See page 162 for information on Control Options

Visit www.sunhydraulics.com for detailed and complete technical information on our full line of products.



Counterbalance Valves

SEMI-RESTRICTIVE, 280 BAR MAXIMUM SETTING

Turn screw clockwise to reduce setting and release load.
Complete Adjustment 3 3/4 Turns

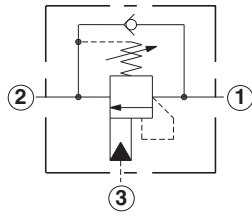
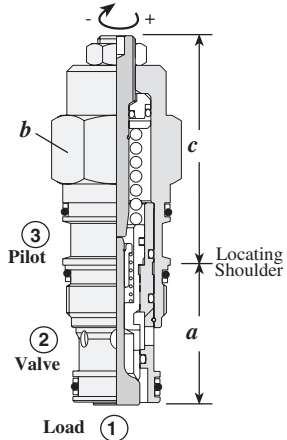

Capacity	Typical Cartridge Model Code	Cavity	Cartridge Dimensions				Installation Torque (Nm)
			a	b	L	C	
40 L/min.	CBBC – LHN	T - 11A	34,9	22,2	50	56	40/50
80 L/min.	CBDC – LHN	T - 2A	34,9	28,6	61	64	60/70
160 L/min.	CBFC – LHN	T - 17A	46	31,8	70	84	200/215

Performance Curves

CBB*

CBD*

CBF*

Free Flow and Pilot Open Pressure Drop

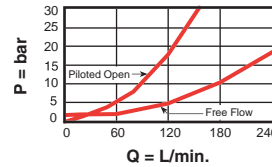
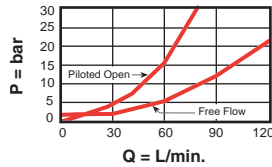
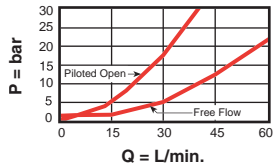

- Load holding to 215 bar with 280 bar valve setting
- Maximum valve leakage at reseal = 0,4 cc/min.
- Reseat exceeds 85% of set pressure
- Factory pressure setting established at 32,8 cc/min.
- Counterbalance valves should be set at least 1.3 times the maximum load induced pressure.
- Back pressure at port 2 adds to the effective relief setting at a ratio of 1 plus the pilot ratio times the back pressure.

CB ★ ★ - ★ ★ ★

<p>Nominal Capacity</p> <p>B 40 L/min.</p> <p>D 80 L/min.</p> <p>F 160 L/min.</p>	<p>Version</p> <p>B 1.5:1 Pilot Ratio (with sealed pilot)</p> <p>C 3:1 Pilot Ratio (with sealed pilot)</p>	<p>Control**</p> <p>L Standard Screw</p> <p>C Tamper Resistant</p>	<p>Cracking Pressure</p> <p>I,7 Bar Check Spring</p> <p>H 70 - 280 bar</p> <p>I 25 - 105 bar</p> <p>0,3 Bar Check Spring</p> <p>A 70 - 280 bar</p> <p>B 25 - 105 bar</p>	<p>Seal</p> <p>N Buna-N</p> <p>V Viton</p>
---	---	---	---	---

Adjustment Range Options:
 A and H are standard set at 210 bar.
 I and B are standard set at 70 bar.
Customer may specify setting.

** See page 162 for information on Control Options

Visit www.sunhydraulics.com for detailed and complete technical information on our full line of products.

Counterbalance Valves

SEMI-RESTRICTIVE, 350 BAR MAXIMUM SETTING

Turn screw clockwise to reduce setting and release load.
Complete Adjustment 3 3/4 Turns

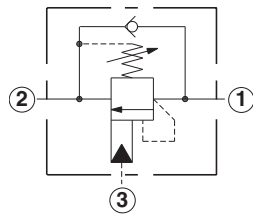
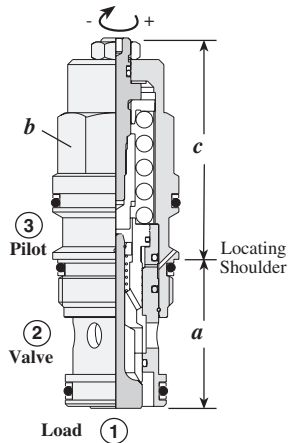

Capacity	Typical Cartridge Model Code	Cavity	Cartridge Dimensions				Installation Torque (Nm)
			a	b	L	C	
40 L/min.	CBBD – LJN	T - 11A	34,9	22,2	50	56	40/50
80 L/min.	CBDD – LJN	T - 2A	34,9	28,6	61	64	60/70
160 L/min.	CBFD – LJN	T - 17A	46	31,8	70	84	200/215

Performance Curves

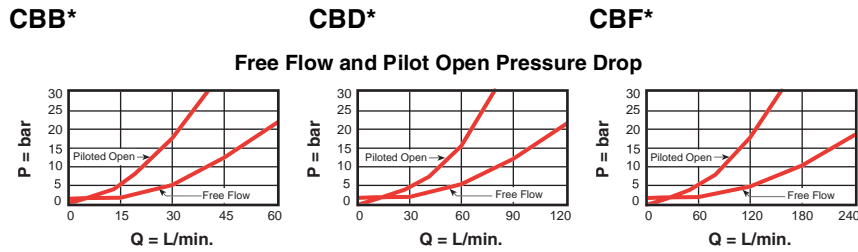

- Load holding to 270 bar with 350 bar valve setting
- Maximum valve leakage at reseal = 0,4 cc/min.
- Reseat exceeds 85% of set pressure
- Factory pressure setting established at 32,8 cc/min.
- Counterbalance valves should be set at least 1.3 times the maximum load induced pressure.
- Back pressure at port 2 adds to the effective relief setting at a ratio of 1 plus the pilot ratio times the back pressure.

CB** **—** *******

<p>Nominal Capacity</p> <p>B 40 L/min.</p> <p>D 80 L/min.</p> <p>F 160 L/min.</p>	<p>Version</p> <p>D 4.5:1 Pilot Ratio (with sealed pilot)</p> <p>L 2.3:1 Pilot Ratio (with sealed pilot)</p>	<p>Control**</p> <p>L Standard Screw</p> <p>C Tamper Resistant</p>	<p>Cracking Pressure</p> <p>J 140 - 350 bar</p> <p>K 70 - 175 bar</p> <p>0,3 Bar Check Spring</p> <p>C 140 - 350 bar</p> <p>D 70 - 175 bar</p>	<p>Seal</p> <p>N Buna-N</p> <p>V Viton</p>
---	---	---	--	---

Adjustment Range Options:
 J and C are standard set at 210 bar.
 K and D are standard set at 140 bar.
Customer may specify setting.

** See page 162 for information on Control Options

Visit www.sunhydraulics.com for detailed and complete technical information on our full line of products.



RESTRICTIVE, 280 BAR MAXIMUM SETTING

Turn screw clockwise to reduce setting and release load.
Complete Adjustment 3 3/4 Turns

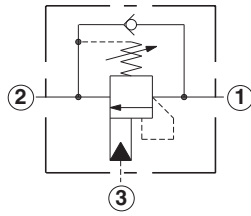
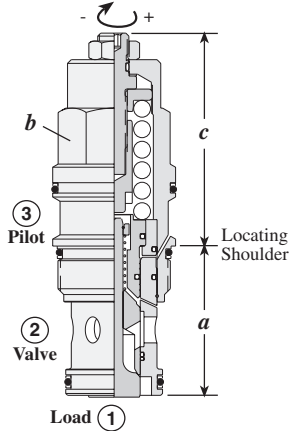

Capacity	Typical Cartridge Model Code	Cavity	Cartridge Dimensions				Installation Torque (Nm)
			a	b	L	C	
15 L/min.	CBBA – LHN	T - 11A	34,9	22,2	50	56	40/50
30 L/min.	CBDA – LHN	T - 2A	34,9	28,6	61	64	60/70
60 L/min.	CBFA – LHN	T - 17A	46	31,8	70	84	200/215
80 L/min.	CBHA – LHN	T - 19A	63,5	41,3	90	104	465/500

Performance Curves

CBB*

CBD*

CBF*

CBH*

Free Flow and Pilot Open Pressure Drop

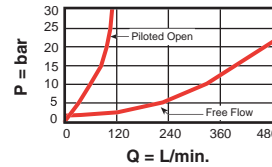
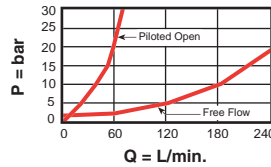
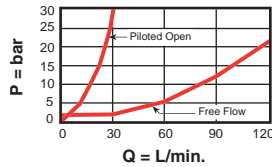
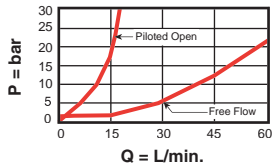

- Restrictive valves have no relief capacity other than as a thermal relief.
- Load holding to 215 bar with 280 bar valve setting
- Maximum valve leakage at reseal = 0,4 cc/min.
- Reseat exceeds 85% of set pressure
- Factory pressure setting established at 32,8 cc/min.
- Counterbalance valves should be set at least 1.3 times the maximum load induced pressure.
- Back pressure at port 2 adds to the effective relief setting at a ratio of 1 plus the pilot ratio times the back pressure.

CB - *****

Nominal Capacity	Version	Control**	Cracking Pressure	Seal
B 15 L/min.	A 3:1 Pilot Ratio (with sealed pilot)	L Standard Screw	1,7 Bar Check Spring	N Buna-N
D 30 L/min.		C Tamper Resistant	H 70 - 280 bar	V Viton
F 60 L/min.	Available in CBBY only		I 25 - 105 bar	
H 80 L/min.	Y 2:1 Pilot Ratio (with Bleed through Pilot)		0,3 Bar Check Spring	
			A 70 - 280 bar	
			B 25 - 105 bar	

Adjustment Range Options:
A and H are standard set at 210 bar.
I and B are standard set at 70 bar.
Customer may specify setting.

** See page 162 for information on Control Options

Visit www.sunhydraulics.com for detailed and complete technical information on our full line of products.

RESTRICTIVE, 350 BAR MAXIMUM SETTING

Turn screw clockwise to reduce setting and release load.
Complete Adjustment 3 3/4 Turns

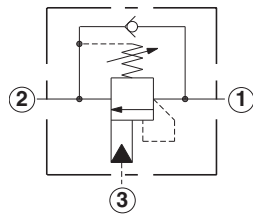
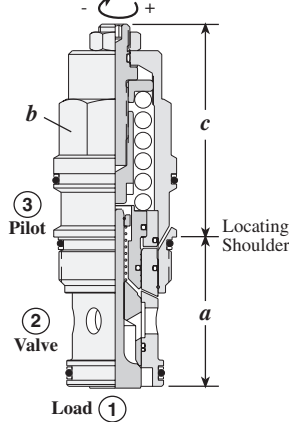

Capacity	Typical Cartridge Model Code	Cavity	Cartridge Dimensions				Installation Torque (Nm)
			a	b	L	C	
15 L/min.	CBBG – LJN	T - 11A	34,9	22,2	50	56	40/50
30 L/min.	CBDG – LJN	T - 2A	34,9	28,6	61	64	60/70
60 L/min.	CBFG – LJN	T - 17A	46	31,8	70	84	200/215
80 L/min.	CBHG – LJN	T - 19A	63,5	41,3	90	104	465/500

Performance Curves

CBB*

CBD*

CBF*

CBH*

Free Flow and Pilot Open Pressure Drop

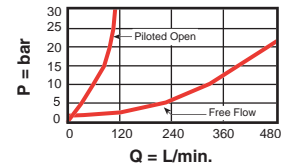
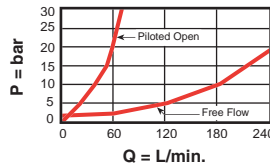
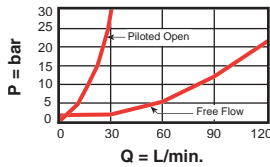
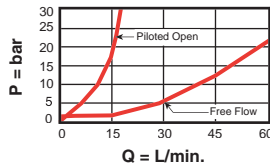

- Restrictive valves have no relief capacity other than as a thermal relief.
- Load holding to 270 bar with 350 bar valve setting
- Maximum valve leakage at reseal = 0,4 cc/min.
- Reseat exceeds 85% of set pressure
- Factory pressure setting established at 32,8 cc/min.
- Counterbalance valves should be set at least 1.3 times the maximum load induced pressure.
- Back pressure at port 2 adds to the effective relief setting at a ratio of 1 plus the pilot ratio times the back pressure.

CB**

Nominal Capacity	Version	Control**	Cracking Pressure	Seal
B 15 L/min.	G 4.5:1 Pilot Ratio (with sealed pilot)	L Standard Screw	J 140 - 350 bar	N Buna-N
D 30 L/min.		C Tamper Resistant	K 70 - 175 bar	V Viton
F 60 L/min.			0,3 Bar Check Spring	
H 80 L/min.			C 140 - 350 bar	
			D 70 - 175 bar	

Adjustment Range Options:
J and C are standard set at 210 bar.
K and D are standard set at 140 bar.
Customer may specify setting.

** See page 162 for information on Control Options

Visit www.sunhydraulics.com for detailed and complete technical information on our full line of products.



WITHOUT PILOT ASSIST, 3 PORT CAVITY

Turn screw clockwise to reduce setting and release load.
Complete Adjustment 3-3/4 Turns

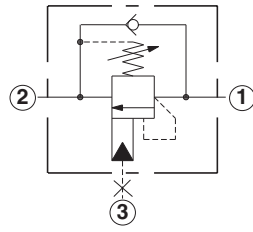
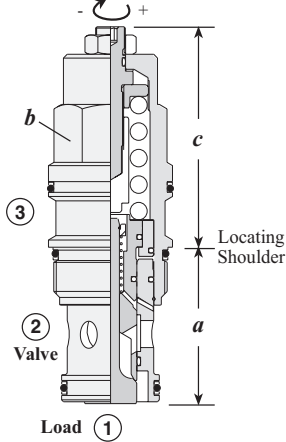

Capacity	Typical Cartridge Model Code	Cavity	Cartridge Dimensions				Installation Torque (Nm)
			a	b	L	C	
60 L/min.	CCCA – LAN	T - 11A	34,9	22,2	50	56	40/50
120 L/min.	CCEA – LAN	T - 2A	34,9	28,6	61	73	60/70
240 L/min.	CCGA – LAN	T - 17A	46	31,8	70	84	200/215
480 L/min.	CCIA – LAN	T - 19A	63,5	41,3	90	104	465/500

Performance Curves

CCCA

CCEA

CCGA

CCIA

Typical Relief Characteristics

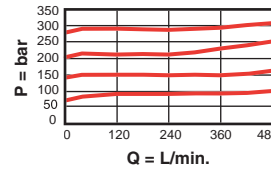
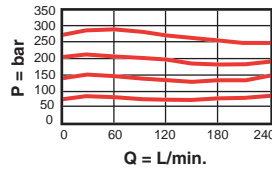
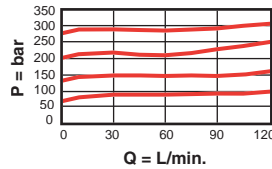
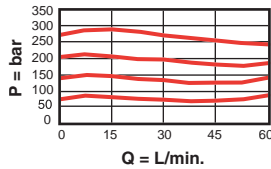

- Maximum operating pressure = 280 bar
- Maximum valve leakage at reseal = 0,4 cc/min.
- Reseat exceeds 85% of set pressure
- Factory pressure setting established at 32,8 cc/min.
- Counterbalance valves should be set at least 1.3 times the maximum load induced pressure.
- Back pressure at port 2 is directly additive to the relief setting of the valve.

CC * A - * * *

Nominal Capacity	Version	Control**	Cracking Pressure	Seal
C 60 L/min.	A Standard	L Standard Screw	1,7 Bar Check Spring	N Buna-N
E 120 L/min.		C Tamper Resistant	H 70 - 280 bar	V Viton
G 240 L/min.			I 25 - 105 bar	
I 480 L/min.			0,3 Bar Check Spring	
			A 70 - 280 bar	
			B 25 - 105 bar	

Adjustment Range Options:
A and H are standard set at 210 bar.
I and B are standard set at 70 bar.
Customer may specify setting.

** See page 162 for information on Control Options

Visit www.sunhydraulics.com for detailed and complete technical information on our full line of products.

ATMOSPHERICALLY REFERENCED, 3 PORT CAVITY

Turn screw clockwise to reduce setting and release load.
Complete Adjustment 4 Turns

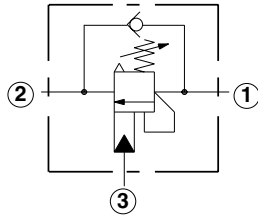
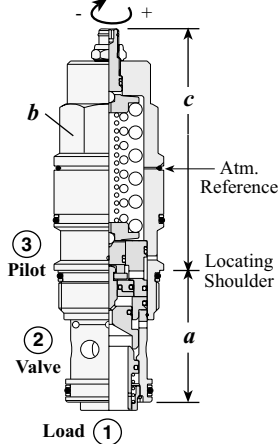

Capacity	Typical Cartridge Model Code	Cavity	Cartridge Dimensions				Installation Torque (Nm)
			a	b	L	C	
60 L/min.	CACA – LHN	T - 11A	34,9	22,2	74	81	40/50
120 L/min.	CAEA – LHN	T - 2A	34,9	28,6	84	90	60/70
240 L/min.	CAGA – LHN	T - 17A	46	31,8	96	101	200/215
480 L/min.	CAIA – LHN	T - 19A	63,5	41,3	117	126	465/500

Performance Curves

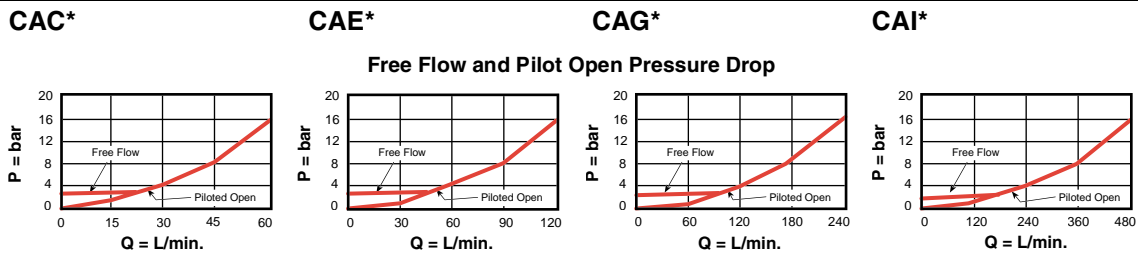

- Load holding to 210 bar with 280 bar valve setting for CA*A, CA*K; 320 bar with 420 bar valve setting for CA*G, CA*L.
- Maximum valve leakage at reseal = 0,4 cc/min.
- Reseat exceeds 85% of set pressure
- Factory pressure setting established at 32,8 cc/min.
- Free flow check cracking pressure = 2,8 bar
- Counterbalance valves should be set at least 1.3 times the maximum load induced pressure.

CA**

Nominal Capacity	Version	Control**	Cracking Pressure	Seal
C 60 L/min.	A 3:1 Pilot Ratio	L Standard Screw	A and K Pilot Ratios	N Buna-N
E 120 L/min.	G 5:1 Pilot Ratio	C Tamper Resistant	H 70 - 280 bar	V Viton
G 240 L/min.	K 1:1 Pilot Ratio		I 25 - 105 bar	
I 480 L/min.	L 2:1 Pilot Ratio		G and L Pilot Ratios	
			F 70 - 175 bar	
			G 140 - 420 bar	

Adjustment Range Options:
H is standard set at 210 bar.
I is standard set at 70 bar.
F is standard set at 140 bar.
G is standard set at 280 bar.
Customer may specify setting.

** See page 162 for information on Control Options

Visit www.sunhydraulics.com for detailed and complete technical information on our full line of products.



Counterbalance Valves

VENTED, 280 BAR MAXIMUM SETTING

Turn screw clockwise to reduce setting and release load. Complete Adjustment 4 Turns

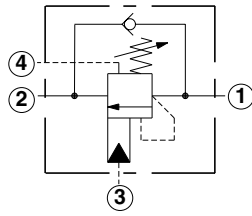
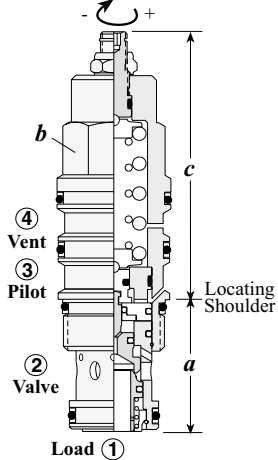

Capacity	Typical Cartridge Model Code	Cavity	Cartridge Dimensions				Installation Torque (Nm)
			a	b	L	C	
60 L/min.	CWCA- LHN	T - 21A	34,9	22,2	74	81	40/50
120 L/min.	CWEA- LHN	T - 22A	34,9	28,6	84	90	60/70
240 L/min.	CWGA- LHN	T - 23A	46	31,8	96	101	200/215
480 L/min.	CWIA - LHN	T - 24A	63,5	41,3	117	126	465/500

Performance Curves

CWC*

CWE*

CWG*

CWI*

Free Flow and Pilot Open Pressure Drop

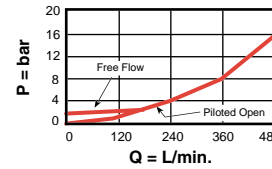
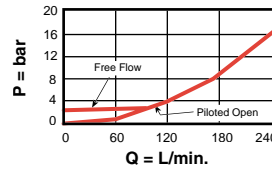
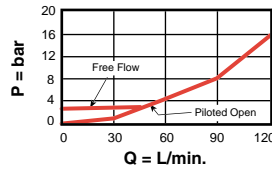
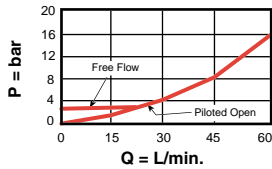

- Load holding to 210 bar with 280 bar valve setting
- Maximum valve leakage at reseal = 0,4 cc/min.
- Reseat exceeds 85% of set pressure
- Factory pressure setting established at 32,8 cc/min.
- Free flow check cracking pressure = 2,8 bar
- Counterbalance valves should be set at least 1.3 times the maximum load induced pressure.

CW ★ ★

- ★ ★ ★

Nominal Capacity	Version	Control**	Cracking Pressure	Seal
C 60 L/min.	A 3:1 Pilot Ratio	L Standard Screw	Pilot Ratios	N Buna-N
E 120 L/min.	K 1:1 Pilot Ratio	C Tamper Resistant	H 70 - 280 bar	V Viton
G 240 L/min.			I 25 - 105 bar	
I 480 L/min.				

Adjustment Range Options:
 H is standard set at 210 bar.
 I is standard set at 70 bar.
 Customer may specify setting.

** See page 162 for information on Control Options

Visit www.sunhydraulics.com for detailed and complete technical information on our full line of products.

Counterbalance Valves

VENTED, 420 BAR MAXIMUM SETTING

Turn screw clockwise to reduce setting and release load. Complete Adjustment 4 Turns

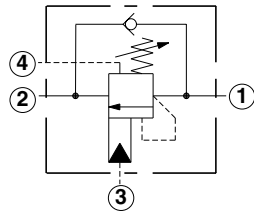
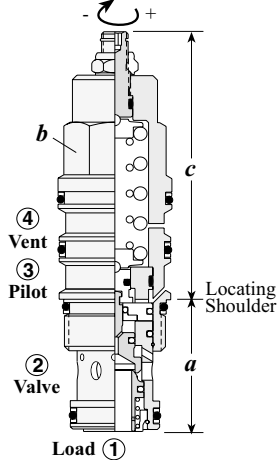

Capacity	Typical Cartridge Model Code	Cavity	Cartridge Dimensions				Installation Torque (Nm)
			a	b	L	C	
60 L/min.	CWCG- LFN	T - 21A	34,9	22,2	74	81	40/50
120 L/min.	CWEG- LFN	T - 22A	34,9	28,6	84	90	60/70
240 L/min.	CWGG- LFN	T - 23A	46	31,8	96	101	200/215
480 L/min.	CWIG - LFN	T - 24A	63,5	41,3	117	126	465/500

Performance Curves

CWC*

CWE*

CWG*

CWI*

Free Flow and Pilot Open Pressure Drop

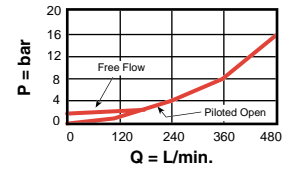
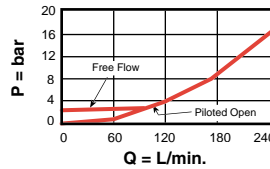
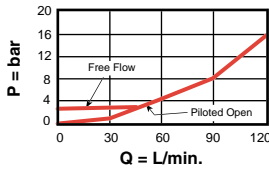
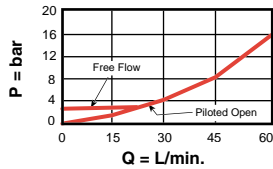

- Load holding to 320 bar with 420 bar valve setting
- Maximum valve leakage at reseal = 0,4 cc/min.
- Reseat exceeds 85% of set pressure
- Factory pressure setting established at 32,8 cc/min.
- Free flow check cracking pressure = 2,8 bar
- Counterbalance valves should be set at least 1.3 times the maximum load induced pressure.

CW ★ ★

- ★ ★ ★

Nominal Capacity	Version	Control**	Cracking Pressure	Seal
C 60 L/min.	G 5:1 Pilot Ratio	L Standard Screw	Pilot Ratios	N Buna-N
E 120 L/min.	L 2:1 Pilot Ratio	C Tamper Resistant	F 70 - 175 bar	V Viton
G 240 L/min.			G 140 - 420 bar	
I 480 L/min.				

Adjustment Range Options:
 F is standard set at 140 bar.
 G is standard set at 280 bar.
 Customer may specify setting.

** See page 162 for information on Control Options

Visit www.sunhydraulics.com for detailed and complete technical information on our full line of products.

Check Cartridge Valves

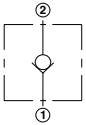
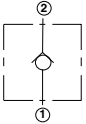
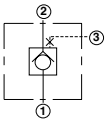
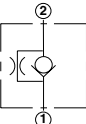
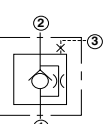
	<i>Cartridge Type</i>	<i>Page</i>
	Free Flow Nose to Side	60
	Free Flow Side to Nose	61
	Free Flow Side to Nose, Port 3 Blocked	62
	Free Flow Nose to Side with Bypass Orifice	63
	2 To 1 Free Flow, with Customer Specified Orifice, Port 3 Blocked, 3 Port Cavity	64

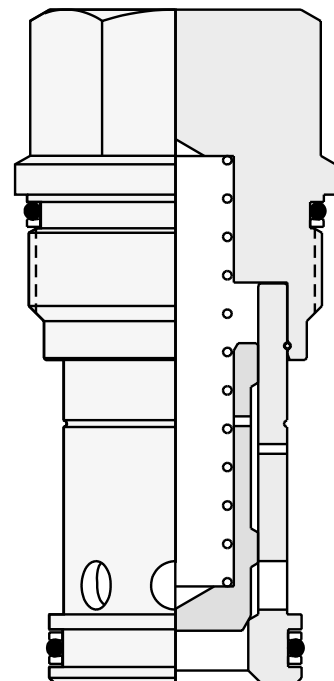

FREE FLOW NOSE TO SIDE

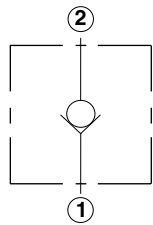
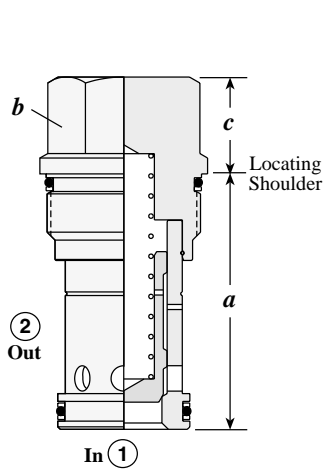

Capacity	Typical Cartridge Model Code	Cavity	Cartridge Dimensions			Installation Torque (Nm)
			a	b	c	
40 L/min.	CXBA – XCN	T - 162A	31	19,1	21	35/40
80 L/min.	CXDA – XCN	T - 13A	34,9	22,2	19	40/50
160 L/min.	CXFA – XCN	T - 5A	41,1	28,6	18	60/70
320 L/min.	CXHA – XCN	T - 16A	61,9	31,8	25	200/215
640 L/min.	CXJA – XCN	T - 18A	79,4	41,3	31	465/500

Performance Curves

CXBA

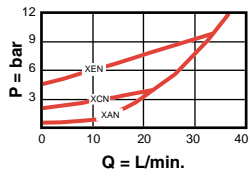

CXDA

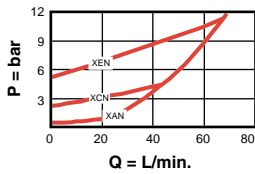

CXFA

Typical Pressure Drop

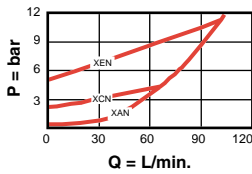

CXHA

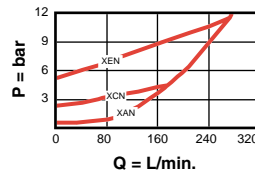

CXJA

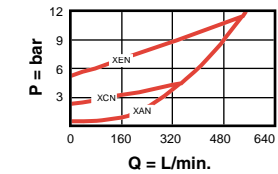

- Maximum operating pressure = 350 bar
- Maximum valve leakage = 0,07 cc/min.
- Will accept 350 bar at ports 1 and 2.

CX * A - * * *

Nominal Capacity	Control**	Cracking Pressure	Seal
B 40 L/min.	X Non-adjustable	A 0,3 bar	N Buna-N
D 80 L/min.		B 1,0 bar	V Viton
F 160 L/min.		C 2,0 bar	
H 320 L/min.		D 3,5 bar	
J 640 L/min.		E 5,0 bar	
		F 7,0 bar	

** See page 162 for information on Control Options

Visit www.sunhydraulics.com for detailed and complete technical information on our full line of products.

FREE FLOW SIDE TO NOSE

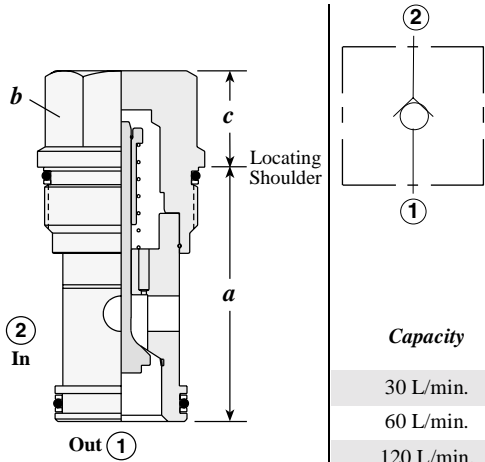

Capacity	Typical Cartridge Model Code	Cavity	Cartridge Dimensions			Installation Torque (Nm)
			a	b	c	
30 L/min.	CXAD – XCN	T - 162A	31	19,1	21	35/40
60 L/min.	CXCD – XCN	T - 13A	34,9	22,2	19	40/50
120 L/min.	CXED – XCN	T - 5A	41,1	28,6	18	60/70
240 L/min.	CXGD – XCN	T - 16A	61,9	31,8	25	200/215
480 L/min.	CXID – XCN	T - 18A	79,4	41,3	31	465/500

Performance Curves

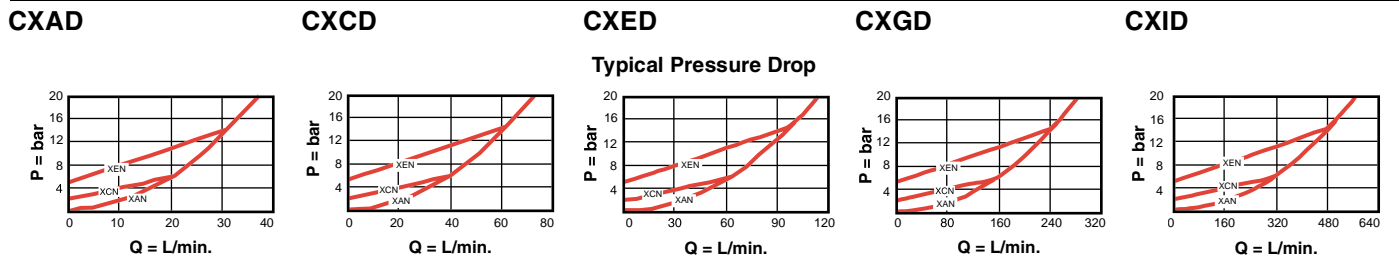

- Maximum operating pressure = 350 bar
- Maximum valve leakage = 0,07 cc/min.
- Will accept 350 bar at ports 1 and 2.
- CXAD only available with 0,3, 2 and 5 bar cracking pressures.

CX * D - * * *

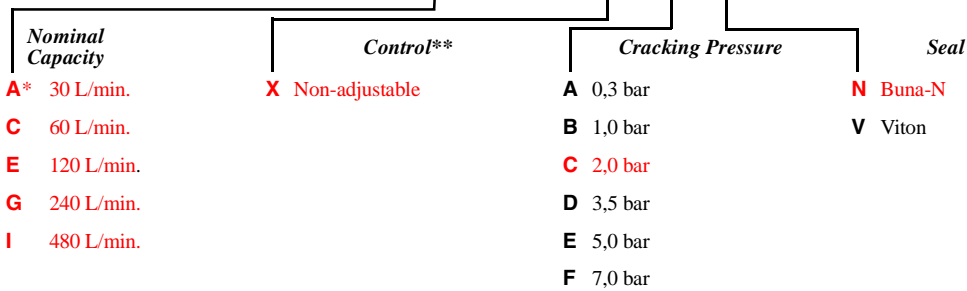

** See page 162 for information on Control Options

* CXAD available with A, C, E Cracking Pressures Only.

Visit www.sunhydraulics.com for detailed and complete technical information on our full line of products.

FREE FLOW SIDE TO NOSE, PORT 3 BLOCKED

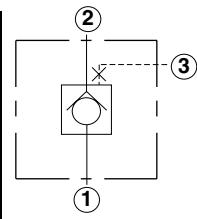
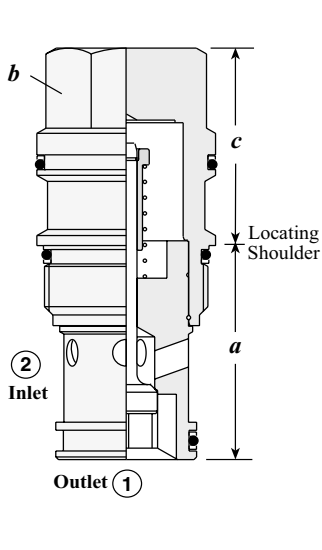

Capacity	Typical Cartridge Model Code	Cavity	Cartridge Dimensions			Installation Torque (Nm)
			a	b	c	
60 L/min.	CXCE – XCN	T - 11A	34,9	22,2	31	40/50
120 L/min.	CXEE – XCN	T - 2A	34,9	28,6	35	60/70
240 L/min.	CXGE – XCN	T - 17A	46	31,8	46	200/215
480 L/min.	CXIE – XCN	T - 19A	63,5	41,3	59	465/500

Performance Curves

CXCE

CXEE

CXGE

CXIE

Typical Pressure Drop

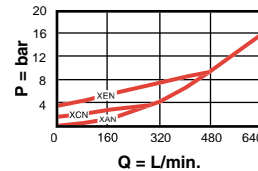
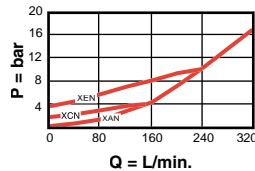
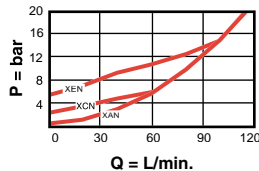
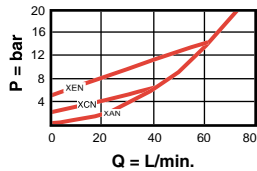

- Maximum operating pressure = 350 bar
- Maximum valve leakage = 0,07 cc/min.
- Will accept 350 bar at ports 1 and 2.

CX * E - * * *

Nominal Capacity	Control**	Cracking Pressure	Seal
C 60 L/min.	X Non-adjustable	A 0,3 bar	N Buna-N
E 120 L/min.		B 1,0 bar	V Viton
G 240 L/min.		C 2,0 bar	
I 480 L/min.		D 3,5 bar	
		E 5,0 bar	
		F 7,0 bar	

** See page 162 for information on Control Options

Visit www.sunhydraulics.com for detailed and complete technical information on our full line of products.

FREE FLOW NOSE TO SIDE WITH BYPASS ORIFICE

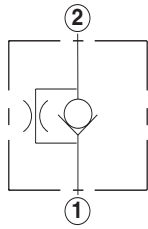
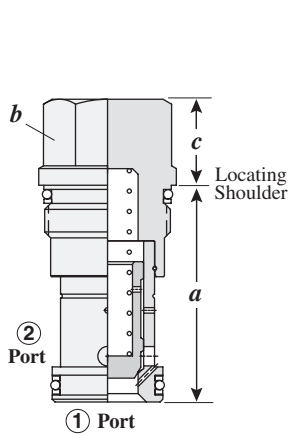

Capacity	Typical Cartridge Model Code	Cavity	Cartridge Dimensions			Installation Torque (Nm)
			a	b	c X	
30 L/min.	CNBC – XCN	T - 162A	31,0	19,1	20,8	35/40
60 L/min.	CNDC – XCN	T - 13A	35,1	22,2	19,1	45/50
120 L/min.	CNFC – XCN	T - 5A	41,4	28,6	17,5	60/70
240 L/min.	CNHC – XCN	T - 16A	61,7	31,8	24,6	200/215
480 L/min.	CNJC – XCN	T - 18A	79,5	41,3	30,2	465/500

Performance Curves

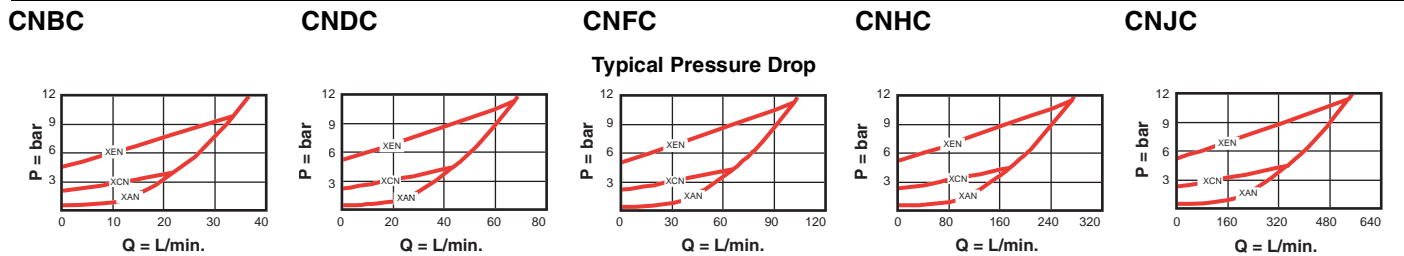

- Maximum operating pressure = 350 bar
- Will accept 350 bar at ports 1 and 2.
- Orifice range = CNBC, CNDC: 0,4 - 1,6 mm, CNFC: 0,4 - 2,0 mm, CNHC: 0,4 - 2,4 mm, CNJC: 0,4 - 3,2 mm.

CN * C - * * *

Nominal Capacity	Control**	Cracking Pressure	Seal
B 30 L/min.	X Non-adjustable	A 0,3 bar	N Buna-N
D 60 L/min.		B 1,0 bar	V Viton
F 120 L/min.		C 2,0 bar	
H 240 L/min.		D 3,5 bar	
J 480 L/min.		E 5,0 bar	
		F 7,0 bar	

**See page 162 for information on Control Options

Customer specified orifice setting range:

- CNBC: 0,4 - 1,6 mm
- CNDC: 0,4 - 1,6 mm
- CNFC: 0,4 - 2,0 mm
- CNHC: 0,4 - 2,4 mm
- CNJC: 0,4 - 3,2 mm

Visit www.sunhydraulics.com for detailed and complete technical information on our full line of products.

Free Flow Check Valves

2 TO 1 FREE FLOW, WITH CUSTOMER SPECIFIED ORIFICE, PORT 3 BLOCKED, 3 PORT CAVITY

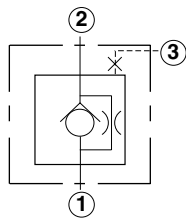
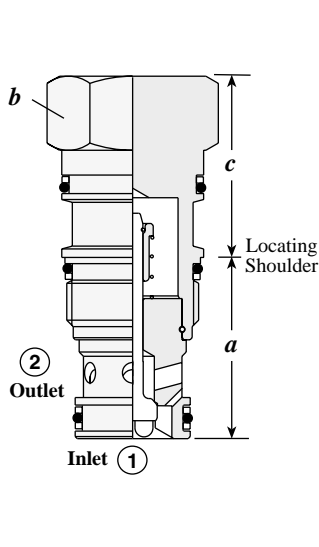

Capacity	Typical Cartridge Model Code	Cavity	Cartridge Dimensions			Installation Torque (Nm)
			a	b	c X	
60 L/min.	CNCD – XCN	T - 11A	34,9	22,2	31	40/50
120 L/min.	CNED – XCN	T - 2A	34,9	28,6	35	60/70
240 L/min.	CNGD – XCN	T - 17A	46	31,8	46	200/215
480 L/min.	CNID – XCN	T - 19A	63,5	41,3	59	465/500

Performance Curves

CNCD

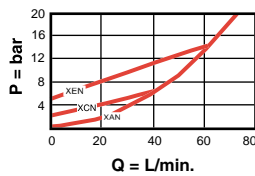

CNED

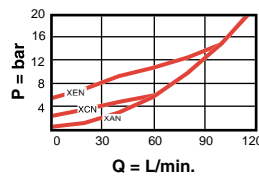

CNGD

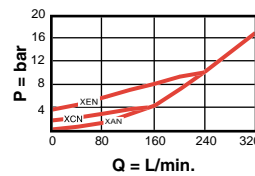

CNID

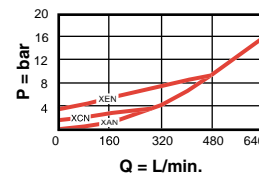

Typical Pressure Drop

- Maximum operating pressure = 350 bar
- Will accept 350 bar at ports 1 and 2
- Orifice range = CNCD: 0,4 - 1,6 mm, CNED: 0,4 - 2,0 mm, CNGD: 0,4 - 2,4 mm, CNID: 0,4 - 3,2 mm

CN ★ D – ★ ★ ★

Nominal Capacity	Control**	Cracking Pressure	Seal
C 60 L/min.	X Non-adjustable	A 0,3 bar	N Buna-N
E 120 L/min.		B 1,0 bar	V Viton
G 240 L/min.		C 2,0 bar	
I 480 L/min.		D 3,5 bar	
		E 5,0 bar	
		F 7,0 bar	



** See page 162 for information on Control Options

Customer specified orifice setting range:

CNCD: 0,4 - 1,6 mm
 CNED: 0,4 - 2,0 mm
 CNGD: 0,4 - 2,4 mm
 CNID: 0,4 - 3,2 mm

Visit www.sunhydraulics.com for detailed and complete technical information on our full line of products.

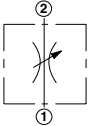
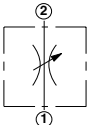
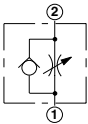
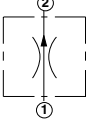
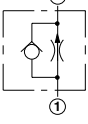
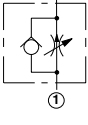
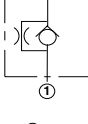
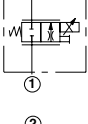
Flow Control Valves

	<i>Cartridge Type</i>	<i>Page</i>
	Fully Adjustable Needle	66
	Fully Adjustable Needle, High Capacity	67
	Fully Adjustable Needle with Reverse Flow Check	68
	Fixed Orifice, Pressure Compensated	69
	Fixed Orifice, Pressure Compensated with Reverse Flow Check	70
	Fully Adjustable Pressure Compensated with Reverse Flow Check	71
	Free Flow Side-to-Nose with Bypass Orifice	72
	Electro-proportional, Normally Closed Throttle	73
	Electro-proportional, Normally Open Throttle	74

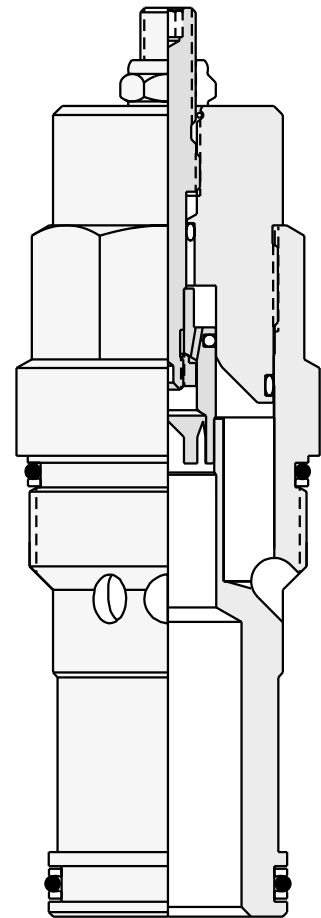

FULLY ADJUSTABLE NEEDLE

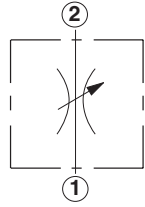
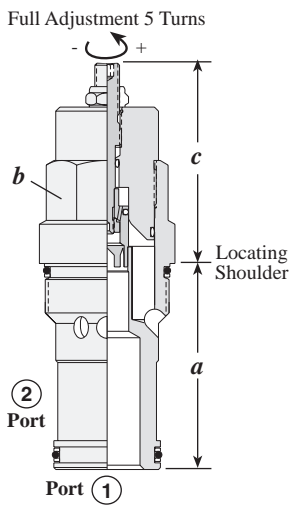

Maximum Nominal Orifice	Typical Cartridge Model Code	Cavity	Cartridge Dimensions					Installation Torque (Nm)
			a	b	c			
4,0 mm dia.	NFBC – LCN	T - 162A	31	19,1	41	-	45	35/40
4,8 mm dia.	NFCC – LCN	T - 13A	34,9	22,2	58	64	64	40/50
6,3 mm dia.	NFDC – LAN	T - 5A	41,1	28,6	67	72	73	60/70
9,6 mm dia.	NFEC – LEN	T - 16A	61,9	31,8	73	79	79	200/215
14,2 mm dia.	NFFC – LGN	T - 18A	79,4	41,3	84	90	90	465/500

Performance Curves

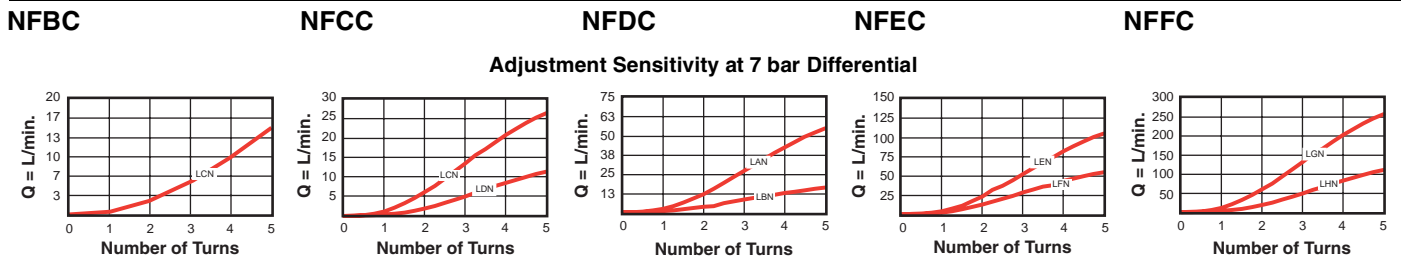

- Maximum operating pressure = 350 bar
- Maximum valve leakage at shutoff = less than 0,4 cc/min.

NF * C - * * *

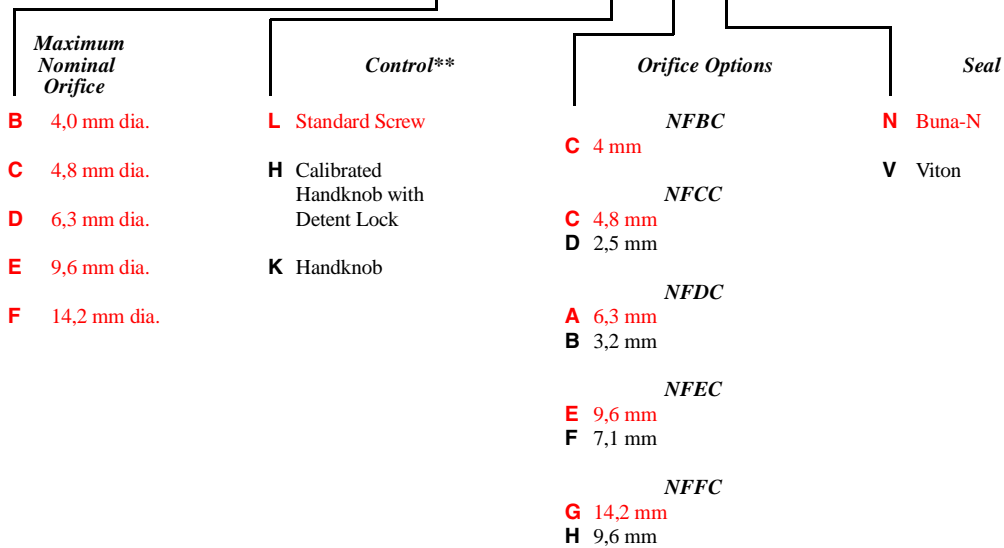

** See page 162 for information on Control Options

Visit www.sunhydraulics.com for detailed and complete technical information on our full line of products.

FULLY ADJUSTABLE NEEDLE, HIGH CAPACITY

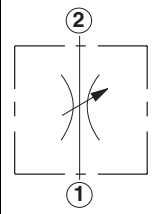
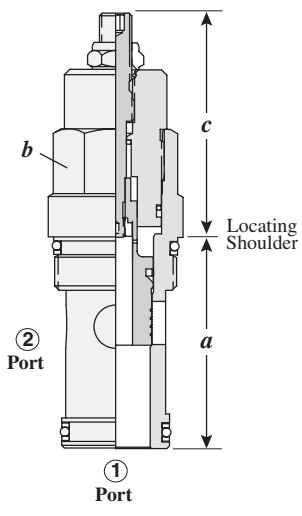

Nominal Orifice	Typical Cartridge Model Code	Cavity	Cartridge Dimensions						Installation Torque (Nm)
			a	b	c				
8,4 mm dia.	NFCD – LFN	T - 13A	34,9	22,2	L	H	K	40/50	
12,7 mm dia.	NFDD – LGN	T - 5A	41,1	28,6	67	72	73	60/70	
17,5 mm dia.	NFED – LHN	T - 16A	61,9	31,8	73	79	79	200/215	
21,6 mm dia.	NFFD – LIN	T - 18A	79,4	41,3	84	90	90	465/500	

Performance Curves

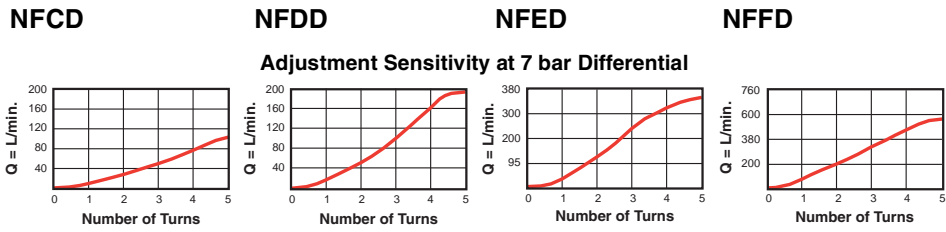

- Maximum operating pressure = 350 bar
- Maximum valve leakage at shutoff = less than 0,4 cc/min.

NF * D - * * *

Nominal Orifice	Control**	Orifice Options	Seal
C 8,4 mm dia.	L Standard Screw	NFCD	N Buna-N
D 12,7 mm dia.	H Calibrated Handknob with Detent Lock	F 8,4 mm	V Viton
E 17,5 mm dia.		G 12,7 mm	
F 21,6 mm dia.	K Handknob	H 17,5 mm	
		I 21,6 mm	

** See page 162 for information on Control Options

Visit www.sunhydraulics.com for detailed and complete technical information on our full line of products.

FULLY ADJUSTABLE NEEDLE WITH REVERSE FLOW CHECK

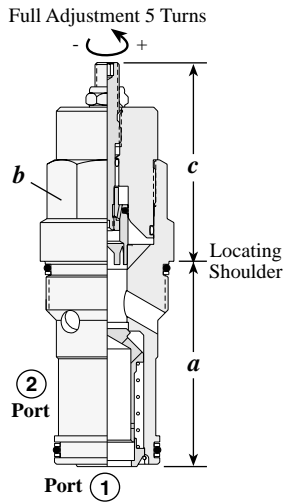

Maximum Nominnal Orifice	Typical Cartridge Model Code	Cavity	Cartridge Dimensions					Installation Torque (Nm)
			a	b	c			
					L	H	K	
4,0 mm dia.	NCBB – LCN	T - 162A	31	19,1	41	-	45	35/40
4,8 mm dia.	NCCB – LCN	T - 13A	34,9	22,2	58	64	64	40/50
6,3 mm dia.	NCEB – LCN	T - 5A	41,1	28,6	67	72	73	60/70
9,6 mm dia.	NCFB – LCN	T - 16A	61,9	31,8	73	79	79	200/215
14,2 mm dia.	NCGB – LCN	T - 18A	79,4	41,3	84	90	90	465/500

Performance Curves

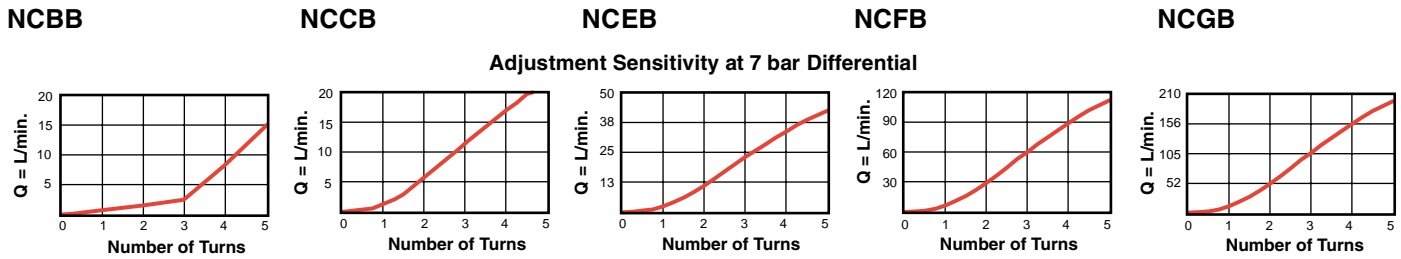

- Maximum operating pressure = 350 bar
- Maximum valve leakage = 0,4 cc/min.

NC ★ ★ - ★ **C** ★

Maximum Nominnal Orifice	Version	Control**	Cracking Pressure*	Seal
NCBB* 4,0 mm dia.	B High Capacity	L Standard Screw	A 0,3 bar	N Buna-N
NCCB 4,8 mm dia. NCCC 2,3 mm dia.	C Low Capacity	H Calibrated Handknob with Detent Lock	C 2,0 bar	V Viton
NCEB 6,3 mm dia. NCEC 3,2 mm dia.		K Handknob	E 5,0 bar	
NCFB 9,6 mm dia. NCFC 7,1 mm dia.				
NCGB 14,2 mm dia. NCGC 9,6 mm dia.				

** See page 162 for information on Control Options

*Cracking Pressure Ranges: A and E ranges are not available in T-162A cavity.

Visit www.sunhydraulics.com for detailed and complete technical information on our full line of products.

FIXED ORIFICE, PRESSURE COMPENSATED

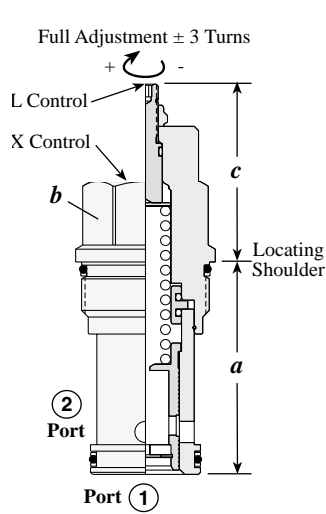

Nominal Capacity	Typical Cartridge Model Code	Cavity	Cartridge Dimensions					Installation Torque (Nm)
			a	b	c			
0,4-12 L/min.	FXBA - XAN	T - 162A	31	19,1	21	54	58	35/40
0,4-25 L/min.	FXCA - XAN	T - 13A	34,9	22,2	19	51	58	40/50
0,4-50 L/min.	FXDA - XAN	T - 5A	41,1	28,6	18	54	61	60/70
0,8-100 L/min.	FXEA - XAN	T - 16A	61,9	31,8	25	62	69	200/215
0,8-200 L/min.	FXFA - XAN	T - 18A	79,4	41,3	31	72	78	465/500

Performance Curves

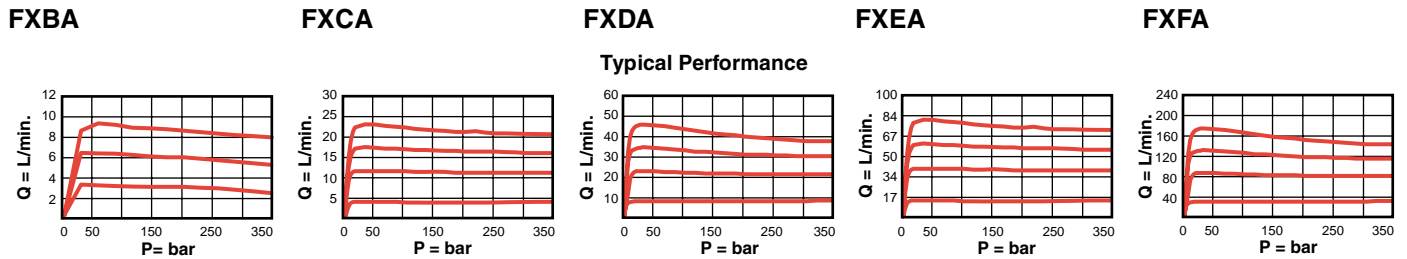

- Maximum operating pressure = 350 bar
- Customer must specify flow setting
- Accurate pressure compensated control requires that a 14 bar minimum pressure differential be maintained across the valve.
- The tuneable control option provides +/- 25% variation from the nominal factory pre-set flow.

FX ★ A - ★ A ★

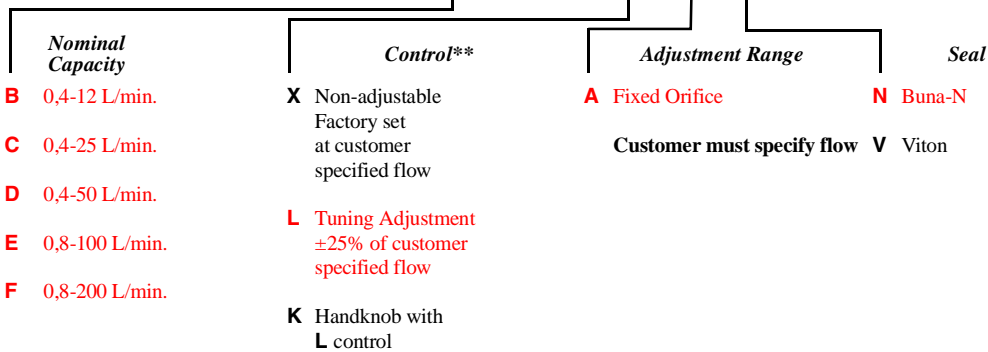

** See page 162 for information on Control Options

Visit www.sunhydraulics.com for detailed and complete technical information on our full line of products.

FIXED ORIFICE, PRESSURE COMPENSATED WITH REVERSE FLOW CHECK

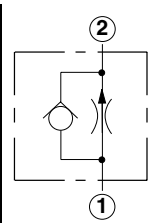
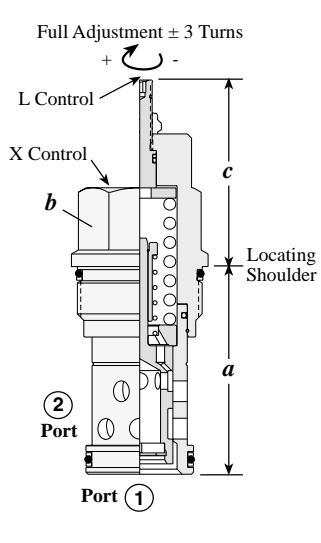

Nominal Capacity	Typical Cartridge Model Code	Cavity	Cartridge Dimensions					Installation Torque (Nm)
			a	b	X	L	K	
0,4-12 L/min.	FCBB – XAN	T - 162A	31	19,1	21	54	58	35/40
0,4-25 L/min.	FCCB – XAN	T - 13A	34,9	22,2	19	51	58	40/50
0,4-50 L/min.	FCDB – XAN	T - 5A	41,1	28,6	18	54	61	60/70
0,8-100 L/min.	FCEB – XAN	T - 16A	61,9	31,8	25	62	69	200/215
0,8-200 L/min.	FCFB – XAN	T - 18A	79,4	41,3	31	72	78	465/500

Performance Curves

FCBB

FCCB

FCDB

FCEB

FCFB

Reverse Free Flow Pressure Drop Based on Specified Flow Extremes

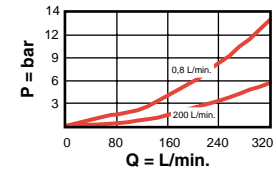
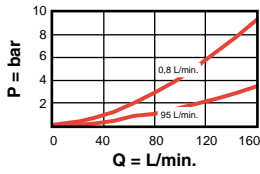
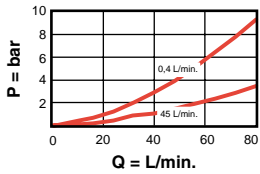
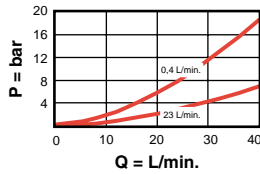
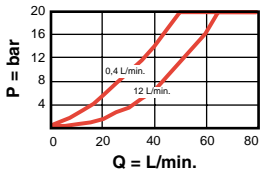

- Maximum operating pressure = 350 bar
- Customer must specify flow setting
- Accurate pressure compensated control requires that a 14 bar minimum pressure differential be maintained across the valve.
- The tuneable control option provides +/- 25% variation from the nominal factory pre-set flow.

FC ★ B – ★ A ★

Nominal Capacity	Control**	Adjustment Range	Seal
B 0,4-12 L/min.	X Non-adjustable Factory set at customer specified flow	A Fixed Orifice	N Buna-N
C 0,4-25 L/min.	L Tuning Adjustment $\pm 25\%$ of customer specified flow	Customer must specify flow	V Viton
D 0,4-50 L/min.			
E 0,8-100 L/min.	K Handknob with L control		
F 0,8-200 L/min.			

** See page 162 for information on Control Options

Visit www.sunhydraulics.com for detailed and complete technical information on our full line of products.

FULLY ADJUSTABLE, PRESSURE COMPENSATED WITH REVERSE FLOW CHECK

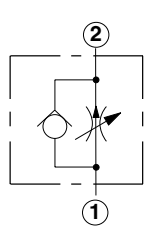
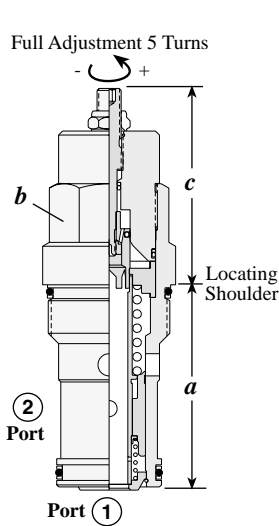

Nominal Flow Range	Typical Cartridge Model Code	Cavity	Cartridge Dimensions					Installation Torque (Nm)
			a	b	c			
					L	H	K	
0,4-23 L/min.	FDBA - LAN	T - 13A	34,9	22,2	58	64	64	40/50
0,4-45 L/min.	FDCB - LAN	T - 5A	41,1	28,6	67	72	73	60/70
1-95 L/min.	FDEA - LAN	T - 16A	61,9	31,8	73	79	79	200/215
1-200 L/min.	FDFA - LAN	T - 18A	79,4	41,3	84	90	90	465/500

Performance Curves

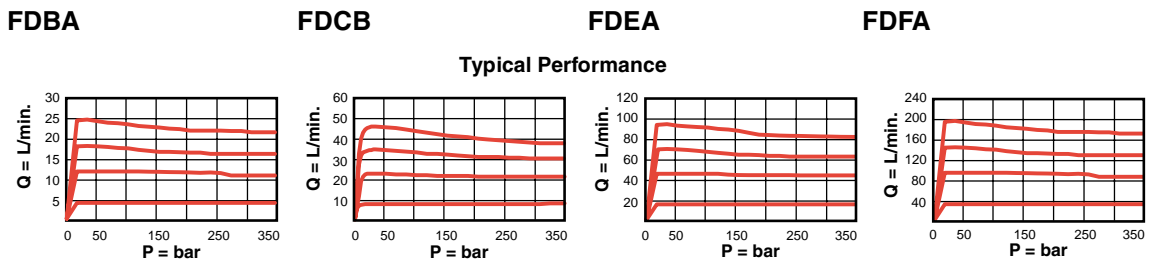

- Maximum operating pressure = 350 bar
- Accurate pressure compensated control requires that a 14 bar minimum pressure differential be maintained across the valve.

FD * * - * A *

Nominal Flow Range	Control**	Adjustment Range	Seal
BA 0,4-23 L/min.	L Standard Screw	FDBA	N Buna-N
CB 0,4-45 L/min.	H Calibrated Handknob with Detent Lock	A 0,4 - 23 L/min.	V Viton
EA 1-95 L/min.	K Handknob	FDCB	
FA 1-200 L/min.		A 0,4 - 45 L/min.	
		FDEA	
		A 1 - 95 L/min.	
		FDFA	
		A 1 - 200 L/min.	

** See page 162 for information on Control Options

Visit www.sunhydraulics.com for detailed and complete technical information on our full line of products.

FREE FLOW SIDE-TO-NOSE WITH BYPASS ORIFICE

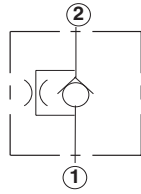
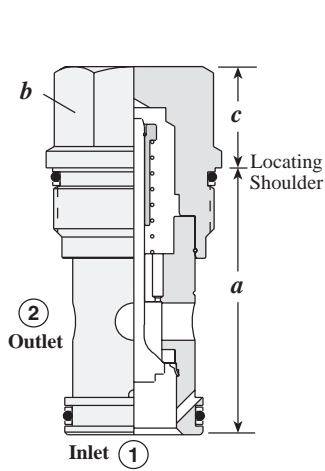

Nominal Capacity	Typical Cartridge Model Code	Cavity	Cartridge Dimensions			Installation Torque (Nm)
			a	b	c X	
30 L/min.	CNAC – XCN	T - 162A	31	19,1	21	35/40
60 L/min.	CNCC – XCN	T - 13A	34,9	22,2	19	40/50
120 L/min.	CNEC – XCN	T - 5A	41,1	28,6	18	60/70
240 L/min.	CNGC – XCN	T - 16A	61,9	31,8	25	200/215
480 L/min.	CNIC – XCN	T - 18A	79,4	41,3	31	465/500

Performance Curves

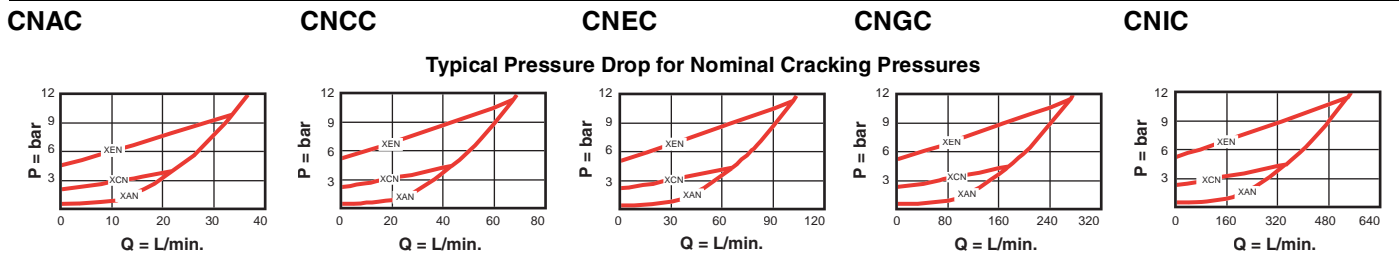

- Maximum operating pressure = 350 bar
- Will accept 350 bar at ports 1 and 2.
- * Orifice range = CNAC, CNCC: 0,4 - 1,6 mm, CNEC: 0,4 - 2,0 mm, CNGC: 0,4 - 2,4 mm, CNIC: 0,4 - 3,2 mm.

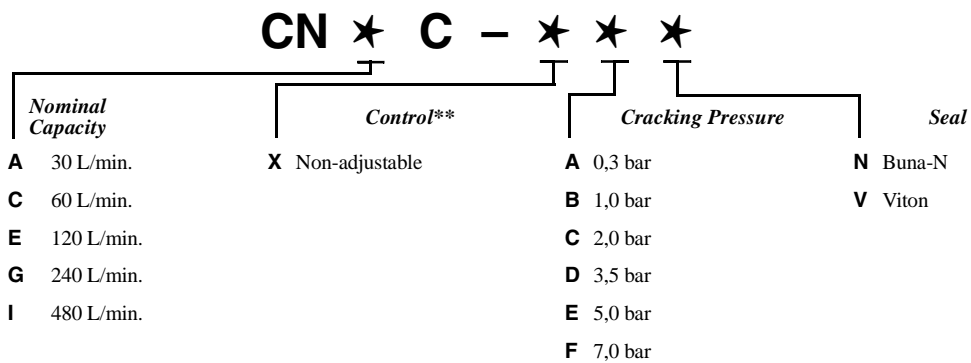

* Customer specified orifice setting range:
 CNAC: 0,4 - 1,6 mm
 CNCC: 0,4 - 1,6 mm
 CNEC: 0,4 - 2,0 mm
 CNGC: 0,4 - 2,4 mm
 CNIC: 0,4 - 3,2 mm

** See page 162 for information on Control Options

Visit www.sunhydraulics.com for detailed and complete technical information on our full line of products.

ELECTRO-PROPORTIONAL, NORMALLY CLOSED THROTTLE

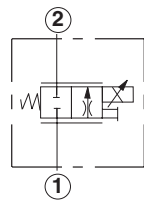
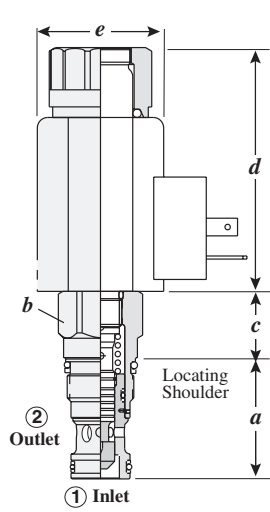

Maximum Nominal Capacity	Typical Cartridge Model Code	Cavity	Cartridge Dimensions					Installation Torque (Nm)
			a	b	c	d	e	
28 L/min.	FPCC – MCN	T - 13A	35,1	22,2	19,1	70,1	37,3	40/50

Performance Curves

FPCC

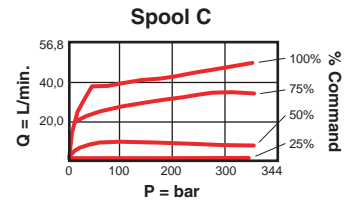
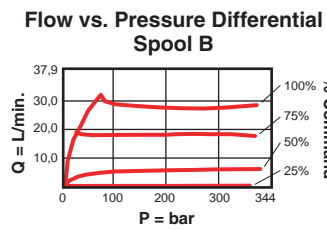
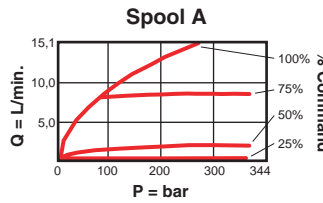
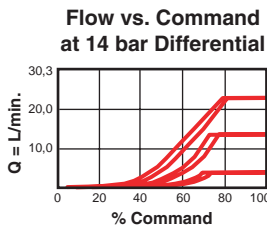

- Maximum operating pressure = 350 bar
- Maximum valve leakage = 100 cc/min. at 210 bar
- For optimum performance, an amplifier with current sensing and adjustable dither should be used. Dither should be adjustable between 100 - 250 Hz.

FP C C - * * *

Maximum Nominal Capacity	Control**	Nominal Capacity	Seal
C 28 L/min.	M Manual Override (Standard)	A 6 L/min. B 14 L/min. C 28 L/min.	N Buna-N V Viton

NOTE: Coil must be ordered separately. Use 12V DC or 24V DC (Series 770-*) coils only. See page 167.**

** See page 162 for information on Control Options

Visit www.sunhydraulics.com for detailed and complete technical information on our full line of products.



ELECTRO-PROPORTIONAL, NORMALLY OPEN THROTTLE

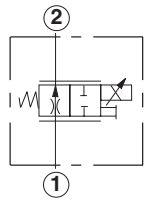
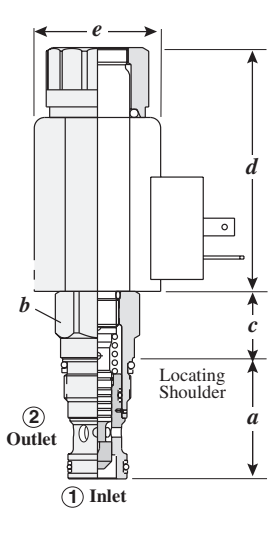

Maximum Nominal Capacity	Typical Cartridge Model Code	Cavity	Cartridge Dimensions					Installation Torque (Nm)
			a	b	c	d	e	
28 L/min.	FPCH – MCN	T - 13A	35,1	22,2	19,1	70,1	1,47	40/50

Performance Curves

FPCH

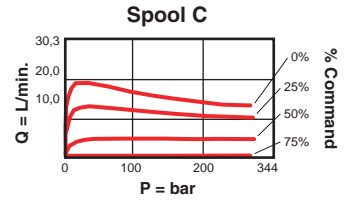
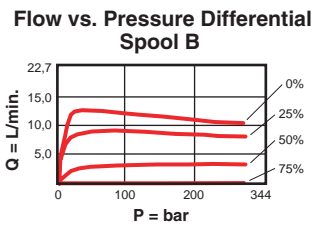
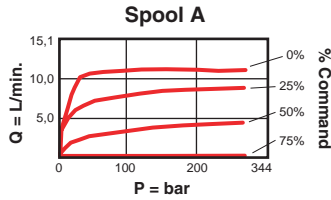
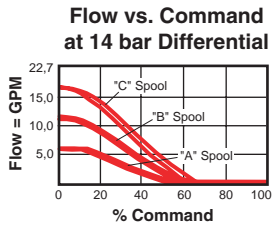

- Maximum operating pressure = 350 bar
- Maximum valve leakage = 100 cc/min. at 210 bar
- For optimum performance, an amplifier with current sensing and adjustable dither should be used. Dither should be adjustable between 100 - 250 Hz.

FPCH – ★★

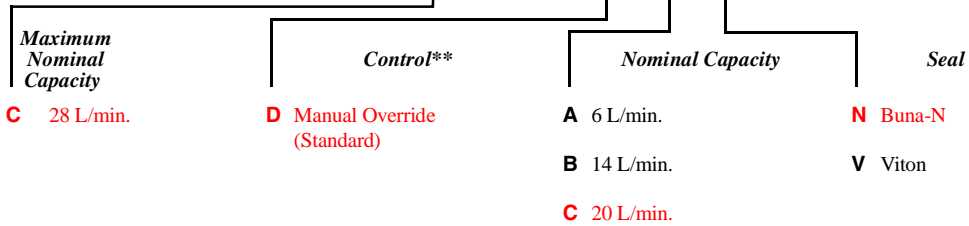

** See page 162 for information on Control Options

Visit www.sunhydraulics.com for detailed and complete technical information on our full line of products.

Priority Flow Control Cartridge Valves

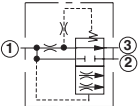
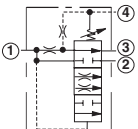
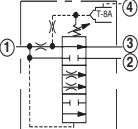
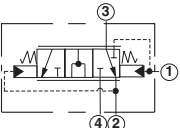
	<i>Cartridge Type</i>	<i>Page</i>
	Bypass / Restrictive, Fixed Orifice	76
	Ventable, Bypass / Restrictive, Fixed Orifice	77
	Ventable, Bypass / Restrictive, Fixed Orifice with Integral Pilot Control Cavity	78
	Bypass / Restrictive Modulating Element	79

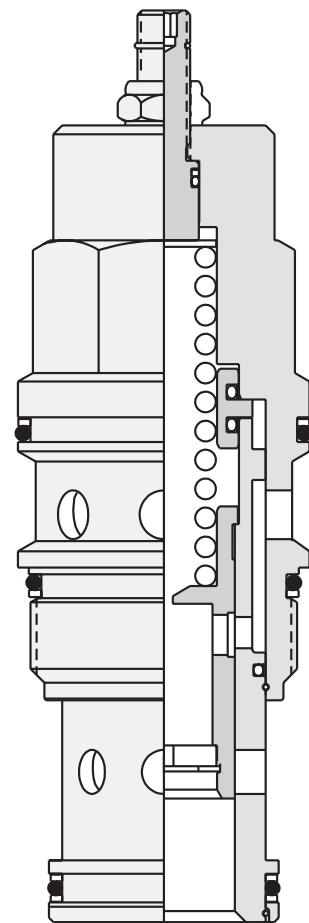

BYPASS / RESTRICTIVE, FIXED ORIFICE

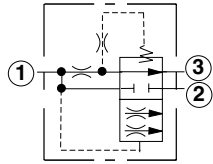
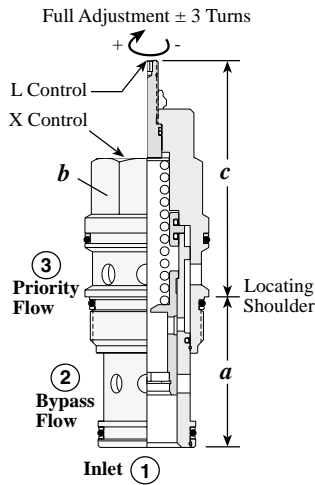

Capacity	Typical Cartridge Model Code	Cavity	Cartridge Dimensions					Installation Torque (Nm)
			a	b	X	L	K	
0,4-12 L/min.	FRBA – XAN	T - 163A	31	19,1	32	43	47	35/40
0,4-25 L/min.	FRCA – XAN	T - 11A	34,9	22,2	31	64	71	40/50
0,4-50 L/min.	FRDA – XAN	T - 2A	34,9	28,6	35	72	78	60/70
0,8-100 L/min.	FREA – XAN	T - 17A	46	31,8	46	84	91	200/215
0,8-200 L/min.	FRFA – XAN	T - 19A	63,5	41,3	60	100	107	465/500

Performance Curves

FRBA

FRCA

FRDA

FREA

FRFA

Typical Performance

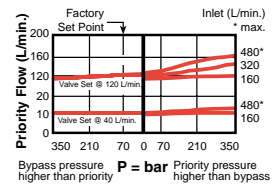
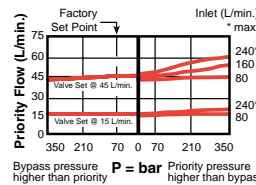
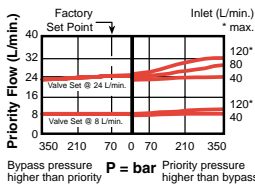
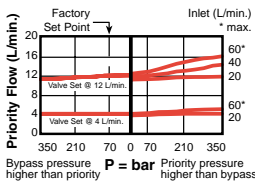
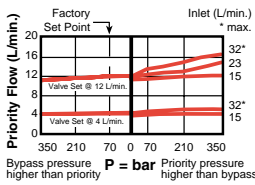

- Maximum operating pressure = 350 bar
- Customer must specify a flow rating. Factory set flow ratings are within +/- 10% of the requested setting.
- Pressure at the bypass port (port 2) may exceed pressure at the priority port (port 3).
- Maximum pressure at port 3 should be limited to 210 bar.
- Both priority and bypass flow are usable up to the system operating pressure.
- Bypass flow is not available until priority flow requirements are satisfied.
- Blocking priority flow will also block bypass flow.

FR * A - * A *

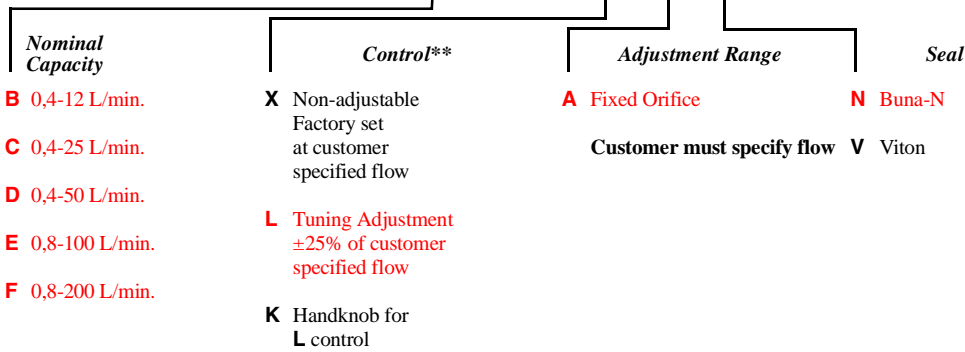

Maximum Inlet Flow:
 FRBA: 30 L/min.
 FRCA: 60 L/min.
 FRDA: 120 L/min.
 FREA: 240 L/min.
 FRFA: 480 L/min.

** See page 162 for information on Control Options

Priority Flow ranges:
 FRBA: 0,4 - 12 L/min.
 FRCA: 0,4 - 25 L/min.
 FRDA: 0,4 - 50 L/min.
 FREA: 0,8 - 100 L/min.
 FRFA: 0,8 - 200 L/min.

Visit www.sunhydraulics.com for detailed and complete technical information on our full line of products.

VENTABLE, BYPASS / RESTRICTIVE, FIXED ORIFICE

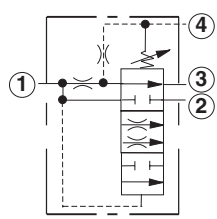
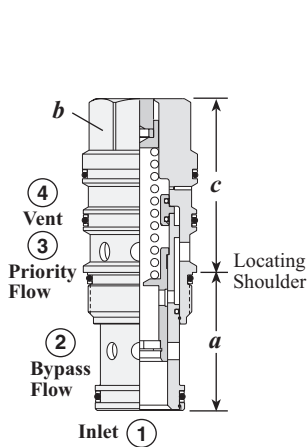

Capacity	Typical Cartridge Model Code	Cavity	Cartridge Dimensions					Installation Torque (Nm)
			a	b	c			
0,4-25 L/min.	FVCA – XAN	T - 21A	34,9	22,2	X	L	K	40/50
0,4-50 L/min.	FVDA – XAN	T - 22A	34,9	28,6	51	88	94	60/70
0,8-100 L/min.	FVEA – XAN	T - 23A	46	31,8	66	100	107	200/215
0,8-200 L/min.	FVFA – XAN	T - 24A	63,5	41,3	81	121	128	465/500

Performance Curves

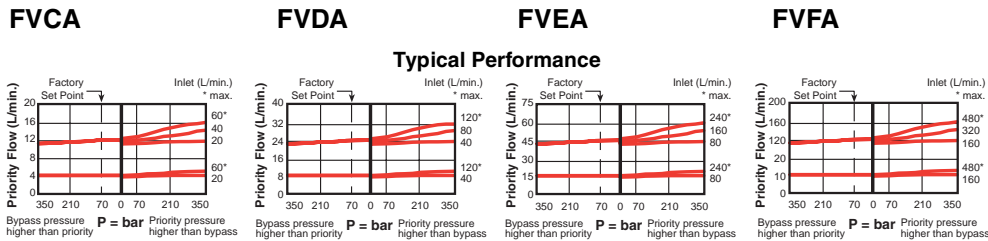

- Maximum operating pressure = 350 bar
- Nominal vent flow = 0,75 L/min.
- Pressure at the bypass (port 2) may exceed pressure at the priority port (port 3).
- Maximum pressure at port 3 should be limited to 210 bar.
- Both priority and bypass flow are usable up to the system operating pressure.
- Bypass flow is not available until priority flow requirements are satisfied, except when the valve is vented. When port 4 (vent) is open, all flow diverts to port 2 if pressure at port 1 (inlet) is 10,5 bar or higher.
- Using a pressure control on port 4 will limit the pressure at the priority port (port 3). If pressure on the bypass port (port 2) exceeds the setting of the pressure control, priority flow will be shut off and all the flow will go out the bypass port.
- Blocking priority flow will also block bypass flow.

FV ★ A – ★ A ★

Nominal Capacity	Control**	Adjustment Range	Seal
C 0,4-25 L/min.	X Non-adjustable factory set at customer specified flow	A Fixed Orifice	N Buna-N
D 0,4-50 L/min.	L Tuning Adjustment ±25% of customer specified flow	Customer must specify flow	V Viton
E 0,8-100 L/min.	K Handknob (includes L controls)		
F 0,8-200 L/min.			

Maximum Inlet Flow:
 FVCA: 60 L/min.
 FVDA: 120 L/min.
 FVEA: 240 L/min.
 FVFA: 480 L/min.

Priority Flow ranges:
 FVCA: 0,4 - 25 L/min.
 FVDA: 0,4 - 50 L/min.
 FVEA: 0,8 - 100 L/min.
 FVFA: 0,8 - 200 L/min.

**See page 162 for information on Control Options

Visit www.sunhydraulics.com for detailed and complete technical information on our full line of products.



VENTABLE, BYPASS / RESTRICTIVE, FIXED ORIFICE WITH INTEGRAL PILOT CONTROL CAVITY

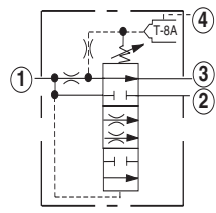
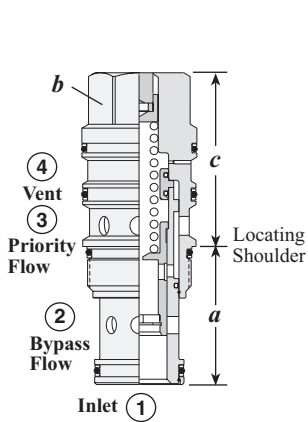

The -8 control option allows the pilot control valve to be incorporated directly into the end of the priority flow control cartridge via the T-8A cavity. These pilot control cartridges are sold separately and include electro-proportional, solenoid, air pilot, and hydraulic pilot operation. See Pilot Control Cartridges on page 121.

Capacity	Typical Cartridge Model Code	Cavity	Cartridge Dimensions			Installation Torque (Nm)
			a	b	c	
0,4-25 L/min.	FVCA - 8AN	T - 21A	34,9	22,2	46	40/50
0,4-50 L/min.	FVDA - 8AN	T - 22A	34,9	28,6	46	40/50
0,8-100 L/min.	FVEA - 8AN	T - 23A	46	31,8	46	40/50
0,8-200 L/min.	FVFA - 8AN	T - 24A	63.5	41,3	46	40/50

Performance Curves

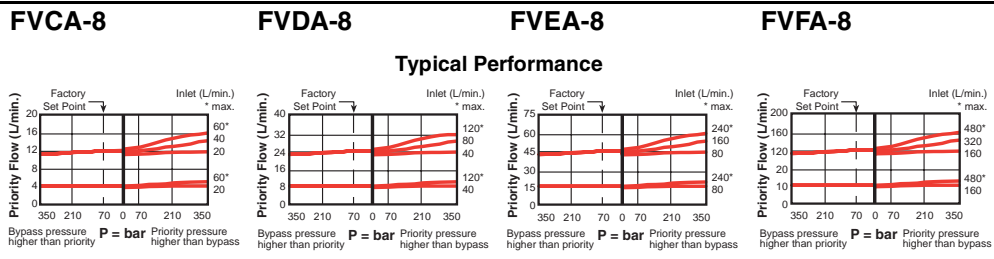

- Maximum operating pressure = 350 bar
- Nominal vent flow = 0,75 L/min.
- Pressure at the bypass port (port 2) may exceed pressure at the priority port (port 3).
- Maximum pressure at port 3 should be limited to 210 bar.
- Both priority and bypass flow are usable up to the system operating pressure.
- Bypass flow is not available until priority flow requirements are satisfied, except when the valve is vented. When port 4 (vent) is open, all flow diverts to port 2 if pressure at port 1 (inlet) is 10,5 bar or higher.
- Using a pressure control on port 4 will limit the pressure at the priority port (port 3). If pressure on the bypass port (port 2) exceeds the setting of the pressure control, priority flow will be shut off and all the flow will go out the bypass port.
- Blocking priority flow will also block bypass flow.
- The main stage valve should first be installed to the correct torque value followed by the T-8A pilot control section into the main stage valve to its required torque value.

FV ★ A - 8 A ★

Nominal Capacity	Control**	Adjustment Range	Seal
C 0,4-25 L/min.	8 T-8A cavity in hex body for pilot operation (Pilot valve to be ordered separately)	A Fixed Orifice	N Buna-N
D 0,4-50 L/min.		Customer must specify flow	
E 0,8-100 L/min.			V Viton
F 0,8-200 L/min.			

Maximum Inlet Flow:
 FVCA: 60 L/min.
 FVDA: 120 L/min.
 FVEA: 240 L/min.
 FVFA: 480 L/min.

**See page 162 for information on Control Options

Priority Flow ranges:
 FVCA: 0,4 - 25 L/min.
 FVDA: 0,4 - 50 L/min.
 FVEA: 0,8 - 100 L/min.
 FVFA: 0,8 - 200 L/min.

Visit www.sunhydraulics.com for detailed and complete technical information on our full line of products.

BYPASS / RESTRICTIVE MODULATING ELEMENT

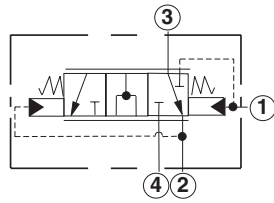
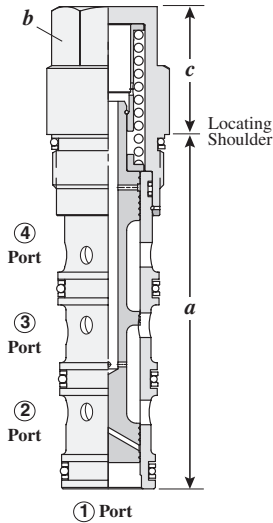

Capacity	Typical Cartridge Model Code	Cavity	Cartridge Dimensions			Installation Torque (Nm)
			a	b	c X	
60 L/min.	LHDA – XFN	T - 31A	84,8	22,2	30	40/50
120 L/min.	LHFA – XFN	T - 32A	92,2	28,6	34	60/70
240 L/min.	LHHA – XFN	T - 33A	114,4	31,8	42	200/215
480 L/min.	LHJA – XFN	T - 34A	139,7	41,3	51	465/500

- Maximum operating pressure = 350 bar
- Bypass flow is not available until priority flow requirements are satisfied.
- Bypass pressure at port 4 can be higher than pressure at control port 2.
- Priority flow can be turned on or off with a pilot sized solenoid valve on port 1.

LH * A - X * *

Maximum Inlet Flow	Control**	Adjustment Range	Seal
D 60 L/min.	X Non-adjustable	E 5 - 7 bar	N Buna-N
F 120 L/min.		F 7 - 9,5 bar	V Viton
H 240 L/min.			
J 480 L/min.			

** See page 162 for information on Control Options

Visit www.sunhydraulics.com for detailed and complete technical information on our full line of products.

NOTES

Flow Divider / Combiner Cartridge Valves

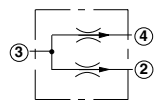
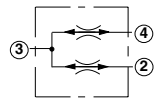
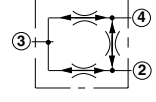
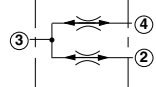
	<i>Cartridge Type</i>
	Divider
	Divider / Combiner, Closed Centre
	Synchronizing Divider / Combiner
	High Capacity Divider / Combiner, Closed Center

<i>Page</i>
82
83
84
85

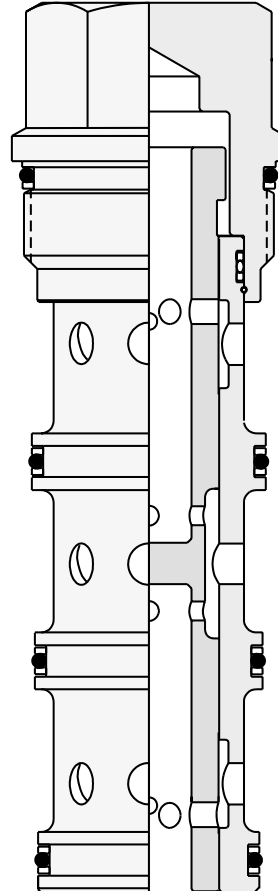

DIVIDER

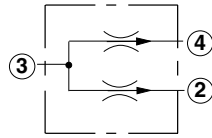
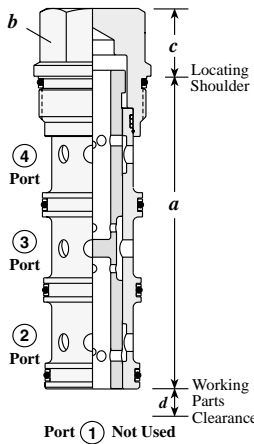

Capacity Min/Max	Typical Cartridge Model Code	Cavity	Cartridge Dimensions				Installation Torque (Nm)
			a	b	c	d	
2,5-12 L/min.	FSBD – XAN	T - 31A	84,8	22,2	19	17	40/50
6-30 L/min.	FSCD – XAN	T - 31A	84,8	22,2	19	17	40/50
12-60 L/min.	FSDD – XAN	T - 32A	92,2	28,6	18	20	60/70
23-120 L/min.	FSED – XAN	T - 33A	114,4	31,8	25	26	200/215
45-240 L/min.	FSFD – XAN	T - 34A	139,7	41,3	31	30	465/500

Performance Curves

Operating Characteristics

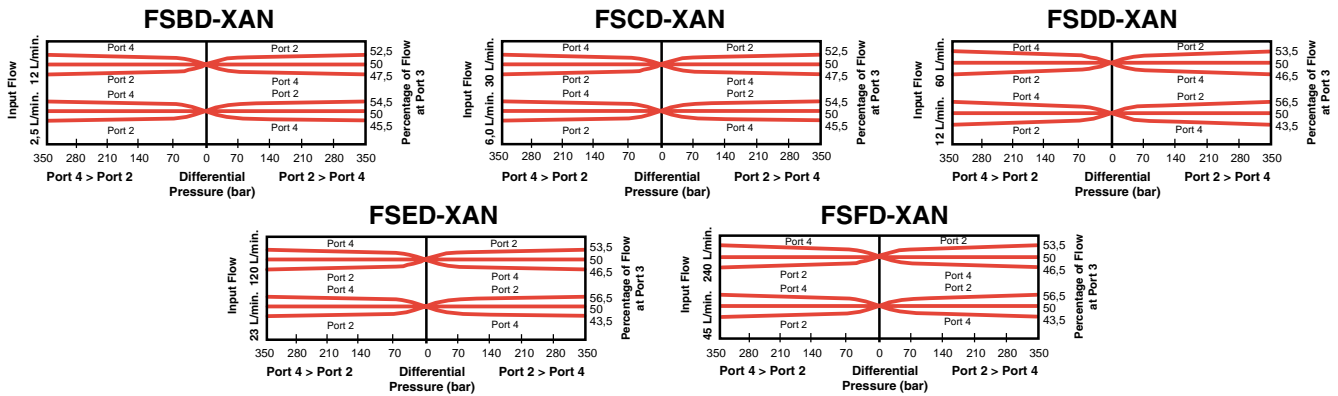

- Maximum operating pressure = 350 bar
- This valve is a divider only; any attempt to flow backwards through the valve is not advised.
- Divisional accuracy at maximum rated input flow = FSBD: $\pm 2.5\%$, FSCD, FSDD, FSED, FSFD: $\pm 3.5\%$
- Divisional accuracy at minimum rated input flow = FSBD: $\pm 4.5\%$, FSCD, FSDD, FSED, FSFD: $\pm 6.5\%$
- Pressure drop at maximum input flow = 18 bar
- Pressure drop at minimum input flow = 0,7 bar
- Below the minimum flow rating there is not enough flow for the valve to modulate. It is effectively a tee. If flow starts at zero and rises, there will be no dividing control until the flow reaches the minimum rating.

FS * D – X * *

Nominal Capacity	Control	Flow Proportion	Seal
B 2,5-12 L/min.	X Non-adjustable	A 50/50 Flow Split	N Buna-N
C 6-30 L/min.		B *40/60 Flow Split	V Viton
D 12-60 L/min.		C *33/67 Flow Split	
E 23-120 L/min.			
F 45-240 L/min.			

* Port 4 is always high percentage flow.

Reverse Flow Path is unpredictable
 Divisional Accuracy =
 FSCD, FSDD, FSED and FSFD:
 $\pm 6.5\%$ at minimum input flow
 $\pm 3.5\%$ at maximum input flow
 FSBD:
 $\pm 4.5\%$ at minimum input flow
 $\pm 2.5\%$ at maximum input flow

Visit www.sunhydraulics.com for detailed and complete technical information on our full line of products.

DIVIDER / COMBINER, CLOSED CENTER

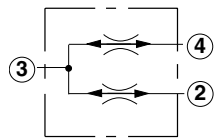
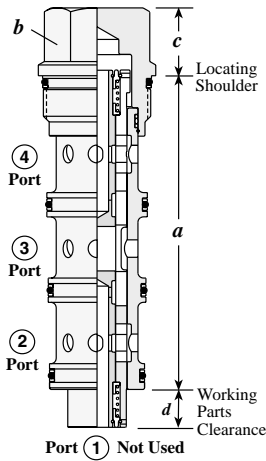

Note: Closed center valves have spring centered internal spools that provide blocked flow paths when centered. Centering occurs when the Port 3 flow is also blocked. This internal blocking isolates Port 2 and 4 from cross flow.

Capacity Min/Max	Typical Cartridge Model Code	Cavity	Cartridge Dimensions				Installation Torque (Nm)
			a	b	c	d	
2,5-12 L/min.	FSBA - XAN	T - 31A	84,8	22,2	19	17	40/50
6-30 L/min.	FSCA - XAN	T - 31A	84,8	22,2	19	17	40/50
12-60 L/min.	FSDA - XAN	T - 32A	92,2	28,6	18	20	60/70
23-120 L/min.	FSEA - XAN	T - 33A	114,4	31,8	25	26	200/215
45-240 L/min.	FSFA - XAN	T - 34A	139,7	41,3	31	30	465/500

Performance Curves

Operating Characteristics

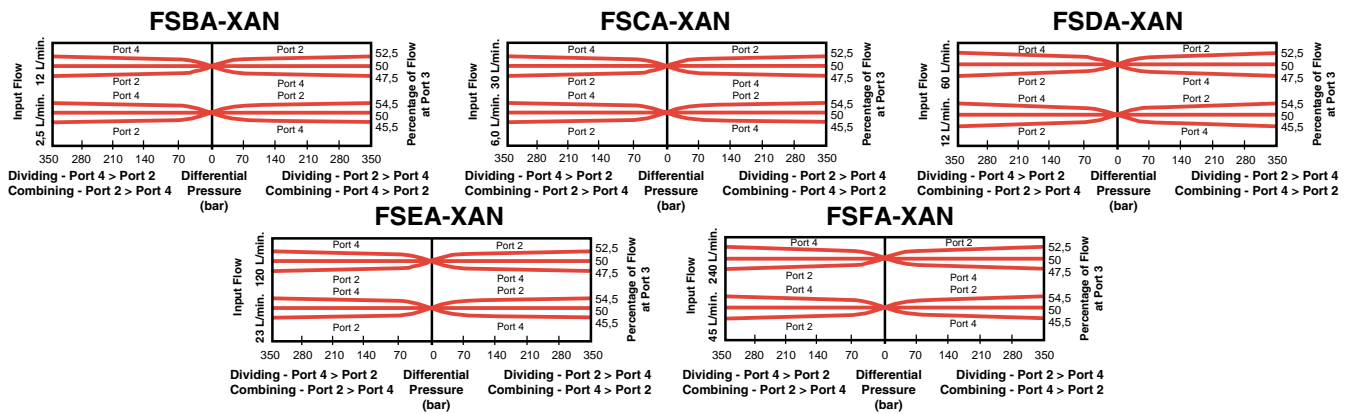

- Maximum operating pressure = 350 bar
- Divisional accuracy at rated maximum input flow = 50% ±2.5%
- Divisional accuracy at rated minimum input flow = 50% ±4.5%
- Pressure drop at maximum input flow = 24 bar
- Pressure drop at minimum input flow = 1,7 bar
- Below the minimum flow rating there is not enough flow for the valve to modulate. It is effectively a tee. If flow starts at zero and rises, there will be no dividing or combining control until the flow reaches the minimum rating.
- Divisional and combining accuracy are equal.

FS * A - X A *

Nominal Capacity	Control	Flow Proportion	Seal
B 2,5-12 L/min.	X Non-adjustable	A 50/50 Flow Split	N Buna-N
C 6-30 L/min.			V Viton
D 12-60 L/min.			
E 23-120 L/min.			
F 45-240 L/min.			

Divisional Accuracy (Combining and Dividing) =
 ± 4.5 % at minimum input flow
 ± 2.5 % at maximum input flow

Visit www.sunhydraulics.com for detailed and complete technical information on our full line of products.

SYNCHRONIZING DIVIDER / COMBINER

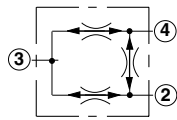
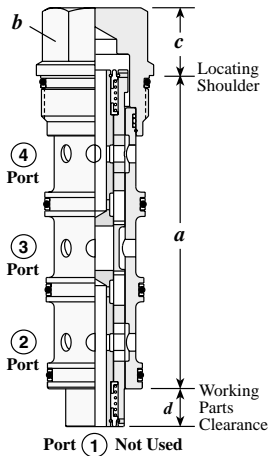

Capacity Min/Max	Typical Cartridge Model Code	Cavity	Cartridge Dimensions				Installation Torque (Nm)
			a	b	c	d	
2,5-12 L/min.	FSBS – XAN	T - 31A	84,8	22,2	19	17	40/50
6-30 L/min.	FSCS – XAN	T - 31A	84,8	22,2	19	17	40/50
12-60 L/min.	FSDS – XAN	T - 32A	92,2	28,6	18	20	60/70
23-120 L/min.	FSES – XAN	T - 33A	114,4	31,8	25	26	200/215
45-240 L/min.	FSFS – XAN	T - 34A	139,7	41,3	31	30	465/500

Performance Curves

Operating Characteristics

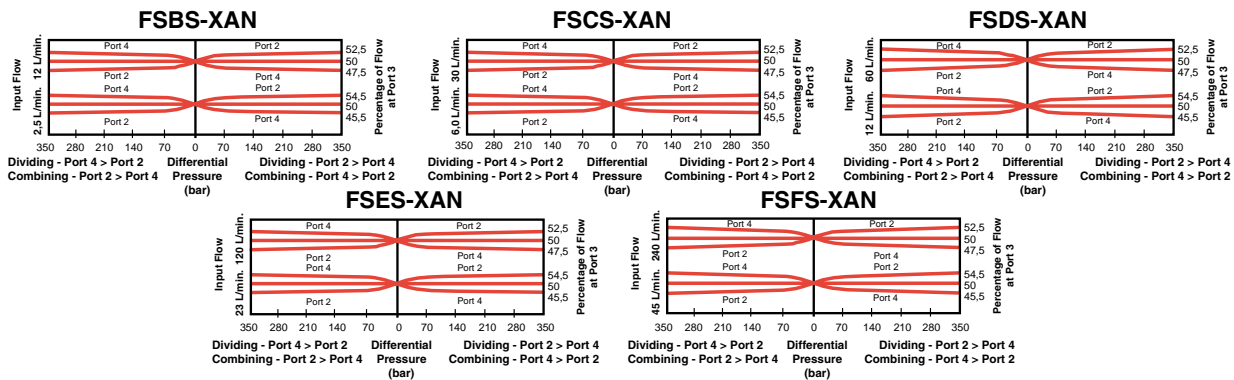

- Maximum operating pressure = 350 bar
- Divisional accuracy at rated maximum input flow = 50% ±2.5%
- Divisional accuracy at rated minimum input flow = 50% ±4.5%
- Pressure drop at maximum input flow = 24 bar
- Pressure drop at minimum input flow = 1,7 bar
- Below the minimum flow rating there is not enough flow for the valve to modulate. It is effectively a tee. If flow starts at zero and rises, there will be no dividing or combining control until the flow reaches the minimum rating.
- The synchronization feature provides bi-directional static error correction.
- Divisional and combining accuracy are equal.

FS * S - X A *

Nominal Capacity	Control	Flow Proportion	Seal
B 2,5-12 L/min.	X Non-adjustable	A 50/50 Flow Split	N Buna-N
C 6-30 L/min.			V Viton
D 12-60 L/min.			
E 23-120 L/min.			
F 45-240 L/min.			

Divisional Accuracy (Combining and Dividing) =
 ± 4.5 % at minimum input flow
 ± 2.5 % at maximum input flow
 Synchronizing Flow per Leg:
 FSBS: 0,6 - 1 L/min.
 FSCS: 0,75 - 2 L/min.
 FSDS: 1,2 - 2,5 L/min.
 FSES: 3 - 6 L/min.
 FSFS: 9 - 13 L/min.

Visit www.sunhydraulics.com for detailed and complete technical information on our full line of products.

HIGH CAPACITY DIVIDER / COMBINER, CLOSED CENTER

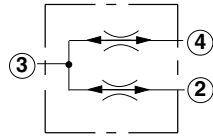
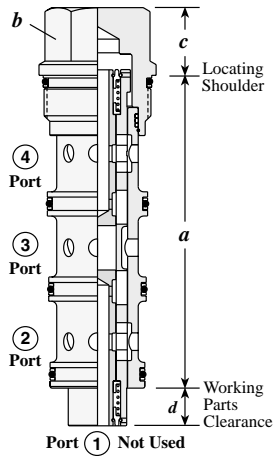

Note: Closed center valves have spring centered internal spools that provide blocked flow paths when centered. Centering occurs when the Port 3 flow is also blocked. This internal blocking isolates Port 2 and 4 from cross flow.

Capacity Min/Max	Typical Cartridge Model Code	Cavity	Cartridge Dimensions				Installation Torque (Nm)
			a	b	c	d	
8-40 L/min.	FSCH - XAN	T - 31A	84,8	22,2	19	17	40/50
15-80 L/min.	FSDH - XAN	T - 32A	92,2	28,6	18	20	60/70
32-160 L/min.	FSEH - XAN	T - 33A	114,4	31,8	25	26	200/215
60-320 L/min.	FSFH - XAN	T - 34A	139,7	41,3	31	30	465/500

Performance Curves

Constant Command - Varying Flow

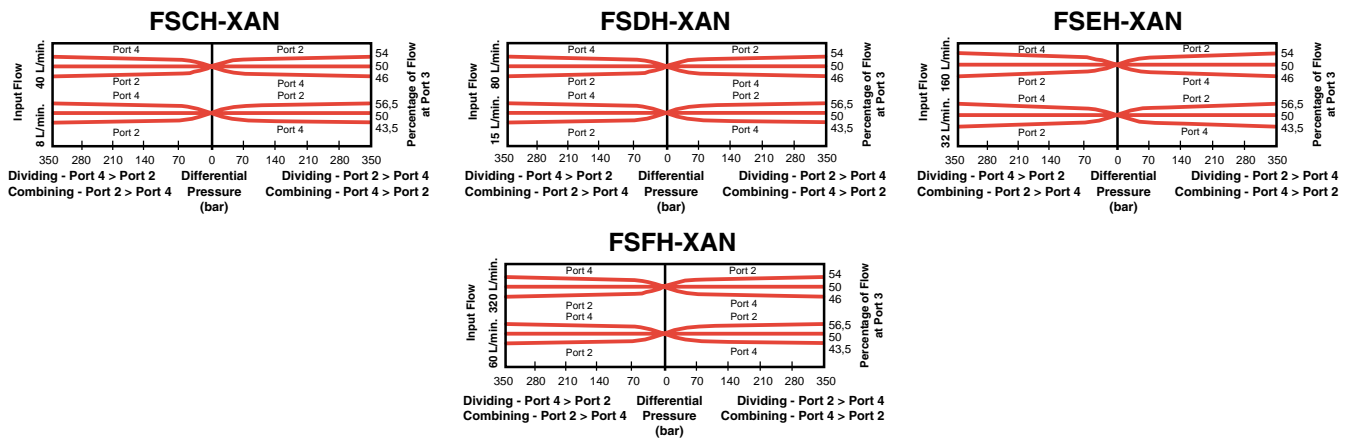

- Maximum operating pressure = 350 bar
- Divisional accuracy at rated maximum input flow = 50% ±4%
- Divisional accuracy at rated minimum input flow = 50% ±6.5%
- Pressure drop at maximum input flow = 24 bar
- Pressure drop at minimum input flow = 1,7 bar
- Below the minimum flow rating there is not enough flow for the valve to modulate. It is effectively a tee. If flow starts at zero and rises, there will be no dividing or combining control until the flow reaches the minimum rating.
- Divisional and combining accuracy are equal.

FS * H - X A *



Nominal Capacity	Control	Flow Proportion	Seal
C 8-40 L/min.	X Non-adjustable	A 50/50 Flow Split	N Buna-N
D 15-80 L/min.			V Viton
E 32-160 L/min.			
F 60-320 L/min.			

Divisional Accuracy (Combining and Dividing) =
 ± 6.5 % at minimum input flow
 ± 4.0 % at maximum input flow

Visit www.sunhydraulics.com for detailed and complete technical information on our full line of products.

NOTES

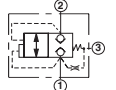
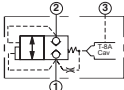
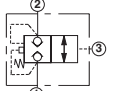
Logic Elements

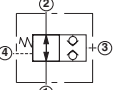
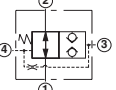
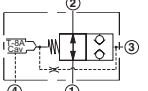
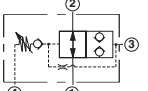
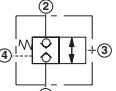
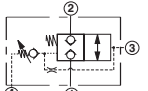
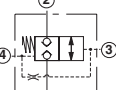
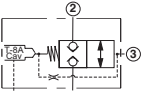
<i>Cartridge Type</i>	<i>Page</i>
	Unbalanced Poppet, Pilot-to-Close Switching Element 88
	Unbalanced Poppet, Pilot-to-Close Switching Element with Integral Pilot Control Cavity 89
	Unbalanced Poppet, Pilot-to-Open Switching Element 90
	Normally Open Modulating Element 91
	Normally Closed Modulating Element 92
	Normally Open, Direct Operated 93
	Normally Open, Vent-to-Operate 94
	Normally Open, Vent-to-Operate with Integral Pilot Control Cavity 95
	Normally Open, Pressure Adjustable 96
	Normally Closed, Direct Operated 97
	Normally Closed, Pressure Adjustable 98
	Normally Closed, Vent-to-Operate 99
	Normally Closed, Vent-to-Operate with Integral Pilot Control Cavity 100

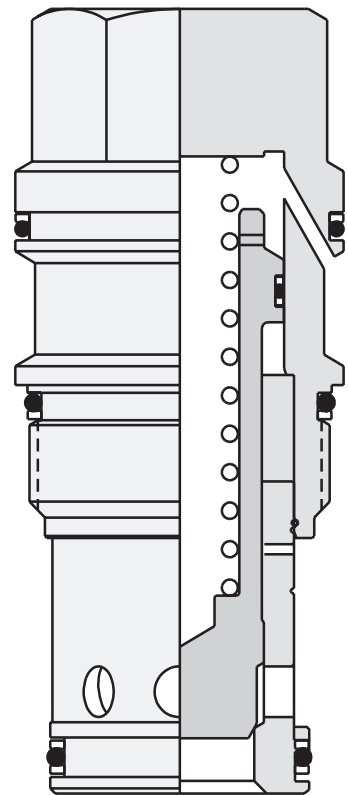

UNBALANCED POPPET, PILOT-TO-CLOSE SWITCHING ELEMENT

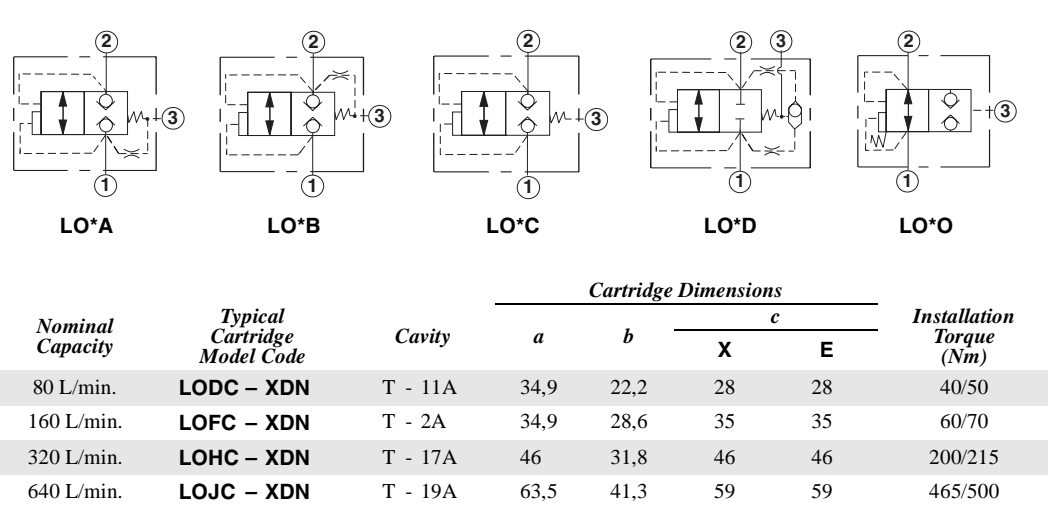
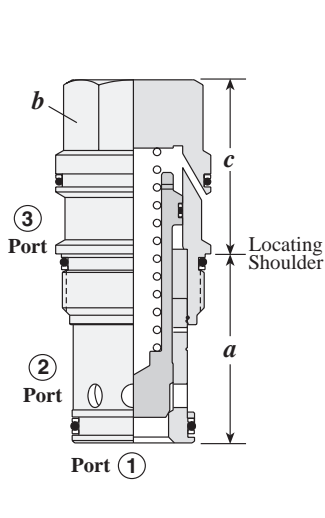

Performance Curves

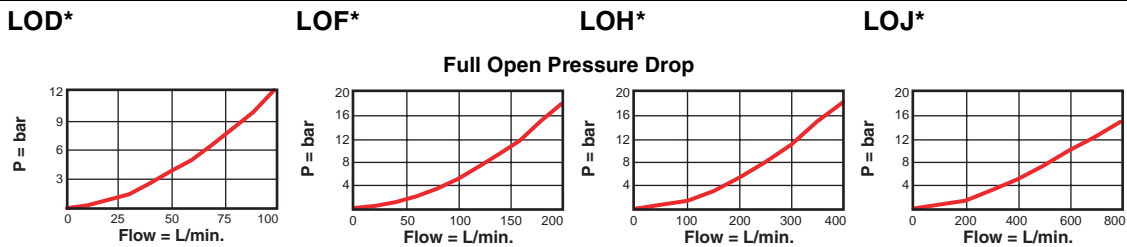

- Maximum operating pressure = 350 bar
- Area ratio: A3 to A1 = 1.8:1
- Area ratio: A3 to A2 = 2.25:1
- Control orifice diameter = LODA, LODB, LODD, LOFA, LOFB, LOFD: 0,53 mm, LOHA, LOHB, LOHD: 0,8 mm, LOJA, LOJB, LOJD: 0,9 mm.
- Pilot volume for complete shift = LOD*: 0,6 c.c., LOF*: 1,1 c.c., LOH*: 4,1 c.c., LOJ*: 6,9 c.c.
- These valves are pressure responsive at all three ports, therefore it is essential to consider all aspects of system operation through a complete cycle. Pressure changes at any one port may cause a valve to switch from a closed to an open position, or vice versa. All possible pressure changes in the complete circuit must be considered to assure a safe, functional system design.

Nominal Capacity	Version	Control**	Cracking Pressure A, B, C, D Versions	Seal
D 80 L/min.	A Spring biased closed Port 1 pilot source	X Non-adjustable	D 3,5 bar at Port 1 (2 bar to close at Port 3 for O Version)	N Buna-N
F 160 L/min.	B Spring biased closed Port 2 pilot source	<i>Available in B and C Versions Only</i>		V Viton
H 320 L/min.	C Spring biased closed Port 3 pilot source	E SAE-4 Port in Hex Body, Port 3 blocked		
J 640 L/min.	D Spring biased closed higher of Ports 1 or 2 pilot source	<i>Available in D and F Capacities Only</i>		
	O Spring biased open Port 3 pilot source	L Stroke Adjustment		

** See page 162 for information on Control Options

Visit www.sunhydraulics.com for detailed and complete technical information on our full line of products.

UNBALANCED POPPET, PILOT-TO-CLOSE SWITCHING ELEMENT WITH INTEGRAL PILOT CONTROL CAVITY

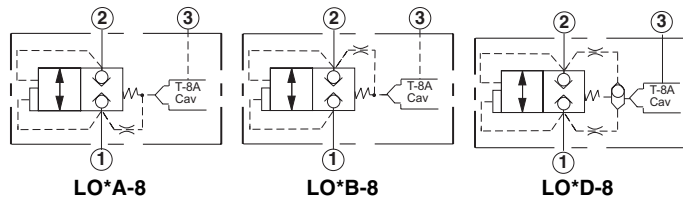
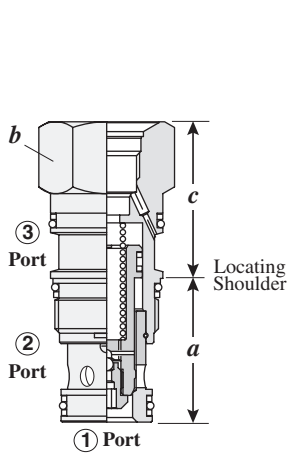

The -8 control option allows a pilot control valve to be incorporated directly into the end of the cartridge via the T-8A cavity. These pilot control cartridges are sold separately and include solenoid and air pilot operation. See Pilot Control Cartridges on page 121.

Nominal Capacity	Typical Cartridge Model Code	Cavity	Cartridge Dimensions			Installation Torque (Nm)
			a	b	c	
80 L/min.	LODA – 8DN	T - 11A	34,9	22,2	28	40/50
160 L/min.	LOFA – 8DN	T - 2A	34,9	28,6	35	60/70
320 L/min.	LOHA – 8DN	T - 17A	46	31,8	46	200/215
640 L/min.	LOJA – 8DN	T - 19A	63,5	41,3	59	465/500

Performance Curves

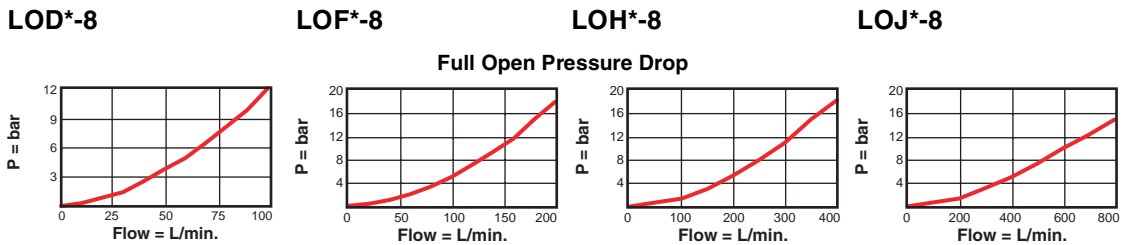

- Maximum operating pressure = 350 bar
- Area ratio: A3 to A1 = 1.8:1
- Area ratio: A3 to A2 = 2.25:1
- Control orifice diameter = LOD*-8, LOF*-8, LOF*-8: 0,53 mm, LOH*-8, LOH*-8: 0,8 mm, LOJ*-8, LOJ*-8: 0,9 mm.
- These valves are pressure responsive at all three ports, therefore it is essential to consider all aspects of system operation through a complete cycle. Pressure changes at any one port may cause a valve to switch from a closed to an open position, or vice versa. All possible pressure changes in the complete circuit must be considered to assure a safe, functional system design.
- With the -8 control option, the main stage valve should first be installed to the correct torque value. The T-8A pilot control valve should then be installed into the main stage valve to its required torque value.

Nominal Capacity	Version	Control**	Cracking Pressure A, B, D Versions	Seal
D 80 L/min.	A Spring biased closed Port 1 pilot source	8 T-8A Cavity in hex body for pilot operation (Pilot valve to be ordered separately)	D 3,5 bar at Port 1	N Buna-N
F 160 L/min.	B Spring biased closed Port 2 pilot source			V Viton
H 320 L/min.				
J 640 L/min.	D Spring biased closed higher of Ports 1 or 2 pilot source			

** See page 162 for information on Control Options

Visit www.sunhydraulics.com for detailed and complete technical information on our full line of products.

UNBALANCED POPPET, PILOT-TO-OPEN SWITCHING ELEMENT

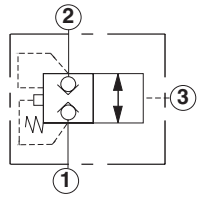
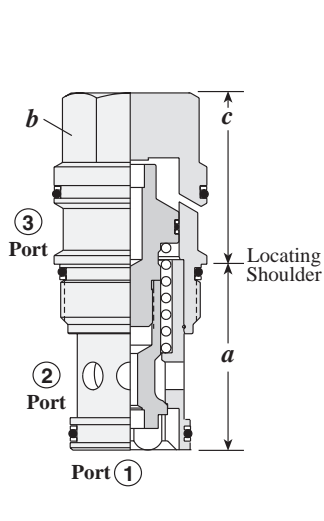

Nominal Capacity	Typical Cartridge Model Code	Cavity	Cartridge Dimensions			Installation Torque (Nm)
			a	b	c	
60 L/min.	LKDC – XDN	T - 11A	34,9	22,2	28	40/50
120 L/min.	LKFC – XDN	T - 2A	34,9	28,6	35	60/70
240 L/min.	LKHC – XDN	T - 17A	46	31,8	46	200/215
480 L/min.	LKJC – XDN	T - 19A	63,5	41,3	59	465/500

Performance Curves

LKDC

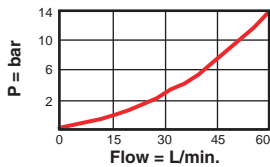

LKFC

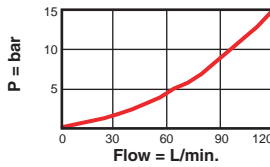

LKHC

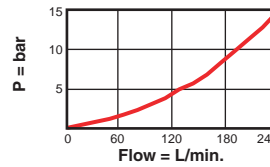

LKJC

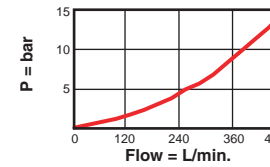

Full Open Pressure Drop

- Maximum operating pressure = 350 bar
- Area ratio: A3 to A1 = 1.8:1
- Area ratio: A3 to A2 = 2.25:1
- Control orifice diameter = LKDC: 0,8 mm, LKFC: 0,9 mm, LKHC: 1,6 mm, LKJC: 2,4 mm
- Pilot volume for complete shift = LKDC: 0,33 c.c., LKFC: 1,0 c.c., LKHC: 2,5 c.c., LKJC: 4,9 c.c.
- These valves are pressure responsive at all three ports, therefore it is essential to consider all aspects of system operation through a complete cycle. Pressure changes at any one port may cause a valve to switch from a closed to an open position, or vice versa. All possible pressure changes in the complete circuit must be considered to assure a safe, functional system design.

	LK ★ ★		-	★ ★ ★		
<i>Nominal Capacity</i>	<i>Version</i>		<i>Control**</i>	<i>Cracking Pressure</i>		<i>Seal</i>
D 60 L/min.	C Port 3 pilot source		X Non-adjustable	D 3,5 bar at Port 3		N Buna-N
F 120 L/min.			<i>Available in D and F Capacities Only</i>			V Viton
H 240 L/min.			L Manual Release			
J 480 L/min.						

** See page 162 for information on Control Options

Visit www.sunhydraulics.com for detailed and complete technical information on our full line of products.

NORMALLY OPEN MODULATING ELEMENT

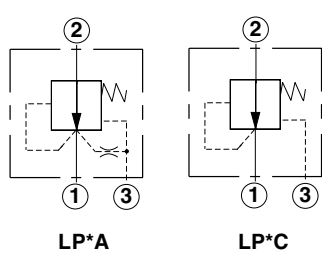
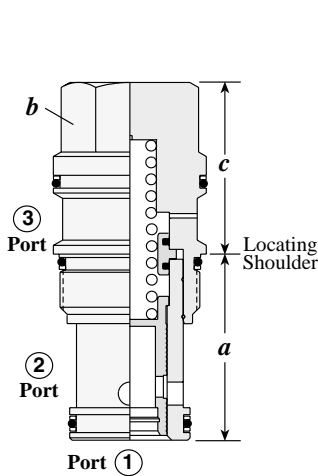

Nominal Capacity	Typical Cartridge Model Code	Cavity	Cartridge Dimensions				Installation Torque (Nm)
			a	b	c		
30 L/min.	LPBC – XHN	T - 163A	31	19,1	X	L	35/40
60 L/min.	LPDC – XHN	T - 11A	34,9	22,2	31	64	40/50
120 L/min.	LPFC – XHN	T - 2A	34,9	28,6	35	72	60/70
240 L/min.	LPHC – XHN	T - 17A	46	31,8	46	84	200/215
480 L/min.	LPJC – XHN	T - 19A	63,5	41,3	59	100	465/500

Performance Curves

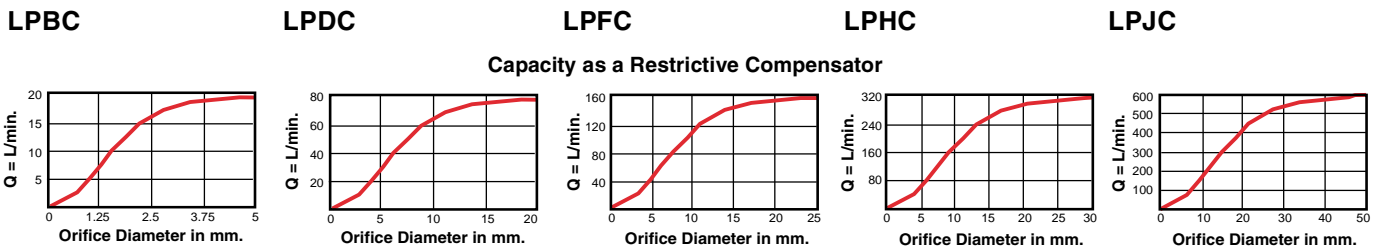

- Maximum operating pressure = 350 bar
- Maximum leakage at 150 SUS, port 3 = 16,4 cc/min.
- Control orifice diameter = LPB*, LPD*, LPF*: 0,4 mm, LPH*, LPJ*: 0,53 mm.

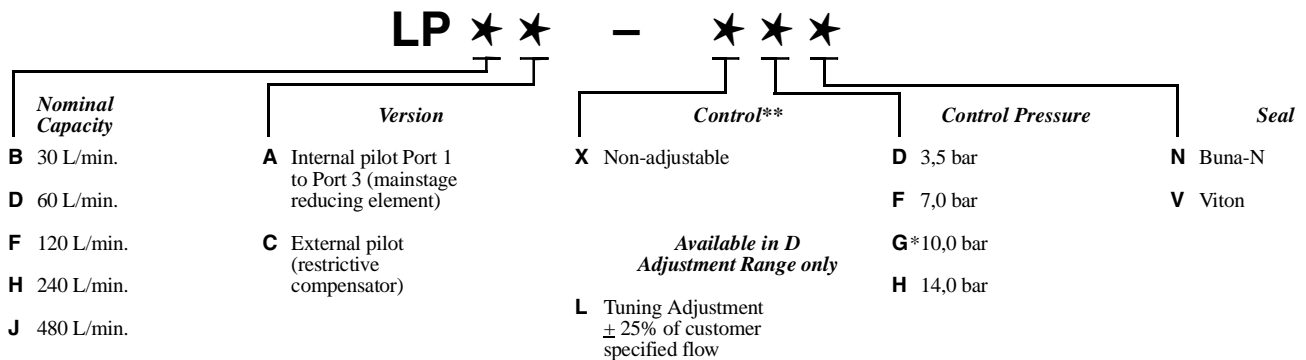

** See page 162 for information on Control Options

* G Adjustment Range not available in LPBA, LPBC.

Visit www.sunhydraulics.com for detailed and complete technical information on our full line of products.

NORMALLY CLOSED MODULATING ELEMENT

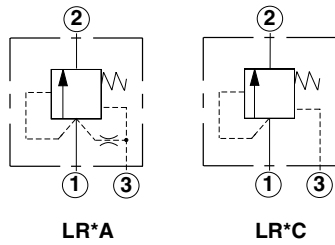
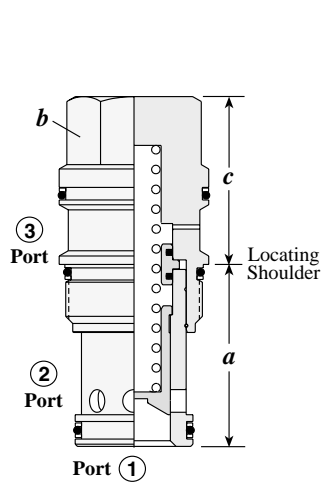

Nominal Capacity	Typical Cartridge Model Code	Cavity	Cartridge Dimensions				Installation Torque (Nm)
			a	b	c		
					X	L	
30 L/min.	LRBC – XHN	T - 163A	31	19,1	32	65	35/40
60 L/min.	LRDC – XHN	T - 11A	34,9	22,2	31	64	40/50
120 L/min.	LRFC – XHN	T - 2A	34,9	28,6	35	72	60/70
240 L/min.	LRHC – XHN	T - 17A	46	31,8	46	84	200/215
480 L/min.	LRJC – XHN	T - 19A	63,5	41,3	59	100	465/500

- Maximum operating pressure = 350 bar
- Control orifice diameter = LRB*, LRD*, LRF*: 0,4 mm, LRH*, LRJ*: 0,53 mm.

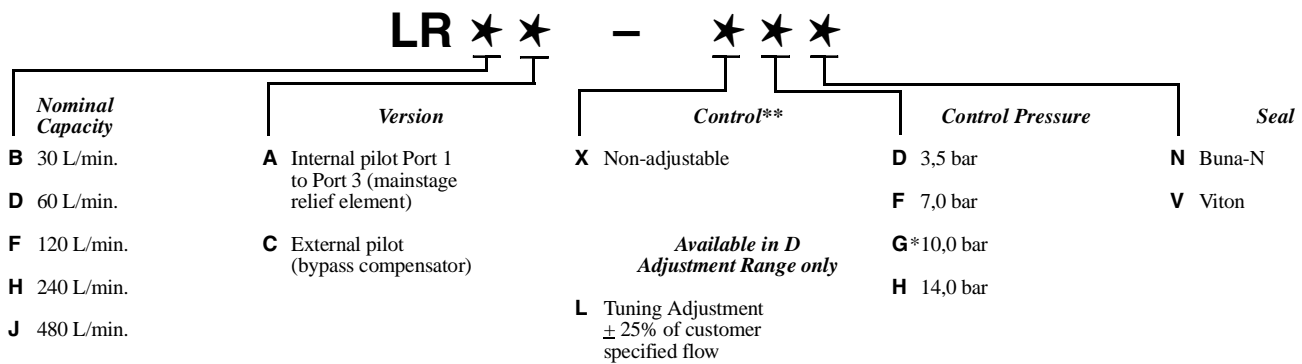

** See page 162 for information on Control Options

* G Adjustment Range not available in LRBA, LRBC.

Visit www.sunhydraulics.com for detailed and complete technical information on our full line of products.

NORMALLY OPEN, DIRECT OPERATED

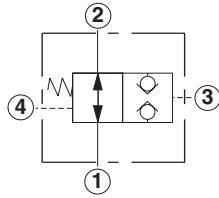
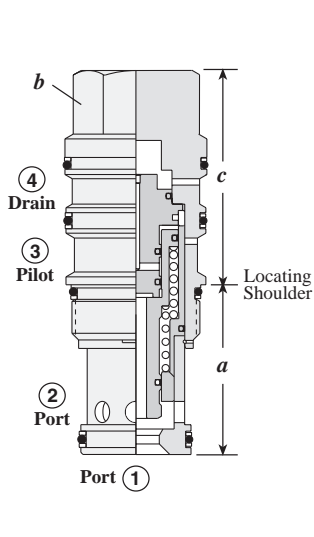

Nominal Capacity	Typical Cartridge Model Code	Cavity	Cartridge Dimensions			Installation Torque (Nm)
			a	b	c	
60 L/min.	DODS – XHN	T - 21A	34,9	22,2	46	40/50
120 L/min.	DOFS – XHN	T - 22A	34,9	28,6	51	60/70
240 L/min.	DOHS – XHN	T - 23A	46	31,8	63	200/215
480 L/min.	DOJS – XHN	T - 24A	63,5	41,3	81	465/500

Performance Curves

DODS

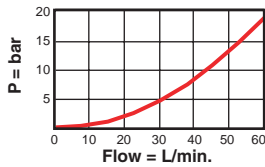

DOFS

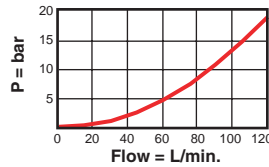

DOHS

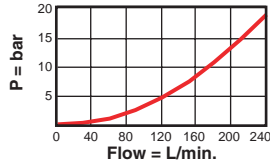

DOJS

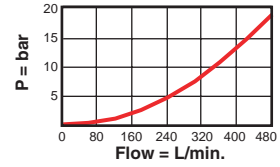

Fully Open Pressure Differential vs. Flow

- Maximum operating pressure = 350 bar (Port 1 and Port 2)
- Minimum pilot pressure to shift valve = DODS: 30 bar, DOFS, DOHS, DOJS: 20 bar,
- Maximum valve leakage, Port 1 to Port 2 or Port 2 to Port 1 = 0,4 cc/min.
- Pilot volume for complete shift = DODS: 0,16 c.c., DOFS: 0,33 c.c., DOHS: 0,82 c.c., DOJS: 2,8 c.c.
- Valve will open when the pilot pressure falls below 10 bar.
- Any back pressure at the drain port is directly additive to the required pilot pressure for reliable operation.

DO * S - * H *

Nominal Capacity	Control**	Control Pressure	Seal
D 60 L/min.	X Non-adjustable	H 14,0 bar	N Buna-N
F 120 L/min.			V Viton
H 240 L/min.			
J 480 L/min.			

** See page 162 for information on Control Options

Visit www.sunhydraulics.com for detailed and complete technical information on our full line of products.

NORMALLY OPEN, VENT-TO-OPERATE

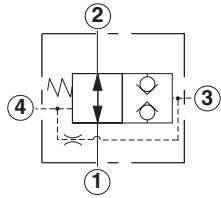
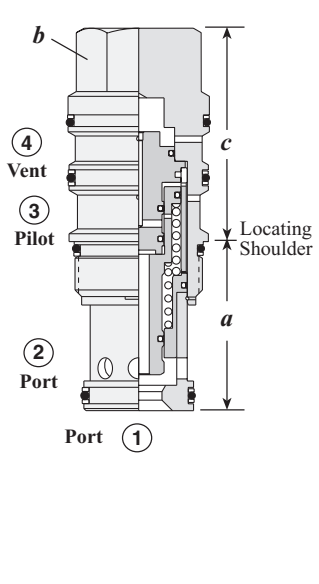

Nominal Capacity	Typical Cartridge Model Code	Cavity	Cartridge Dimensions			Installation Torque (Nm)
			a	b	c	
60 L/min.	DODR – XHN	T - 21A	34,9	22,2	46	40/50
120 L/min.	DOFR – XHN	T - 22A	34,9	28,6	51	60/70
240 L/min.	DOHR – XHN	T - 23A	46	31,8	63	200/215
480 L/min.	DOJR – XHN	T - 24A	63,5	41,3	81	465/500

Performance Curves

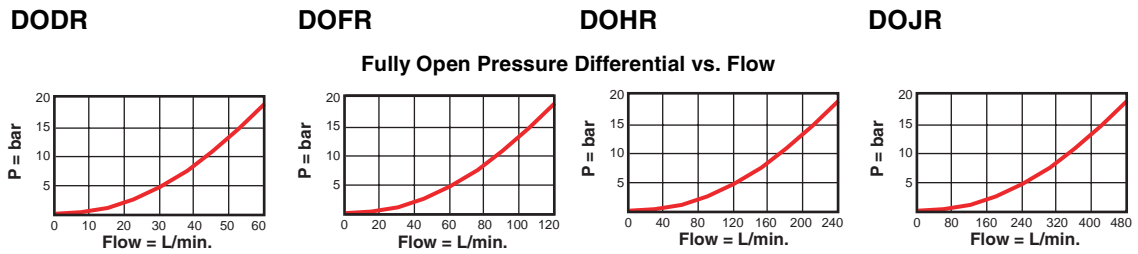

- Maximum operating pressure = 350 bar
- Minimum pilot pressure to shift valve with Port 4 vented to tank = DODR: 30 bar, DOFR, DOHR, DOJR: 20 bar
- Maximum valve leakage, Port 1 to Port 2 or Port 2 to Port 1 = 0,4 cc/min.
- Control pilot flow = DODR, DOFR: 0,4 L/min., DOHR, DOJR: 0,6 L/min.
- Valve will open when the pilot pressure falls below 10 bar or with Port 4 blocked.
- Port 4 may be externally connected to a pilot switching valve. The pilot valve should have a leakage rate of less than 10 drops/min. and be able to satisfy the pilot flow requirements. Sun model DAAA-*** solenoid pilot valve is ideal for this application.

DO * R - * * *

Nominal Capacity	Control**	Control Pressure	Seal
D 60 L/min.	X Non-adjustable	H 14,0 bar	N Buna-N
F 120 L/min.			V Viton
H 240 L/min.			
J 480 L/min.			

** See page 162 for information on Control Options

Visit www.sunhydraulics.com for detailed and complete technical information on our full line of products.

NORMALLY OPEN, VENT-TO-OPERATE WITH INTEGRAL PILOT CONTROL CAVITY

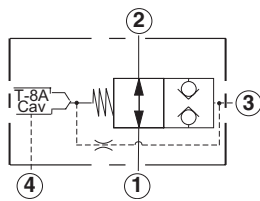
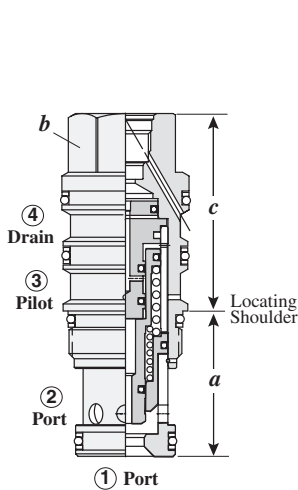

The -8 control option allows a pilot control valve to be incorporated directly into the end of the cartridge via the T-8A cavity. These pilot control cartridges are sold separately and include solenoid, air pilot, and hydraulic pilot operation. See Pilot Control Cartridges on page 121.

Nominal Capacity	Typical Cartridge Model Code	Cavity	Cartridge Dimensions			Installation Torque (Nm)
			a	b	c	
60 L/min.	DODR - 8HN	T - 21A	34,9	22,2	46	40/50
120 L/min.	DOFR - 8HN	T - 22A	34,9	28,6	51	60/70
240 L/min.	DOHR - 8HN	T - 23A	46	31,8	63	200/215
480 L/min.	DOJR - 8HN	T - 24A	63,5	41,3	81	465/500

Performance Curves

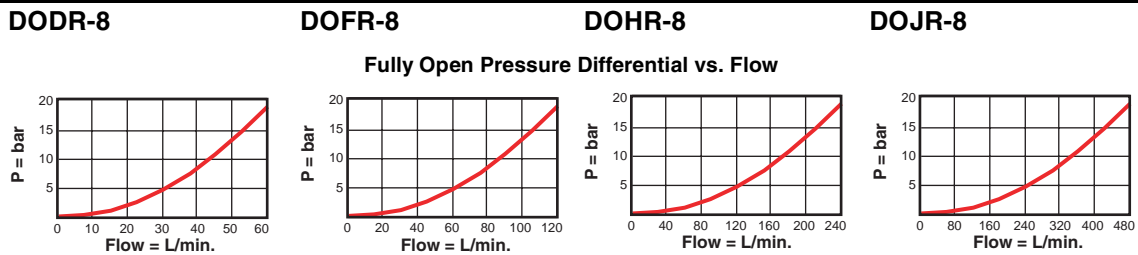

- Maximum operating pressure = 350 bar
- Minimum pilot pressure to shift valve = DODR: 30 bar, DOFR, DOHR, DOJR: 20 bar,
- Maximum valve leakage, Port 1 to Port 2 or Port 2 to Port 1 = 0,4 cc/min.
- Control pilot flow = DODR, DOFR: 0,4 L/min., DOHR, DOJR: 0,6 L/min.
- Valve will open when the pilot pressure falls below 10 bar.
- Any back pressure at the drain port is directly additive to the required pilot pressure.
- With the -8 control option, the main stage valve should first be installed to the correct torque value. The T-8A pilot control valve should then be installed into the main stage valve to its required torque value.

DO ★ R - 8 ★ ★

Nominal Capacity	Control**	Control Pressure	Seal
D 60 L/min.	8 with T-8A cavity in hex body for pilot operation (see pilot control section for alternate options)	H 14,0 bar	N Buna-N
F 120 L/min.			V Viton
H 240 L/min.			
J 480 L/min.			

** See page 162 for information on Control Options

Visit www.sunhydraulics.com for detailed and complete technical information on our full line of products.

NORMALLY OPEN, PRESSURE ADJUSTABLE

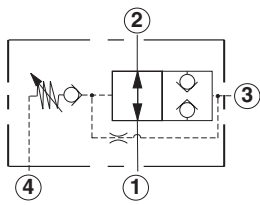
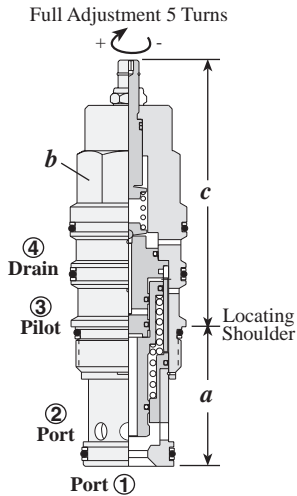

Nominal Capacity	Typical Cartridge Model Code	Cavity	a	b	Cartridge Dimensions			Installation Torque (Nm)
					L	C	K	
60 L/min.	DODP – LAN	T - 21A	34,9	22,2	79	80,0	85,0	40/50
120 L/min.	DOFP – LAN	T - 22A	34,9	28,6	88	89,0	94,0	60/70
240 L/min.	DOHP – LAN	T - 23A	46	31,8	100	101,0	106,0	200/215
480 L/min.	DOJP – LAN	T - 24A	63,5	41,3	122	125,0	128,0	465/500

Performance Curves

DODP

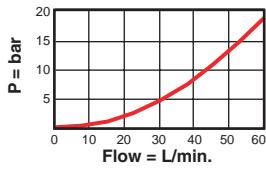

DOFP

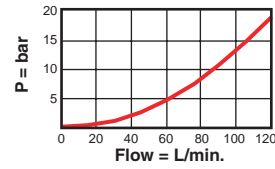

DOHP

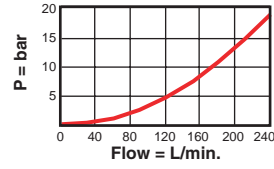

DOJP

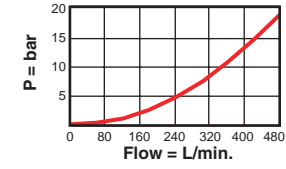

Fully Open Pressure Differential vs. Flow

- Maximum operating pressure = 350 bar
- Minimum pilot pressure to shift valve = DODP: 30 bar, DOFP, DOHP, DOJP: 20 bar,
- Maximum valve leakage, Port 1 to Port 2 or Port 2 to Port 1 = 0,4 cc/min.
- Control pilot flow at shift = DODP, DOFP: 0,4 L/min., DOHP, DOJP: 0,6 L/min.
- Valve will open when the pilot pressure drops 85% below setting.
- Any back pressure at the drain port is directly additive to the required pilot pressure.

DO * P - * * *

Nominal Capacity	Control**	Nominal Adjustable Shift Pressure Range	Seal
D 60 L/min.	L Standard Screw	A 21 - 210 bar	N Buna-N
F 120 L/min.	C Tamper Resistant	B 21 - 105 bar	V Viton
H 240 L/min.	K Handknob	W 21 - 315 bar	
J 480 L/min.			

** See page 162 for information on Control Options

Customer may specify pressure setting.

Visit www.sunhydraulics.com for detailed and complete technical information on our full line of products.

NORMALLY CLOSED, DIRECT OPERATED

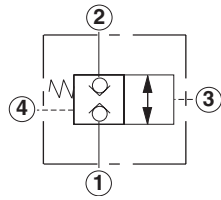
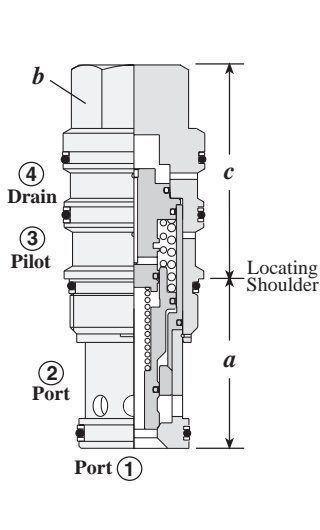

Nominal Capacity	Typical Cartridge Model Code	Cavity	Cartridge Dimensions			Installation Torque (Nm)
			a	b	c	
60 L/min.	DKDS – XHN	T - 21A	34,9	22,2	46	40/50
120 L/min.	DKFS – XHN	T - 22A	34,9	28,6	51	60/70
240 L/min.	DKHS – XHN	T - 23A	46	31,8	63	200/215
480 L/min.	DKJS – XHN	T - 24A	63,5	41,3	81	465/500

Performance Curves

DKDS

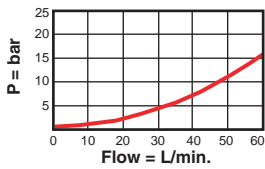

DKFS

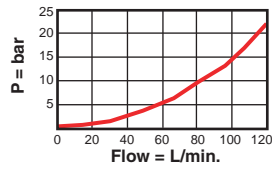

DKHS

Pilot Open Pressure Drop

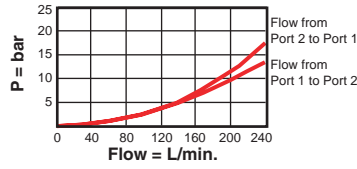

DKJS

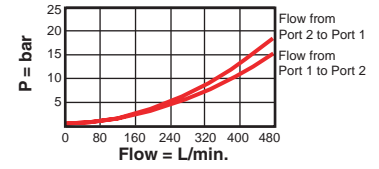

- Maximum operating pressure = 350 bar
- Minimum pilot pressure to shift valve = DKDS: 30 bar, DKFS, DKHS, DKJS: 20 bar,
- Maximum valve leakage, Port 1 to Port 2 or Port 2 to Port 1 = 0,4 cc/min.
- Pilot volume for complete shift = DKDS: 0,16 c.c., DKFS: 0,33 c.c., DKHS: 0,82 c.c., DKJS: 2,8 c.c.
- Valve will reset when the pilot pressure drops 85% below setting.
- Any back pressure at the drain port is directly additive to the required pilot pressure.

DK ★ S – ★ ★ ★

Nominal Capacity	Control**	Adjustment Range	Seal
D 60 L/min.	X Non-adjustable	H 14,0 bar	N Buna-N
F 120 L/min.			V Viton
H 240 L/min.			
J 480 L/min.			

** See page 162 for information on Control Options

Visit www.sunhydraulics.com for detailed and complete technical information on our full line of products.

NORMALLY CLOSED, PRESSURE ADJUSTABLE

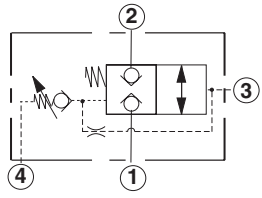
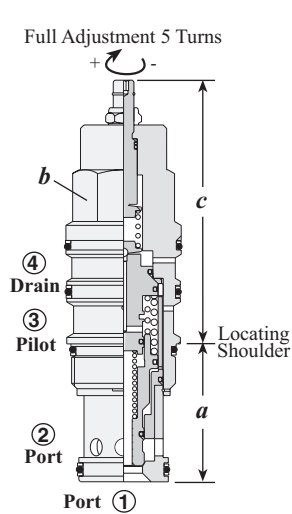

Nominal Capacity	Typical Cartridge Model Code	Cavity	a	b	Cartridge Dimensions			Installation Torque (Nm)
					L	C	K	
60 L/min.	DKDP – LAN	T - 21A	34,9	22,2	79	80,0	85,0	40/50
120 L/min.	DKFP – LAN	T - 22A	34,9	28,6	88	89,0	94,0	60/70
240 L/min.	DKHP – LAN	T - 23A	46	31,8	100	101,0	106,0	200/215
480 L/min.	DKJP – LAN	T - 24A	63,5	41,3	122	125,0	128,0	465/500

Performance Curves

DKDP

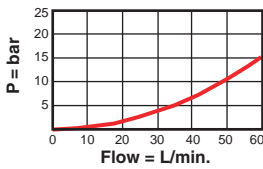

DKFP

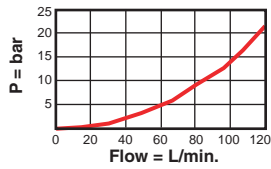

DKHP

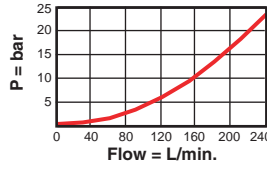

DKJP

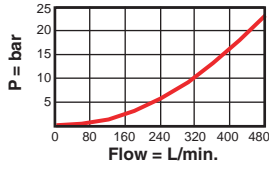

Piloted Open Pressure Drop

- Maximum operating pressure = 350 bar
- Minimum pilot pressure to shift valve = DKDP: 30 bar, DKFP, DKHP, DKJP: 20 bar,
- Maximum valve leakage, Port 1 to Port 2 or Port 2 to Port 1 = 0,4 cc/min.
- Control pilot flow at shift = DKDP, DKFP: 0,4 L/min., DKHP, DKJP: 0,6 L/min.
- Any back pressure at the drain port is directly additive to the required pilot pressure.
- Valve will reset when the pilot pressure falls to 85% of the cracking value.

DK ★ P – ★ ★ ★

Nominal Capacity	Control**	Nominal Adjustable Shift Pressure Range	Seal
D 60 L/min.	L Standard Screw	A 21 - 210 bar	N Buna-N
F 120 L/min.	C Tamper Resistant	B 21 - 105 bar	V Viton
H 240 L/min.	K Handknob	W 21 - 315 bar	
J 480 L/min.			

** See page 162 for information on Control Options

Adjustment Range Options:
A, B, and W are standard set at 70 bar.
Customer may specify pressure setting.

Visit www.sunhydraulics.com for detailed and complete technical information on our full line of products.

NORMALLY CLOSED, VENT-TO-OPERATE

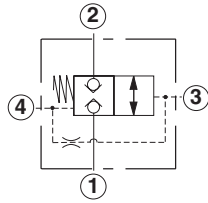
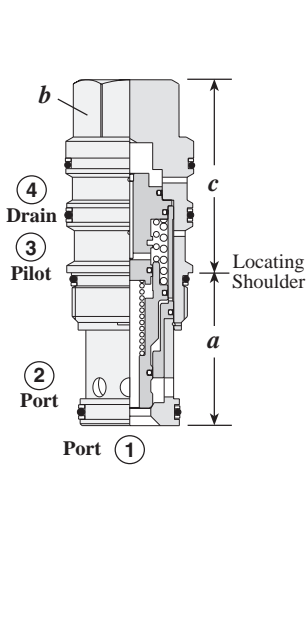

Nominal Capacity	Typical Cartridge Model Code	Cavity	Cartridge Dimensions			Installation Torque (Nm)
			a	b	c	
60 L/min.	DKDR – XHN	T - 21A	34,9	22,2	46	40/50
120 L/min.	DKFR – XHN	T - 22A	34,9	28,6	51	60/70
240 L/min.	DKHR – XHN	T - 23A	46	31,8	63	200/215
480 L/min.	DKJR – XHN	T - 24A	63,5	41,3	81	465/500

Performance Curves

DKDR

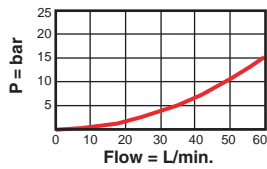

DKFR

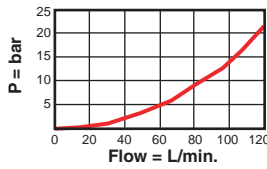

DKHR

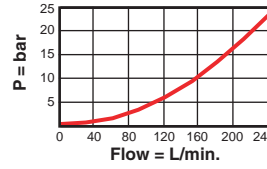

DKJR

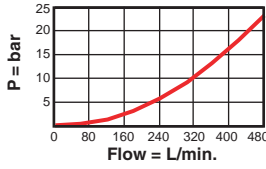

Piloted Open Pressure Drop

- Maximum operating pressure = 350 bar
- Minimum pilot pressure to shift valve with Port 4 vented to tank = DKDR: 30 bar, DKFR, DKHR, DKJR: 20 bar.
- Maximum valve leakage, Port 1 to Port 2 or Port 2 to Port 1 = 0,4 cc/min.
- Control pilot flow = DKDR, DKFR: 0,4 L/min., DKHR, DKJR: 0,6 L/min.
- Valve will reseat when the pilot pressure falls below 10 bar.
- Port 4 may be externally connected to a pilot switching valve. The pilot valve should have a leakage rate of less than 10 drops/min. and be able to satisfy the pilot flow requirements. Sun model DAAA-*** solenoid pilot valve is ideal for this application.

DK ★ R – ★ ★ ★

Nominal Capacity	Control**	Nominal Shift Pressure	Seal
D 60 L/min.	X Non-adjustable	H 14,0 bar	N Buna-N
F 120 L/min.			V Viton
H 240 L/min.			
J 480 L/min.			

** See page 162 for information on Control Options

Visit www.sunhydraulics.com for detailed and complete technical information on our full line of products.

NORMALLY CLOSED, VENT-TO-OPERATE WITH INTEGRAL PILOT CONTROL CAVITY

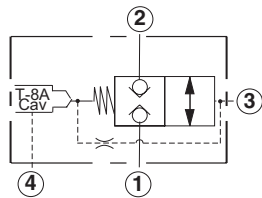
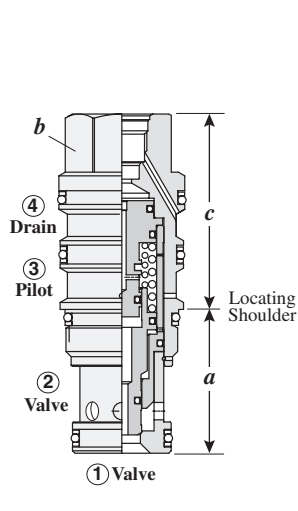

The -8 control option allows a pilot control valve to be incorporated directly into the end of the cartridge via the T-8A cavity. These pilot control cartridges are sold separately and include electro-proportional, solenoid, air pilot, and hydraulic pilot operation. See Pilot Control Cartridges on page 121.

Nominal Capacity	Typical Cartridge Model Code	Cavity	Cartridge Dimensions			Installation Torque (Nm)
			a	b	c	
60 L/min.	DKDR – 8H*	T - 21A	34,9	22,2	46	40/50
120 L/min.	DKFR – 8H*	T - 22A	34,9	28,6	51	60/70
240 L/min.	DKHR – 8H*	T - 23A	46	31,8	63	200/215
480 L/min.	DKJR – 8H*	T - 24A	63,5	41,3	81	465/500

Performance Curves

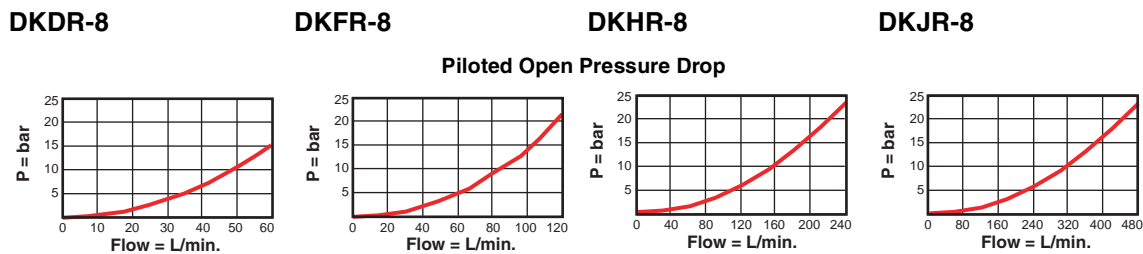

- Maximum operating pressure = 350 bar
- Minimum pilot pressure to shift valve with Port 4 vented to tank = DKDR: 30 bar, DKFR, DKHR, DKJR: 20 bar
- Maximum valve leakage, Port 1 to Port 2 or Port 2 to Port 1 = 0,4 cc/min.
- Control pilot flow = DKDR, DKFR: 0,4 L/min, DKHR, DKJR: 0,6 L/min.
- Valve will open when the pilot pressure falls below 10 bar.
- Any back pressure at the drain port is directly additive to the required pilot pressure for reliable operation.
- With the -8 control option, the main stage valve should first be installed to the correct torque value. The T-8A pilot control valve should then be installed into the main stage valve to its required torque value.

DK * R - 8 * *

Nominal Capacity	Control**	Nominal Shift Pressure	Seal
D 60 L/min.	8 with T-8A cavity in hex body for pilot operation (see pilot control section for alternate options)	H 14,0 bar	N Buna-N
F 120 L/min.			V Viton
H 240 L/min.			
J 480 L/min.			

** See page 162 for information on Control Options

Visit www.sunhydraulics.com for detailed and complete technical information on our full line of products.

Directional Cartridge Valves

	<i>Cartridge Type</i>	<i>Page</i>
	2-position, 2-way and 3-way, with Internal Drain	102
	2-position, 2-way and 3-way, with External Drain	103
	2-position, 2-way and 3-way Direct Acting, with Internal Drain	104
	2-position, 2-way and 3-way, Direct Acting	105
	3-port, 2-way and 3-way with Integral Pilot Control Cavity	106
	4-port, 2-way and 3-way with Integral Pilot Control Cavity	107
	2-position, 2-way Poppet, Control 1 to 2 with Integral Pilot Control Cavity	108
	2-position, 2-way Poppet, Control 2 to 1 with Integral Pilot Control Cavity	109
	3-position, 4-way Spring Centered	110
	2-position, 4-way Detented	111

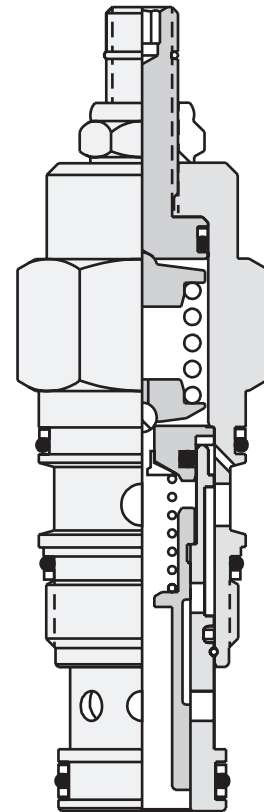

2 POSITION, 2-WAY AND 3-WAY, WITH INTERNAL DRAIN

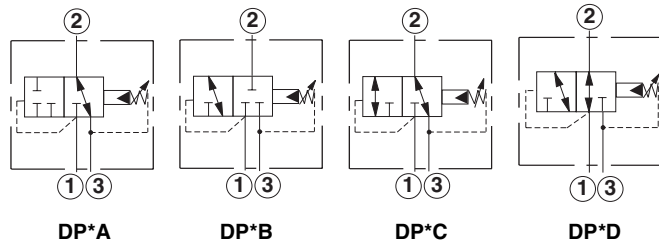
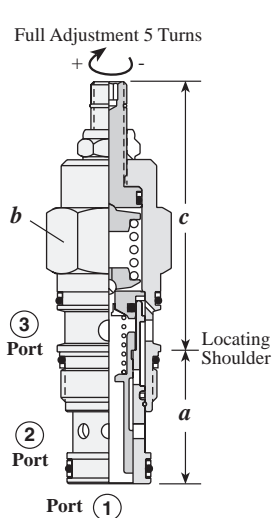

Capacity	Typical Cartridge Model Code	Cavity	Cartridge Dimensions					Installation Torque (Nm)
			a	b	L	C	K	
30 L/min.	DPBA – LAN	T - 11A	34,9	22,2	64	66	70	40/50
60 L/min.	DPCA – LAN	T - 2A	34,9	28,6	72	74	78	60/70

Performance Curves

DPB*

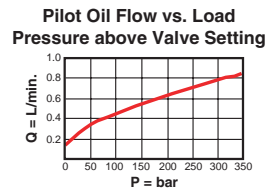
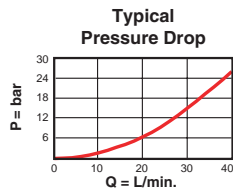

DPC*

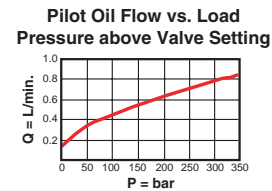
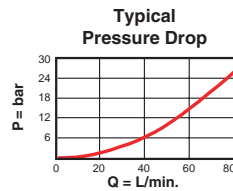

- Maximum operating pressure = 350 bar
- Maximum valve leakage = 16,4 cc/min. at 70 bar
- Control pilot flow at opening = DPBA, DPBB, DPBC, DPBD = 0,11 - 0,16 L/min., DPCA, DPCB, DPCC, DPCD = 0,16 - 0,25 L/min.
- Maximum pressure at port 3 should be limited to 210 bar.
- Pressure at port 3 is directly additive to the setting of the valve. Because of this, port 3 may not be useable as a work port in your circuit. If this is a consideration, the 4 port version of this valve may be a solution.
- For DP*C and DP*D port 3 can be blocked to prevent the cartridge from shifting.

Nominal Capacity	Version	Control**	Adjustment Range	Seal
B 30 L/min.	A 2 Position 2-Way Normally Open	L Standard Screw	A 7 - 210 bar	N Buna-N
C 60 L/min.	B 2 Position 2-Way Normally Closed	C Tamper Resistant	B 3,5 - 105 bar	V Viton
	C 2 Position 3-Way Port 1 Blocked	K Handknob	D 2 - 55 bar	
	D 2 Position 3-Way Port 1 Open		E 2 - 25 bar	
			W 10 - 315 bar	

Adjustment Range Options:
 A, B, and W are standard set at 70 bar.
 D Option is standard set at 25 bar.
 E Option is standard set at 14 bar.
 Customer may specify pressure setting.

** See page 162 for information on Control Options

Visit www.sunhydraulics.com for detailed and complete technical information on our full line of products.

2 POSITION, 2-WAY AND 3-WAY, WITH EXTERNAL DRAIN

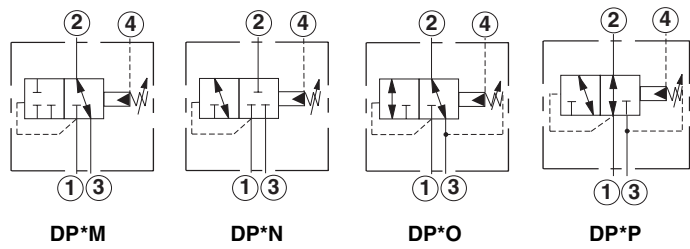
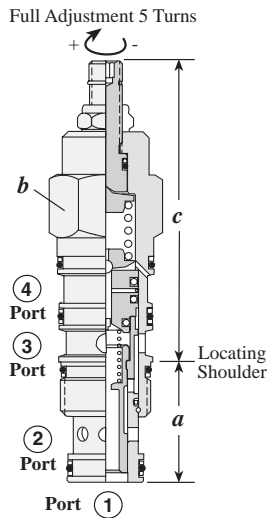

Capacity	Typical Cartridge Model Code	Cavity	Cartridge Dimensions						Installation Torque (Nm)
			a	b	c				
					L	C	K		
30 L/min.	DPBM – LAN	T - 21A	34,9	22,2	79	81	85	40/50	
60 L/min.	DPCM – LAN	T - 22A	34,9	28,6	88	90	94	60/70	

Performance Curves

DPB*

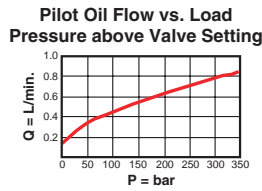
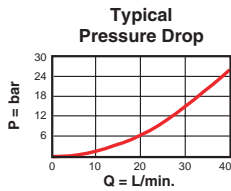

DPC*

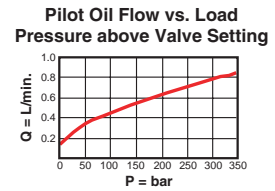
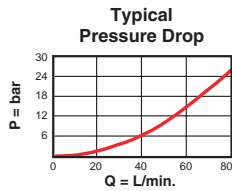

- Maximum operating pressure = 350 bar
- Maximum valve leakage = 16,4 cc/min. at 70 bar
- Control pilot flow at opening = DPBM, DPBN, DPBO, DPBP = 0,11 - 0,16 L/min., DPCM, DPCN, DPCO, DPCP = 0,16 - 0,25 L/min.
- Maximum pressure at port 3 should be limited to 210 bar.
- Pressure at port 4 is directly additive to the setting of the valve.
- Port 3 can be used as a work port.
- Port 4 can be blocked to prevent the cartridge from shifting.

DP ★ ★ - ★ ★ ★

Nominal Capacity	Version	Control**	Adjustment Range	Seal
B 30 L/min.	M 2 Position 2-Way Normally Open	L Standard Screw	A 7 - 210 bar	N Buna-N
C 60 L/min.	N 2 Position 2-Way Normally Closed	C Tamper Resistant	B 3,5 - 105 bar	V Viton
	O 2 Position 3-Way Port 1 Blocked	K Handknob	D 2 - 55 bar	
	P 2 Position 3-Way Port 1 Open		E 2 - 25 bar	
			W 10 - 315 bar	

Adjustment Range Options:
 A, B, and W are standard set at 70 bar.
 D Option is standard set at 25 bar.
 E Option is standard set at 14 bar.
 Customer may specify pressure setting.

** See page 162 for information on Control Options

Visit www.sunhydraulics.com for detailed and complete technical information on our full line of products.

2 POSITION, 2-WAY AND 3-WAY DIRECT ACTING, INTERNAL DRAIN

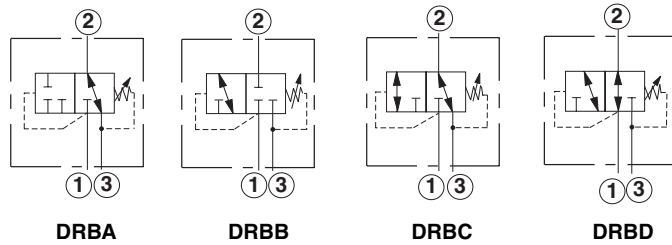
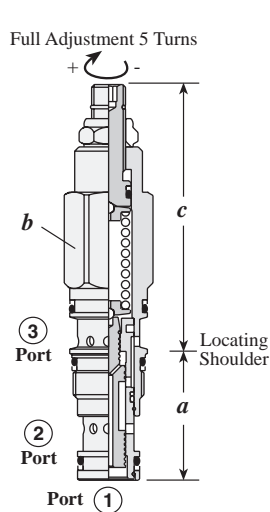

Capacity	Typical Cartridge Model Code	Cavity	Cartridge Dimensions					Installation Torque (Nm)
			a	b	L	C	K	
30 L/min.	DRBA - LAN	T - 11A	34,9	22,2	79	81	85	40/50

Performance Curves

DRBA

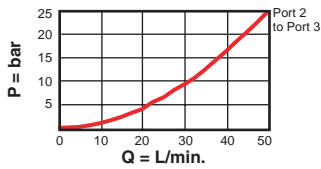

DRBB

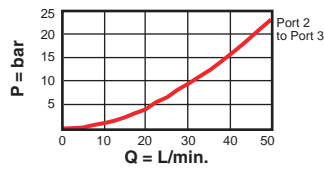

DRBC

Typical Pressure Drop

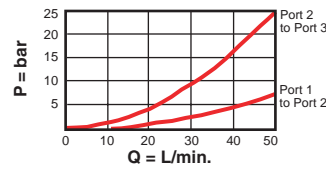

DRBD

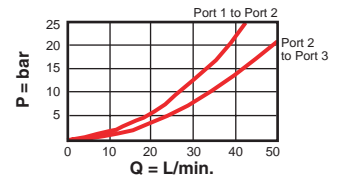

- Maximum operating pressure = 350 bar
- Maximum valve leakage = 32,8 cc/min. at 70 bar
- Maximum pressure at port 3 should be limited to 210 bar.
- Pressure at port 3 is directly additive to the setting of the valve. Because of this, port 3 may not be useable as a work port in your circuit. If this is a consideration, the 4 port version of this valve may be a solution.

Nominal Capacity	Version	Control**	Adjustment Range	Seal
B 30 L/min.	A 2 Position 2-Way Normally Open	L Standard Screw	A 35 - 210 bar	N Buna-N
	B 2 Position 2-Way Normally Closed	C Tamper Resistant	B 14 - 105 bar	V Viton
	C 2 Position 3-Way Port 1 Blocked	K Handknob	D 1,5 - 55 bar	
	D 2 Position 3-Way Port 1 Open		E 1,5 - 25 bar	
			S 1,5 - 14 bar	
			W 50 - 315 bar	

Adjustment Range Options:
 A, B, and W are standard set at 70 bar.
 D Option is standard set at 25 bar.
 E and S are standard set at 14 bar.
 Customer may specify pressure setting.

** See page 162 for information on Control Options

Visit www.sunhydraulics.com for detailed and complete technical information on our full line of products.

2-POSITION, 2-WAY AND 3 WAY, DIRECT ACTING

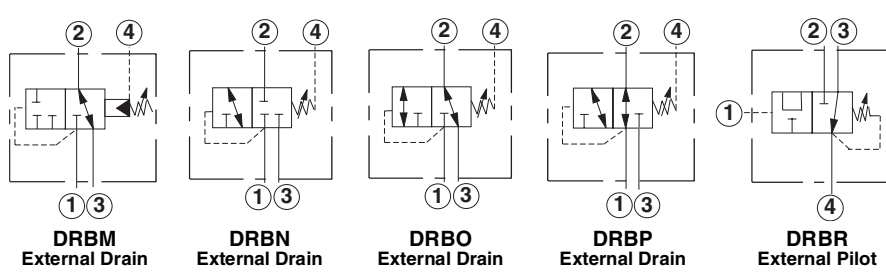
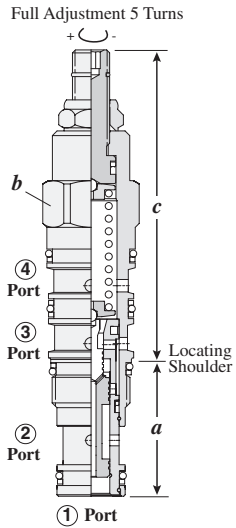

Capacity	Typical Cartridge Model Code	Cavity	Cartridge Dimensions					Installation Torque (Nm)
			a	b	c			
					L	C	K	
30 L/min.	DRBM – LAN	T - 21A	34,9	22,2	79	81	85	40/50
30 L/min.	DRBN – LAN	T - 21A	34,9	22,2	79	81	85	40/50
30 L/min.	DRBO – LAN	T - 21A	34,9	22,2	79	81	85	40/50
30 L/min.	DRBP – LAN	T - 21A	34,9	22,2	79	81	85	40/50
30 L/min.	DRBR – LAN	T - 21A	34,9	22,2	79	81	85	40/50

Performance Curves

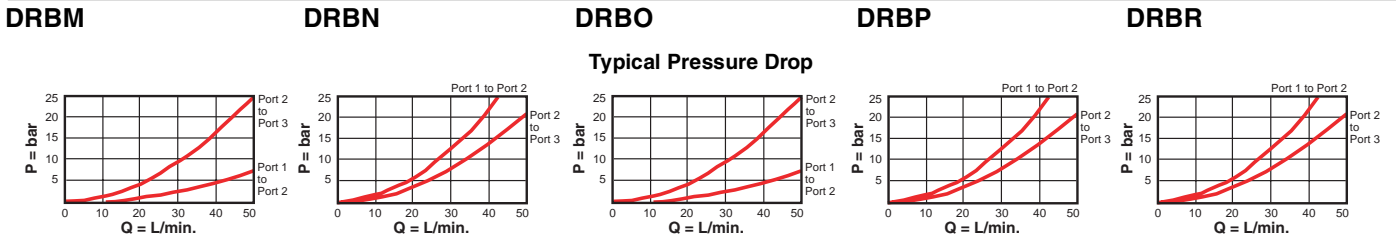

- Maximum operating pressure = 350 bar
- Maximum valve leakage = 32,8 cc/min. at 70 bar
- Maximum pressure at port 3 should be limited to 210 bar.
- DRBM, DRBN, DRBO, DRBP: Port 3 can be used as a work port
- DRBM, DRBN, DRBO, DRBP: Pressure at port 4 is directly additive to the setting of the valve.

Nominal Capacity	Version	Control**	Adjustment Range	Seal
B 30 L/min.	M 2-Position, 2-Way, Normally Open, External Drain	L Standard Screw	A 35 - 210 bar	N Buna-N
	N 2-Position, 2-Way, Normally Closed, External Drain	C Tamper Resistant	B 14 - 105 bar	V Viton
	O 2-Position, 3-Way, Port 1 Blocked, External Drain	K Handknob	N* 4 - 55 bar	
	P 2-Position, 3-Way, Port 1 Open, External Drain		E* 2 - 25 bar	
	R 2-Position, 3-Way, External Pilot*		S* 2 - 14 bar	
			W 50 - 315 bar	

Adjustment Range Options:
 A, B, and W are standard set at 70 bar.
 N Option is standard set at 25 bar.
 E and S are standard set at 14 bar.
 Customer may specify pressure setting.

** See page 162 for information on Control Options

Visit www.sunhydraulics.com for detailed and complete technical information on our full line of products.

2-WAY AND 3-WAY WITH INTEGRAL PILOT CONTROL CAVITY

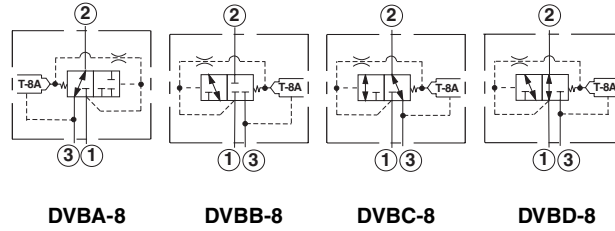
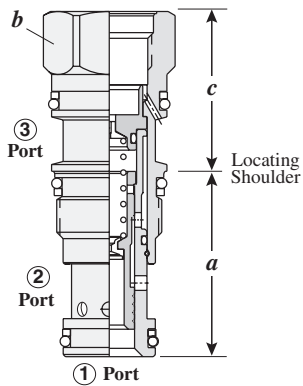

The -8 control option allows the pilot control valve to be incorporated directly into the end of the cartridge via the T-8A cavity. These pilot control cartridges are sold separately and include solenoid, air pilot, and hydraulic pilot operation. See Pilot Control Cartridges on page 121.

Capacity	Typical Cartridge Model Code	Cavity	Cartridge Dimensions			Installation Torque (Nm)
			a	b	c	
28 L/min.	DVBA-8FN	T-11A	35,1	22,2	35,1	45/50
28 L/min.	DVBB-8FN	T-11A	35,1	22,2	35,1	45/50
28 L/min.	DVBC-8FN	T-11A	35,1	22,2	35,1	45/50
28 L/min.	DVBD-8FN	T-11A	35,1	22,2	35,1	45/50

Performance Curves

DV***-8

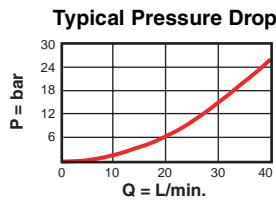

- Maximum operating pressure = 350 bar
- Control pilot flow at opening = DVBA-8, DVBB-8, DVBC-8, DVBD-8 = 0,11 - 0,16 L/min., DVCA-8, DVCB-8, DVCC-8, DVCD-8 = 0,16 - 0,25 L/min.
- Maximum leakage per path = 32,8 cc/min. at 70 bar
- Maximum pressure at port 3 should be limited to 210 bar.
- There must be a pressure source at port 1, relative to port 3, to shift the valve.
- Pressure at port 3 may oppose the opening of the valve. Because of this, port 3 may not be useable as a work port in your circuit. If this is a consideration, the 4 port version of this valve may be a solution.
- The main stage valve should first be installed to the correct torque value followed by the T-8A pilot control section into the main stage valve to its required torque value.

Nominal Capacity	Version	Control**	Adjustment Range	Seal
B 28 L/min.	A 2 Position, 2-Way Normally Open	8 T-8A Cavity in in hex body for pilot operation (Pilot valve to be ordered separately)	F 7 bar	N Buna-N
	B 2 Position, 2-Way Normally Closed			V Viton
	C 2 Position, 3-Way, Port 1 Blocked			
	D 2 Position, 3-Way, Port 1 Open			

** See page 162 for information on Control Options

Visit www.sunhydraulics.com for detailed and complete technical information on our full line of products.

4-PORT, 2-WAY AND 3-WAY WITH INTEGRAL PILOT CONTROL CAVITY

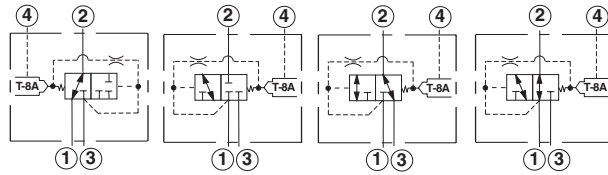
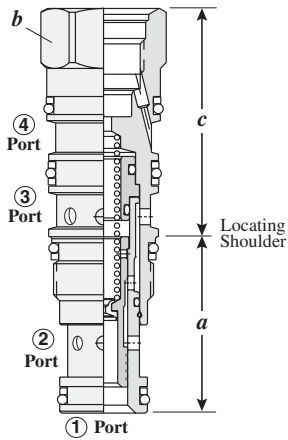

The -8 control option allows the pilot control valve to be incorporated directly into the end of the cartridge via the T-8A cavity. These pilot control cartridges are sold separately and include solenoid, air pilot, and hydraulic pilot operation. See Pilot Control Cartridges on page 121.

DVBM-8 DVBN-8 DVBO-8 DVBP-8

Capacity	Typical Cartridge Model Code	Cavity	Cartridge Dimensions			Installation Torque (Nm)
			a	b	c	
28 L/min.	DVBM – 8FN	T-21A	35,1	22,2	42,9	45/50
28 L/min.	DVBN – 8FN	T-21A	35,1	22,2	42,9	45/50
28 L/min.	DVBO – 8FN	T-21A	35,1	22,2	42,9	45/50
28 L/min.	DVBP – 8FN	T-21A	35,1	22,2	42,9	45/50

Performance Curves

DV☆☆-8

Typical Pressure Drop

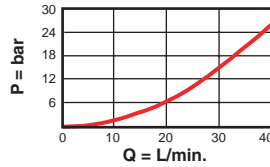

- Maximum operating pressure = 350 bar
- Control pilot flow at opening = DVBM-8, DVBN-8, DVBO-8, DVBP-8 = 0,11 - 0,16 L/min., DVCM-8, DVCN-8, DVCO-8, DVCP-8 = 0,16 - 0,25 L/min.
- Maximum leakage per path = 32,8 cc/min. at 70 bar
- Maximum pressure at port 3 should be limited to 210 bar.
- There must be a pressure source at port 1, relative to port 4, to shift the valve.
- The main stage valve should first be installed to the correct torque value followed by the T-8A pilot control section into the main stage valve to its required torque value.

DV☆☆ - 8☆☆

Nominal Capacity	Version	Control**	Adjustment Range	Seal
B 28 L/min.	M 2 Position, 2-Way Normally Open	8 T-8A Cavity in hex body for pilot operation (Pilot valve to be ordered separately)	F 7 bar	N Buna-N
	N 2 Position, 2-Way Normally Closed			V Viton
	O 2 Position, 3-Way, Port 1 Blocked			
	P 2 Position, 3-Way, Port 1 Open			

** See page 162 for information on Control Options

Visit www.sunhydraulics.com for detailed and complete technical information on our full line of products.



2-POSITION, 2-WAY POPPET, CONTROL 1 TO 2 WITH INTEGRAL PILOT CONTROL CAVITY

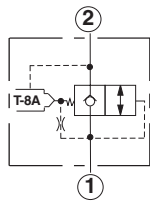
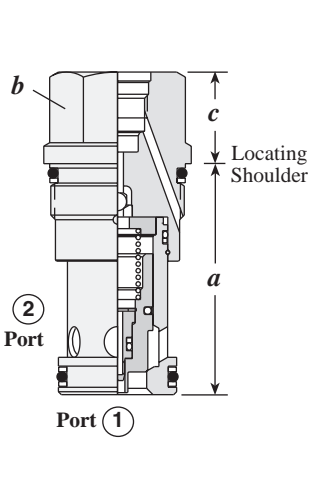

The -8 control option allows the pilot control valve to be incorporated directly into the end of the cartridge via the T-8A cavity. These pilot control cartridges are sold separately and include solenoid, air pilot, and hydraulic pilot operation. See Pilot Control Cartridges on page 121.

Capacity	Typical Cartridge Model Code	Cavity	Cartridge Dimensions			Installation Torque (Nm)
			a	b	c	
60 L/min.	DFCA – 8DN	T - 13A	34,9	22,2	46	40/50
120 L/min.	DFDA – 8DN	T - 5A	41.1	28,6	17,5	60/70
240 L/min.	DFEA – 8DN	T - 16A	62,0	31,8	24,6	200/215
480 L/min.	DFFA – 8DN	T - 18A	79,5	41,3	30,2	465/500

Performance Curves

DFCA-8

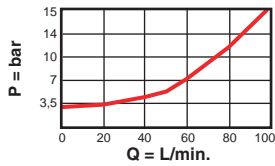

DFDA-8

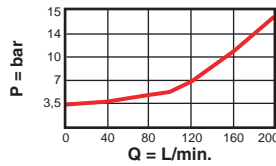

DFEA-8

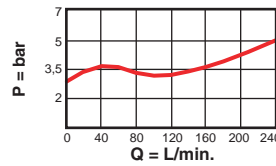

DFFA-8

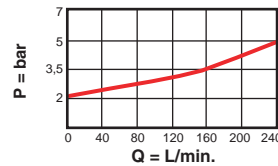

Typical Pressure Drop

- Maximum operating pressure = 350 bar
- The main stage valve should first be installed to the correct torque value followed by the T-8A pilot control section into the main stage valve to its required torque value.
- Main stage leakage less than 0,3 cc/min.

DF ★ A – 8 D ★

Nominal Capacity	Control**	Adjustment Range	Seal
C 60 L/min.	8 T-8A cavity in hex body for pilot operation (Pilot valve to be ordered separately) Options are: • Solenoid Pilot • Air Pilot • Hydraulic Pilot • Manual Control	D 3,5 bar	N Buna-N
D 120 L/min.			V Viton
E 240 L/min.			
F 480 L/min.			

Visit www.sunhydraulics.com for detailed and complete technical information on our full line of products.

2-POSITION, 2-WAY POPPET, CONTROL 2 TO 1 WITH INTEGRAL PILOT CONTROL CAVITY

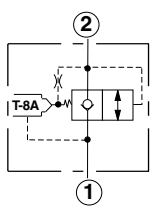
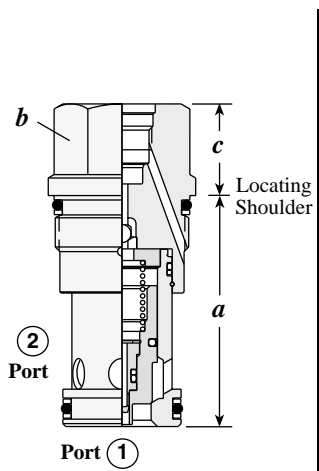

The -8 control option allows the pilot control valve to be incorporated directly into the end of the cartridge via the T-8A cavity. These pilot control cartridges are sold separately and include electro-proportional, solenoid, air pilot, and hydraulic pilot operation. See Pilot Control Cartridges on page 121.

Capacity	Typical Cartridge Model Code	Cavity	Cartridge Dimensions			Installation Torque (Nm)
			a	b	c	
60 L/min.	DFCB – 8DN	T - 13A	34,9	22,2	18	40/50
120 L/min.	DFDB – 8DN	T - 5A	41,1	28,6	18	60/70
240 L/min.	DFEB – 8DN	T - 16A	61,9	31,8	25	200/215

Performance Curves

DFCB-8

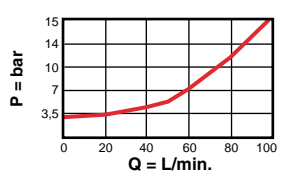

DFDB-8

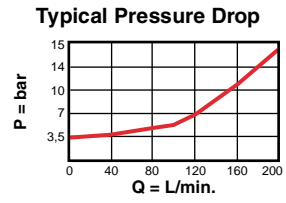

DFEB-8

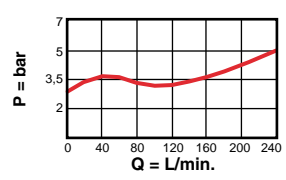

- Main stage leakage less than 5 drops/min. Maximum operating pressure = 350 bar
- The main stage valve should first be installed to the correct torque value followed by the T-8A pilot control section into the main stage valve to its required torque value.
- Main stage leakage less than 0,3 cc/min.

DF ★ B – 8 D ★

Nominal Capacity	Control	Adjustment Range	Seal
C 60 L/min.	T-8A Pilot Cavity Pilot Stage Control to be ordered separately. Options are: • Solenoid Pilot • Air Pilot • Hydraulic Pilot • Manual Control	D Bias Spring 3,5 bar	N Buna-N
D 120 L/min.			V Viton
E 240 L/min.			

Visit www.sunhydraulics.com for detailed and complete technical information on our full line of products.



3-POSITION, 4-WAY SPRING CENTERED

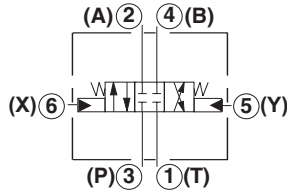
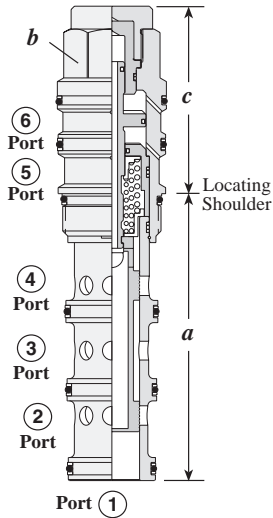

Capacity	Typical Cartridge Model Code	Cavity	Cartridge Dimensions			Installation Torque (Nm)
			a	b	c	
40 L/min.	DCCC – XCN	T - 61A	84,8	22,2	50	40/50
80 L/min.	DCDC – XCN	T - 62A	92,2	28,6	59	60/70
160 L/min.	DCEC – XCN	T - 63A	114,4	31,8	73	200/215
320 L/min.	DCFC – XCN	T - 64A	139,7	41,3	92	465/500

Performance Curves

DCCC

DCDC

DCEC

DCFC

Typical Pressure Drop

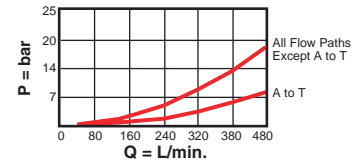
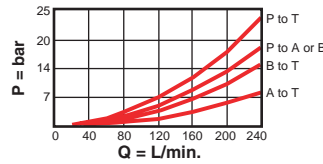
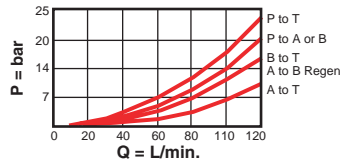
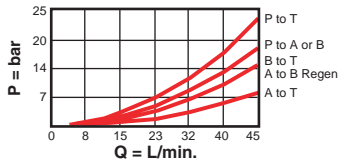

- Maximum operating pressure = 350 bar
- Maximum leakage per path = 2 in³/min. at 1000 psi
- Pilot volume for complete shift = DCCC: 0,33 cc/min., DCDC: 0,98 cc/min., DCEC: 2,8 cc/min., CFC: 6,9 cc/min.
- Minimum pilot pressure required to shift valve = DCCC: 12 bar, DCDC: 10,5 bar, DCEC, DCFC: 9 bar
- All ports will accept 350 bar, including the x and y pilot ports (port 5 and port 6).

DC * C - X * *

Nominal Capacity	Spool Configuration Capacity (L/min.)				Seal	
	C	D	E	F		
C 40 L/min.		95,0	189,0	378,0	756,0	N Buna-N
D 80 L/min.		38,0	91,0	151,0	378,0	V Viton
E 160 L/min.		38,0	95,0	151,0	378,0	
F 320 L/min.		38,0	189,0	378,0	756,0	
		45,0	189,0	378,0	756,0	
		27,0	42,0	95,0	189,0	
		27,0	45,0	95,0	189,0	
		27,0	57,0	113,0	227,0	
		38,0	189,0	284,0	567,0	
		38,0	---	284,0	---	

Typical switching pilot pressure differential between pilot ports 5 and 6 is 14 bar.

Visit www.sunhydraulics.com for detailed and complete technical information on our full line of products.

2-POSITION, 4-WAY DETENTED

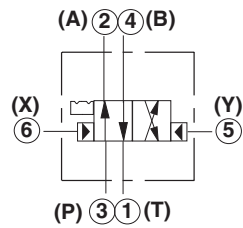
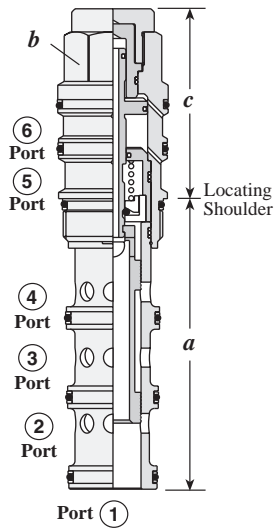

Capacity	Typical Cartridge Model Code	Cavity	Cartridge Dimensions			Installation Torque (Nm)
			a	b	c	
40 L/min.	DCCD - XCN	T - 61A	84,8	22,2	50	40/50
80 L/min.	DCDD - XCN	T - 62A	92,2	28,6	59	60/70
160 L/min.	DCED - XCN	T - 63A	114,4	31,8	73	200/215
320 L/min.	DCFD - XCN	T - 64A	139,7	41,3	92	465/500

Performance Curves

DCCD

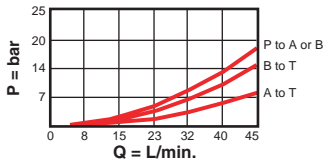

DCDD

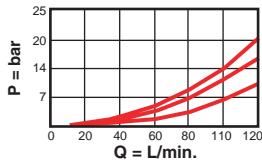

DCED

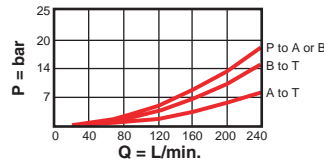

DCFD

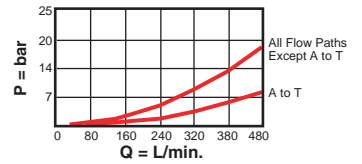

- Maximum operating pressure = 350 bar
- Maximum leakage per path = 2 in³/min. at 1000 psi
- Pilot volume for complete shift = DCCD: 0,82 cc/min., DCDD: 2,0 cc/min., DCED: 5,6 cc/min., DCFD: 14,0 cc/min.
- Minimum pilot pressure required to shift valve = 3 bar
- All ports will accept 350 bar, including the x and y pilot ports (port 5 and port 6).

DC * D - X * *

Nominal Capacity	Spool Configuration Capacity (L/min.)				Seal	
	C	D	E	F		
C 40 L/min.		42,0	83,0	170,0	340,0	N Buna-N
D 80 L/min.		38,0	76,0	151,0	302,0	V Viton
E 160 L/min.		49,0	151,0	302,0	567,0	
F 320 L/min.						

Typical switching pilot pressure differential between pilot ports 5 and 6 is 14 bar.

Visit www.sunhydraulics.com for detailed and complete technical information on our full line of products.

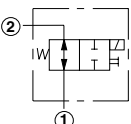
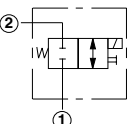
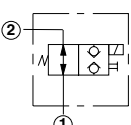
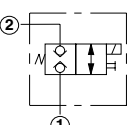
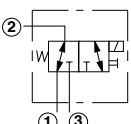
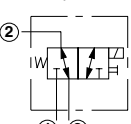
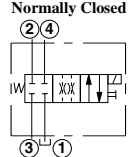
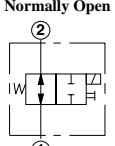
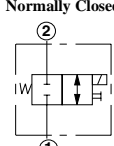
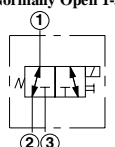
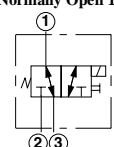

Solenoid Operated Cartridge Valves

		<i>Cartridge Type</i>	<i>Page</i>
Normally Open 	Normally Closed 	2-position, 2-way Spool Directional Valve	114
Normally Open 	Normally Closed 	Direct Acting, 2-position, 2-way Poppet Directional Valve	115
Normally Open 	Normally Closed 	2-position, 3-way Spool Directional Valve	116
Normally Closed 		2-position, 4-way Spool Directional Valve	117
Normally Open 	Normally Closed 	2-position, 2-way Spool Directional Valve – Pilot Capacity	118
Normally Open 1-3 	Normally Open 1-2 	2-position, 3-way Spool Directional Valve – Pilot Capacity	119

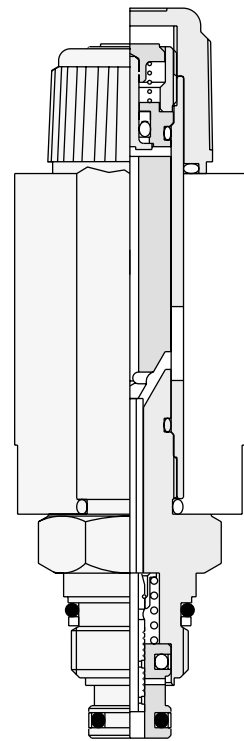

Solenoid Operated Cartridge Valves

2-POSITION, 2-WAY SPOOL DIRECTIONAL VALVE

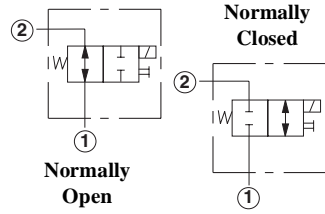
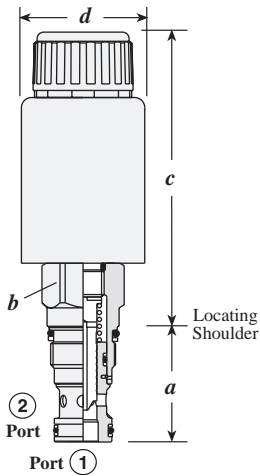

Nominal Capacity	Typical Cartridge Model Code	Cavity	Cartridge Dimensions				Installation Torque (Nm)
			a	b	c	d	
40 L/min.	DLDA – MHN	T - 13A	34,9	22,4	90	38	40/50

Performance Curves

DLDA-M**

Valve Performance Limits at 10% Undervoltage and Stabilized Coil Temp.

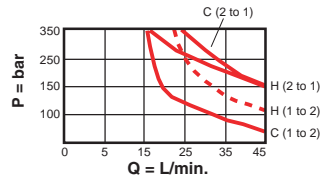

Typical Performance Pressure Differential vs. Flow

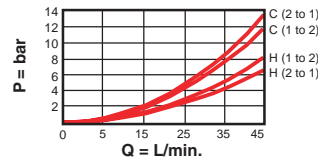

- Maximum operating pressure = 350 bar**
- Maximum Leakage at 32 cSt = 81,9 cc/min. at 210 bar
- Switching frequency = 15000 cycles/hr
- Proper installation of solenoid valves requires an extra deep socket to clear the solenoid tube. Sockets are available from Snap On tools (P/N SIML280) or Sun Hydraulics (P/N 998-100-006). See www.sunhydraulics.com for details.

**For valves produced before January 1, 2004 (date code A041), the maximum operating pressure is 350 bar at port 2 and 250 bar at port 1.
NOTE: While the valve will operate reliably with pressures up to 350 bar at Port 1, solenoid tube fatigue life is reduced.

DLDA - * * * - * * *

<p>Nominal Capacity</p> <p>D 40 L/min.</p>	<p>Control</p> <p>M Manual Override</p> <p>X No Manual Override</p>	<p>Spool Configuration</p> <p>H Normally Open</p> <p>C Normally Closed</p> <p>Seal</p> <p>N Buna-N</p> <p>V Viton</p>	<p>Coil Configuration*</p> <p>ISO/DIN</p> <p>212 12 VDC</p> <p>224 24 VDC</p> <p>211 115 VAC</p> <p>223 230 VAC</p> <p>AMP® Junior Timer</p> <p>612 12 VDC</p> <p>624 24 VDC</p> <p>Twin Lead</p> <p>712 12 VDC</p> <p>724 24 VDC</p> <p>Deutsch</p> <p>912 12 VDC</p> <p>924 24 VDC</p> <p>948 48 VDC</p> <p>Metri-Pack</p> <p>812 12 VDC</p> <p>824 24 VDC</p> <p>Twin Spade</p> <p>524 24 VDC</p>
--	--	---	---

Maximum Leakage (cc/min. at 210 bar at 32 cSt oil) = 80
Power (Watts) = 22
Operating Voltage Tolerance = ± 10%
Typical response Time (ms) = 50

* See page 167 for Solenoid Connector Options

Visit www.sunhydraulics.com for detailed and complete technical information on our full line of products.

Solenoid Operated Cartridge Valves

DIRECT ACTING, 2-POSITION, 2-WAY POPPET DIRECTIONAL VALVE

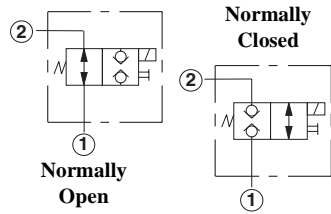
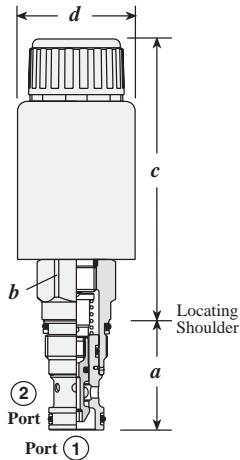

Nominal Capacity	Typical Cartridge Model Code	Cavity	Cartridge Dimensions				Installation Torque (Nm)
			a	b	c	d	
40 L/min.	DTDA - MHN	T - 13A	34,9	22,4	90	38	40/50

Performance Curves

DTDA-M*N

Valve Performance Limits at 10% Undervoltage and Stabilized Coil Temperature

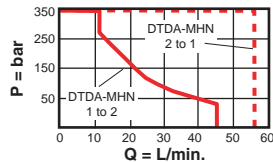
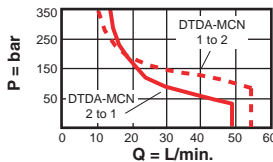

Typical Performance Pressure Differential vs. Flow

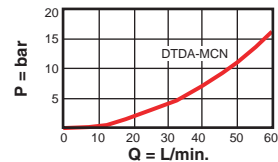
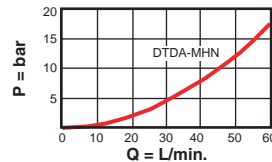

- Maximum operating pressure = 350 bar**
- Maximum Leakage at 32 cSt = 10 drops/min.
- Switching frequency = 15000 cycles/hr.
- Proper installation of solenoid valves requires an extra deep socket to clear the solenoid tube. Sockets are available from Snap On tools (P/N SIML280) or Sun Hydraulics (P/N 998-100-006). See www.sunhydraulics.com for details.

** For valves produced before January 1, 2004 (date code A041), the maximum operating pressure is 350 bar at port 2 and 250 bar at port 1. NOTE: While the valve will operate reliably with pressures up to 350 bar at Port 1, solenoid tube fatigue life is reduced.

DTDA - * * * - * * *

<p>Nominal Capacity</p> <p>D 40 L/min.</p>	<p>Control</p> <p>M Manual Override</p> <p>X No Manual Override</p>	<p>Spool Configuration</p> <p>H Normally Open</p> <p>C Normally Closed</p> <p>Seal</p> <p>N Buna-N</p> <p>V Viton</p>	<p>Coil Configuration*</p> <p>ISO/DIN</p> <p>212 12 VDC</p> <p>224 24 VDC</p> <p>211 115 VAC</p> <p>223 230 VAC</p> <p>AMP® Junior Timer</p> <p>612 12 VDC</p> <p>624 24 VDC</p> <p>Twin Lead</p> <p>712 12 VDC</p> <p>724 24 VDC</p> <p>Deutsch</p> <p>912 12 VDC</p> <p>924 24 VDC</p> <p>948 48 VDC</p> <p>Metri-Pack</p> <p>812 12 VDC</p> <p>824 24 VDC</p> <p>Twin Spade</p> <p>524 24 VDC</p>
--	--	--	---

Power (Watts) = 22
 Operating Voltage Tolerance = ± 10%
 Typical response Time (ms) = 50

* See page 167 for Solenoid Connector Options

Visit www.sunhydraulics.com for detailed and complete technical information on our full line of products.

Solenoid Operated Cartridge Valves

2-POSITION, 3-WAY SPOOL DIRECTIONAL VALVE

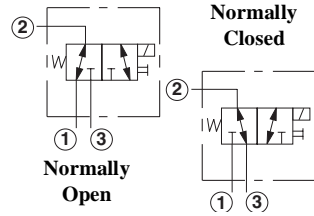
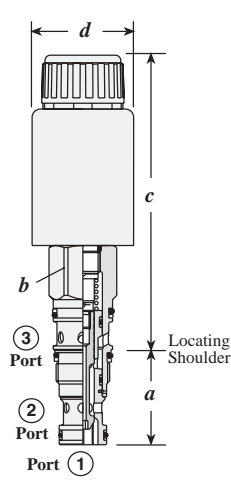

Nominal Capacity	Typical Cartridge Model Code	Cavity	Cartridge Dimensions				Installation Torque (Nm)
			a	b	c	d	
40 L/min.	DMDA – MNN	T - 11A	34,9	22,4	109	38	40/50

Performance Curves

DMDA-MNN

Valve Performance Limits at 10% Undervoltage and Stabilized Coil Temperature

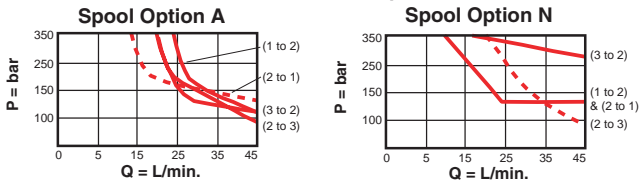

Typical Performance Pressure Differential vs. Flow

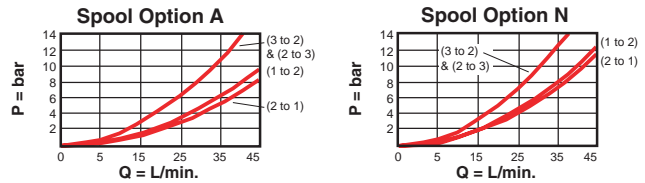

- Maximum operating pressure = 350 bar**
- Maximum Leakage at 32 cSt = 81,9 cc/min. @ 210 bar
- Switching frequency = 15000 cycles/hr
- Proper installation of solenoid valves requires an extra deep socket to clear the solenoid tube. Sockets are available from Snap On tools (P/N SIML280) or Sun Hydraulics (P/N 998-100-006). See www.sunhydraulics.com for details.

**For valves produced before January 1, 2004 (date code A041), the maximum operating pressure is 350 bar at ports 2 and 3 and 250 bar at port 1.
NOTE: While the valve will operate reliably with pressures up to 350 bar at Port 1, solenoid tube fatigue life is reduced.

D M D A - * * * - * * *

Nominal Capacity	Control	Spool Configuration	Coil Configuration*
D 40 L/min.	M Manual Override	A Normally Open Ports 2 to 1	ISO/DIN
	X No manual Override	N Normally Open Ports 2 to 3	212 12 VDC
		Seal	224 24 VDC
		N Buna-N	211 115 VAC
		V Viton	223 230 VAC
			AMP® Junior Timer
			612 12 VDC
			624 24 VDC
			Twin Lead
			712 12 VDC
			724 24 VDC
			Deutsch
			912 12 VDC
			924 24 VDC
			948 48 VDC
			Metri-Pack
			812 12 VDC
			824 24 VDC
			Twin Spade
			524 24 VDC

Maximum Leakage (cc/min. at 210 bar at 32 cSt oil) = 80
Power (Watts) = 22
Operating Voltage Tolerance = ± 10%
Typical response Time (ms) = 30-50

* See page 167 for Solenoid Connector Options

Visit www.sunhydraulics.com for detailed and complete technical information on our full line of products.

Solenoid Operated Cartridge Valves

2-POSITION, 4-WAY SPOOL DIRECTIONAL VALVE

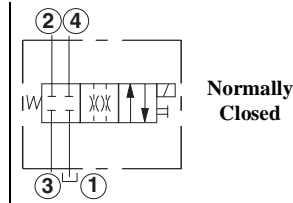
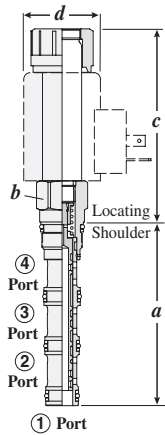

Nominal Capacity	Typical Cartridge Model Code	Cavity	Cartridge Dimensions				Installation Torque (Nm)
			a	b	c	d	
28-45 L/min.	DNDA - MCN	T - 31A	34,9	22,4	90	38	40/50

Performance Curves

DNDA-MCN

Valve Performance Limits at 10% Undervoltage and Stabilized Coil Temperature

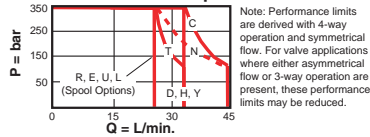

Typical Performance Pressure Differential vs. Flow

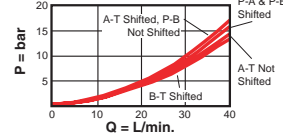

- Maximum operating pressure = 350 bar**
- Maximum Leakage at 32 cSt = 163 cc/min. at 210 bar
- Switching frequency = 15000 cycles/hr
- Proper installation of solenoid valves requires an extra deep socket to clear the solenoid tube. Sockets are available from Snap On tools (P/N SIML280) or Sun Hydraulics (P/N 998-100-006). See www.sunhydraulics.com for details.

**For valves produced before January 1, 2004 (date code A041), the maximum operating pressure is 350 bar at ports 2, 3 and 4 and 250 bar at port 1. NOTE: While the valve will operate reliably with pressures up to 350 bar at Port 1, solenoid tube fatigue life is reduced.

DNDA - * * * - * * *

Nominal Capacity	Control	Spool Configuration	Coil Configuration*
D 28-45 L/min.	M Manual Override	C	ISO/DIN
	X No manual Override	D	212 12 VDC
		E	224 24 VDC
		H	211 115 VAC
		L	223 230 VAC
		N	AMP® Junior Timer
		R	612 12 VDC
		T	624 24 VDC
		U	Twin Lead
		Y	712 12 VDC
			724 24 VDC
			Deutsch
			912 12 VDC
			924 24 VDC
			948 48 VDC
			Metri-Pack
			812 12 VDC
			824 24 VDC
			Twin Spade
			524 24 VDC
		Seal	
		N Buna-N	
		V Viton	

Maximum Leakage (cc/min. at 210 bar at 32 cSt oil) = 163
 Power (Watts) = 22
 Operating Voltage Tolerance = ± 10%
 Typical response Time (ms) = 30-50

* See page 167 for Solenoid Connector Options

Visit www.sunhydraulics.com for detailed and complete technical information on our full line of products.

Solenoid Operated Cartridge Valves

2-POSITION, 2-WAY SPOOL DIRECTIONAL VALVE – PILOT CAPACITY

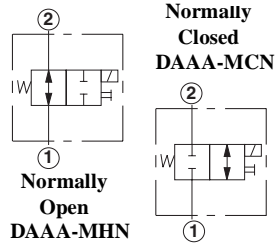
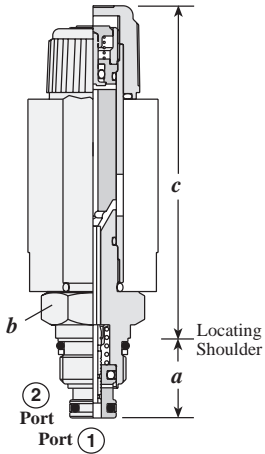

Nominal Capacity	Typical Cartridge Model Code	Cavity	Cartridge Dimensions					Installation Torque (Nm)
			a	b	c		d	
1 L/min.	DAAA – MCN	T - 8A	19,1	22,4	75	80	31	35/40
1 L/min.	DAAA – MHN	T - 8A	19,1	22,4	75	80	31	35/40
1 L/min.	DAAC – MCN	T - 8A	19,1	22,4	75	80	31	35/40
1 L/min.	DAAC – MHN	T - 8A	19,1	22,4	75	80	31	35/40

Performance Curves

DAA*-M*N

Pressure vs. Flow

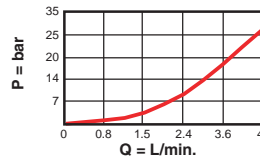

- Maximum operating pressure = 350 bar
- Maximum Leakage at 32 cSt = 10 drops/min.
- Switching frequency = 15000 cycles/hr.
- Cartridge can be installed directly into a cavity in some Sun pilot operated and ventable cartridges to provide electrically operated pilot control functions.
- Proper installation of solenoid valves requires an extra deep socket to clear the solenoid tube. Sockets are available from Snap On tools (P/N SIML280) or Sun Hydraulics (P/N 998-100-006). See www.sunhydraulics.com for details.

D A A * - * * * - * * *

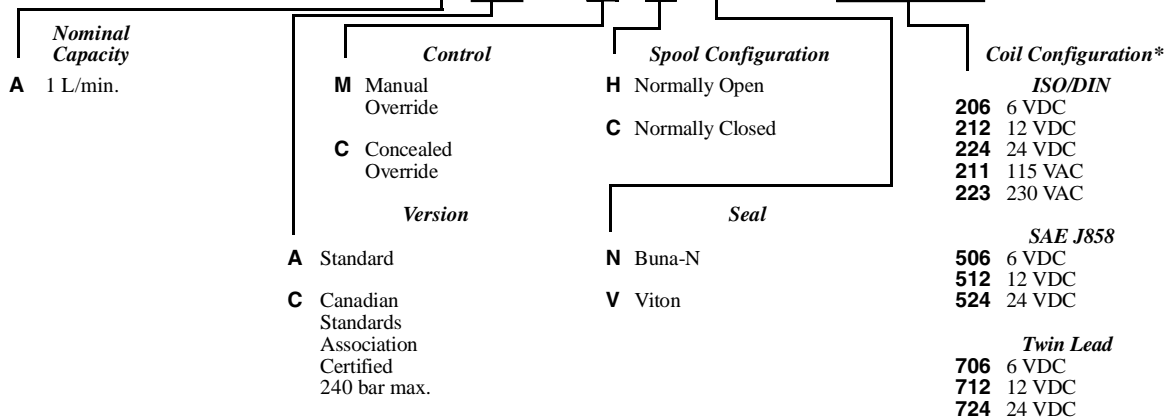

Diameter Effective Orifice (mm) = 1,1
 Operating Voltage Tolerance = ± 10%
 Power (Watts) = 12
 Typical response Time (ms) = 30

* See page 167 for Solenoid Connector Options

Visit www.sunhydraulics.com for detailed and complete technical information on our full line of products.

Solenoid Operated Cartridge Valves

2-POSITION, 3-WAY SPOOL DIRECTIONAL VALVE – PILOT CAPACITY

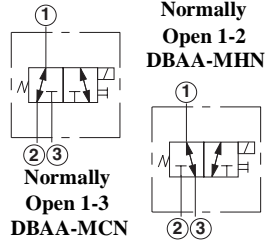
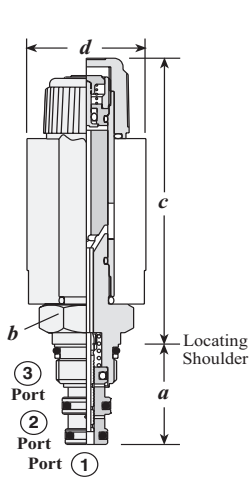

Nominal Capacity	Typical Cartridge Model Code	Cavity	Cartridge Dimensions				Installation Torque (Nm)
			a	b	M	C	
1 L/min.	DBAA – MCN	T - 9A	27,7	22,4	75	80	35/40
1 L/min.	DBAA – MHN	T - 9A	27,7	22,4	75	80	35/40
1 L/min.	DBAC – MCN	T - 9A	27,7	22,4	75	80	35/40
1 L/min.	DBAC – MHN	T - 9A	27,7	22,4	75	80	35/40

Performance Curves

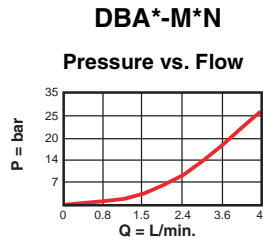

- Maximum operating pressure = 350 bar
- Maximum Leakage at 32 cSt = 10 drops/min.
- Switching frequency = 15000 cycles/hr
- Proper installation of solenoid valves requires an extra deep socket to clear the solenoid tube. Sockets are available from Snap On tools (P/N SIML280) or Sun Hydraulics (P/N 998-100-006). See www.sunhydraulics.com for details.

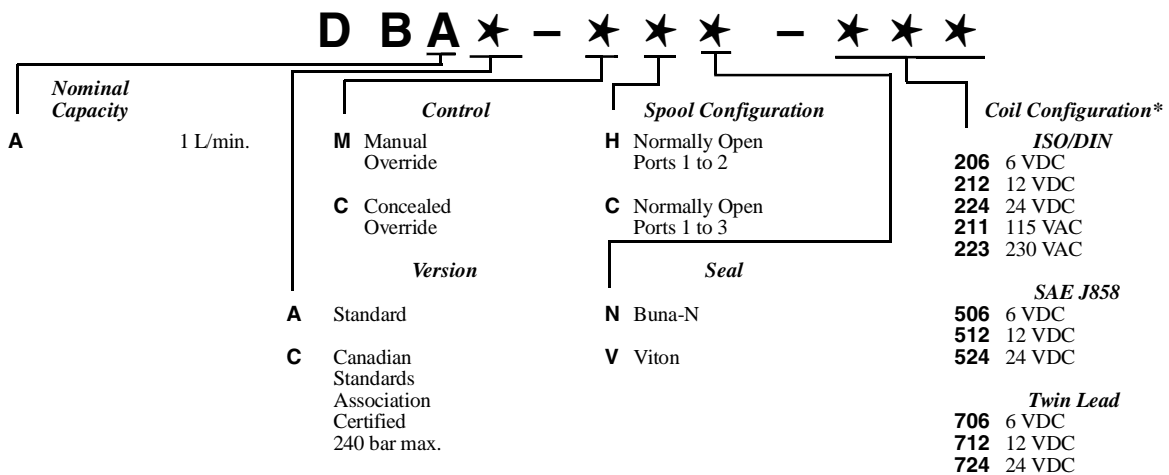

Diameter Effective Orifice (mm) = 1,1
 Operating Voltage Tolerance = ± 10%
 Power (Watts) = 12
 Typical response Time (ms) = 30

* See page 167 for Solenoid Connector Options

Visit www.sunhydraulics.com for detailed and complete technical information on our full line of products.



NOTES

Pilot Control Valves

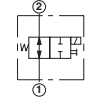
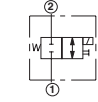
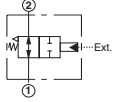
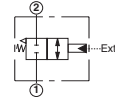
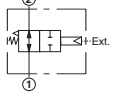
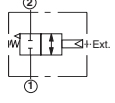
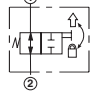
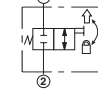
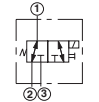
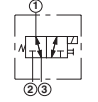
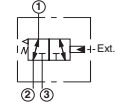
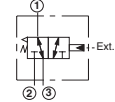
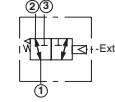
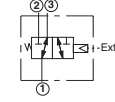
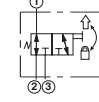
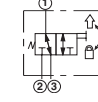
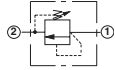
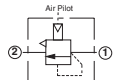
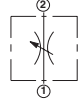
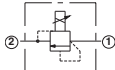
		<i>Cartridge Type</i>	<i>Page</i>
Normally Open	Normally Closed	2-position 2-way, Spool Directional Valve - Pilot Capacity	122
			
Normally Closed	Normally Open	Hydraulically Operated, 2-position 2-way, Spool Directional Valve - Pilot Capacity	123
			
Normally Open	Normally Closed	Air-operated, 2-position 2-way, Spool Directional Valve - Pilot Capacity	124
			
Normally Open	Normally Closed	Manually Operated, 2-position 2-way, Spool Directional Valve - Pilot Capacity	125
			
Normally Open 1-3	Normally Open 1-2	2-position 3-way, Spool Directional Valve - Pilot Capacity	126
			
Normally Open 1-2	Normally Closed 1-3	Hydraulically Operated, 2-position 3-way, Spool Directional Valve - Pilot Capacity	127
			
Normally Closed 1-3	Normally Open 1-2	Air-operated, 2-position 3-way, Spool Directional Valve - Pilot Capacity	128
			
Normally Open	Normally Closed	Manually Operated, 2-position 3-way, Spool Directional Valve - Pilot Capacity	129
			
		Direct Acting, Adjustable Pilot Relief	130
		Air-controlled, Directing Acting Pilot Relief	131
		Fully Adjustable Needle Valve - Pilot Capacity	132
		Electro-proportional Pilot Relief	133

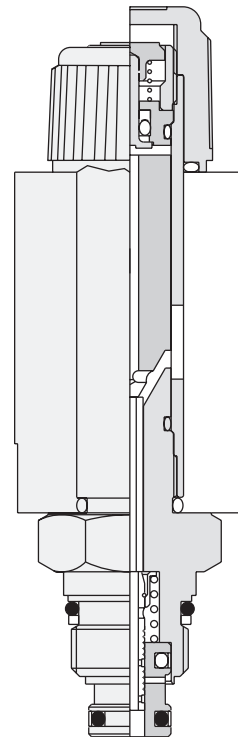

2-POSITION, 2-WAY SPOOL DIRECTIONAL VALVE – PILOT CAPACITY

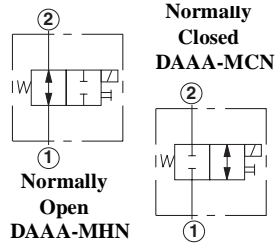
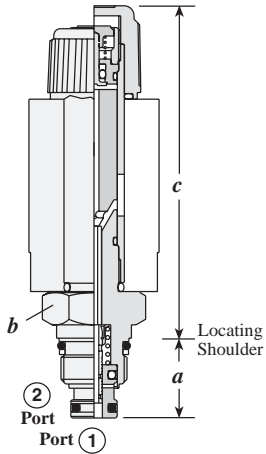

Capacity	Typical Cartridge Model Code	Cavity	Cartridge Dimensions				Installation Torque (Nm)	
			a	b	c			d
1 L/min.	DAAA – MCN	T - 8A	19,1	22,4	75	80	31	35/40
1 L/min.	DAAA – MHN	T - 8A	19,1	22,4	75	80	31	35/40
1 L/min.	DAAC – MCN	T - 8A	19,1	22,4	75	80	31	35/40
1 L/min.	DAAC – MHN	T - 8A	19,1	22,4	75	80	31	35/40

Performance Curves

DAA*-M*N

Pressure vs. Flow

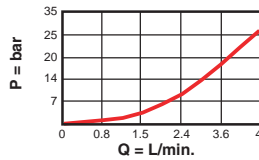

- Maximum operating pressure = 350 bar
- Maximum leakage at 32 cSt = 10 drops/min. at 350 bar
- Switching frequency = 15000 cycles/hour
- Cartridge can be installed directly into a cavity in some Sun pilot operated and ventable cartridges to provide electrically operated pilot control functions.
- Proper installation of solenoid valves requires an extra deep socket to clear the solenoid tube. Sockets are available from Snap On tools (P/N SIML280) or Sun Hydraulics (P/N 998-100-006). See www.sunhydraulics.com for details.

D A A A – M * * – * * *

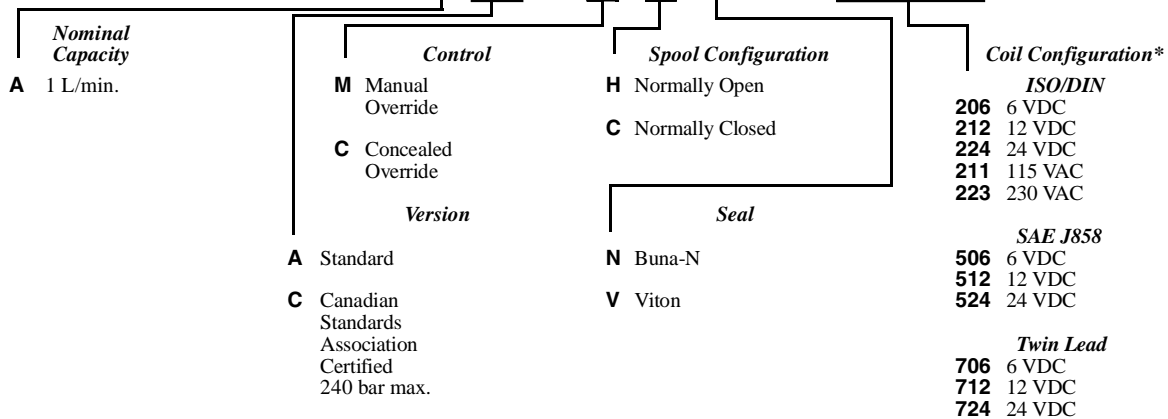

* See page 167 for Solenoid Connector Options

Maximum Leakage (drops/min. at 350 bar at 32 cSt / 43° C) = 10
 Diameter Effective Orifice (mm) = 1,1
 Operating Voltage Tolerance = ± 20%

Power (Watts) = 12
 Typical response Time (ms) = 30

Visit www.sunhydraulics.com for detailed and complete technical information on our full line of products.

HYDRAULICALLY OPERATED, 2-POSITION 2-WAY, SPOOL DIRECTIONAL VALVE - PILOT CAPACITY

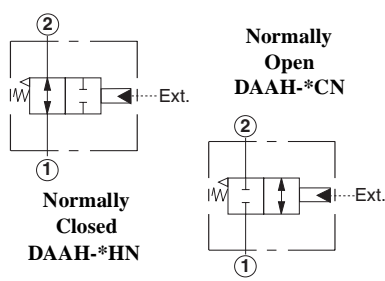
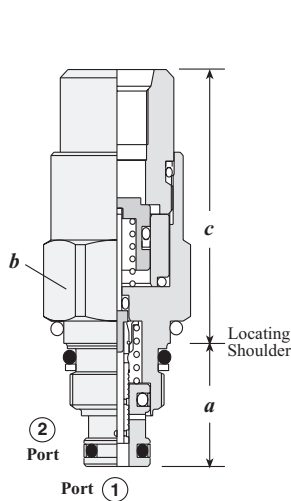

Capacity	Typical Cartridge Model Code	Cavity	Cartridge Dimensions			Installation Torque (Nm)
			a	b	c	
1 L/min.	DAAH - BCN	T - 8A	19,1	22,4	43	35/40

Performance Curves

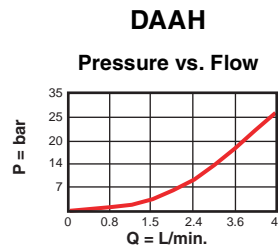

- Maximum operating pressure = 350 bar
- Maximum leakage at 32 cSt = 0,6 cc/min at 350 bar.
- Minimum pilot pressure to operate = 14 bar
- All ports will accept 350 bar including the pilot control port.
- The preferred flow path through the valve is port 2 to port 1.
- The main stage valve should first be installed to the correct torque value followed by the T-8A pilot control section into the main stage valve to its required torque value.

DA A H - * * *

Nominal Capacity	Pilot Port	Spool Configuration	Seal
A 1 L/min.	A 1/8-27 NPTF	H Normally Open	N Buna-N
	B SAE-4	C Normally Closed	V Viton
	D 1/8-28 BSPP		

Visit www.sunhydraulics.com for detailed and complete technical information on our full line of products.

AIR-OPERATED, 2-POSITION 2-WAY, SPOOL DIRECTIONAL VALVE - PILOT CAPACITY

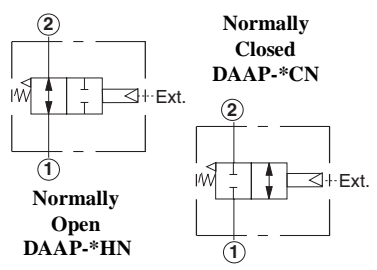
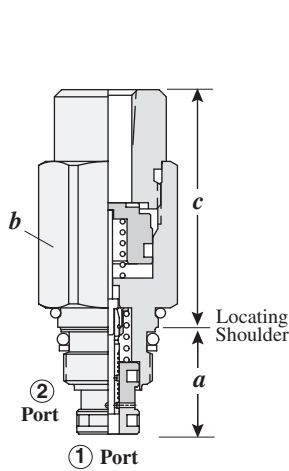

Capacity	Typical Cartridge Model Code	Cavity	Cartridge Dimensions			Installation Torque (Nm)
			a	b	c	
1 L/min.	DAAP – FCN	T - 8A	19,1	22,2	42,2	35/40

Performance Curves

DAAP

Pressure vs. Flow

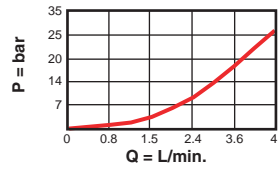

- Maximum operating pressure = 350 bar
- Maximum leakage at 32 cSt = 0,6 cc/min. at 350 bar
- Maximum pilot pressure = 5 bar
- Minimum pilot pressure to operate = 1,5 bar + port 1 pressure/7 bar
- All ports will accept 350 bar with the exception of the pilot port which accepts 35 bar maximum.
- The preferred flow path through the valve is port 2 to port 1.
- The main stage valve should first be installed to the correct torque value followed by the T-8A pilot control section into the main stage valve to its required torque value.

DAAP - * * *

Nominal Capacity	Pilot Port	Spool Configuration	Seal
A 1 L/min.	E SAE-4	H Normally Open	N Buna-N
	F 1/8-27 NPTF	C Normally Closed	V Viton
	P 1/8-28 BSPP		

Visit www.sunhydraulics.com for detailed and complete technical information on our full line of products.

MANUALLY OPERATED, 2-POSITION 2-WAY, SPOOL DIRECTIONAL VALVE - PILOT CAPACITY

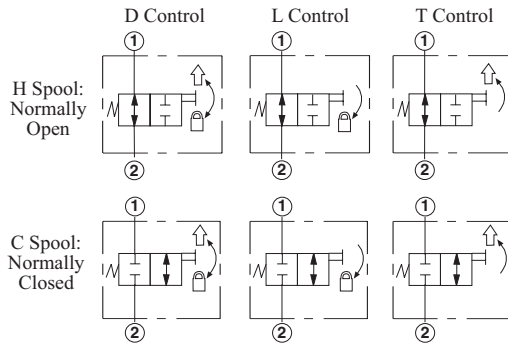
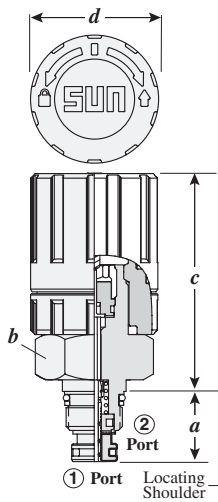

↑ = Twist (Momentary)
 ☒ = Lock (Detent)

Capacity	Typical Cartridge Model Code	Cavity	Cartridge Dimensions				Installation Torque (Nm)
			a	b	c	d	
1 L/min.	DAAM - TCN	T-8A	19,1	28,6	61	35,6	35/40

Performance Curves

DAAM

Pressure vs. Flow

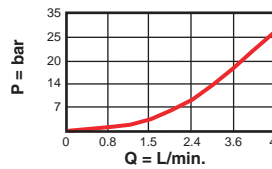

- Maximum operating pressure = 350 bar
- Maximum leakage at 32 cSt = 0,6 cc/min. at 350 bar
- The preferred flow path through the valve is port 2 to port 1.
- The main stage valve should first be installed to the correct torque value followed by the T-8A pilot control section into the main stage valve to its required torque value.

DAAM - ★★

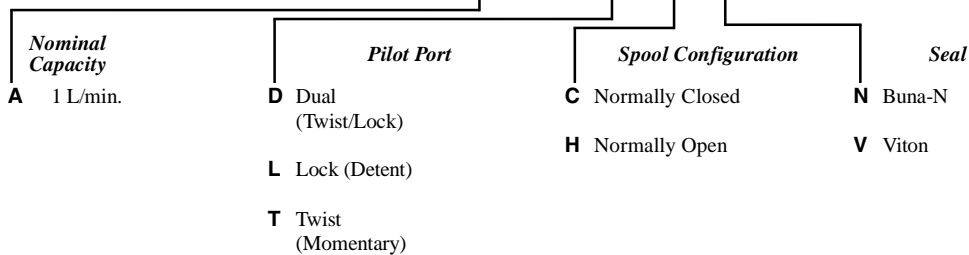

NOTE: Designed for 10,000 cycles of operation maximum under normal conditions.

Visit www.sunhydraulics.com for detailed and complete technical information on our full line of products.



2-POSITION, 3-WAY SPOOL DIRECTIONAL VALVE – PILOT CAPACITY

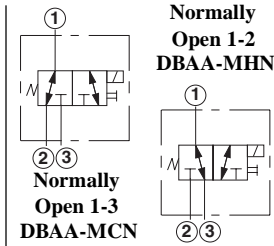
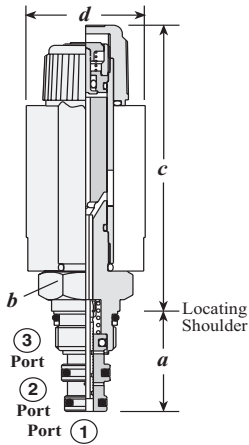

Capacity	Typical Cartridge Model Code	Cavity	Cartridge Dimensions				Installation Torque (Nm)
			a	b	M	C	
1 L/min.	DBAA – MCN	T - 9A	27,7	22,4	75	80	35/40
1 L/min.	DBAA – MHN	T - 9A	27,7	22,4	75	80	35/40
1 L/min.	DBAC – MCN	T - 9A	27,7	22,4	75	80	35/40
1 L/min.	DBAC – MHN	T - 9A	27,7	22,4	75	80	35/40

Performance Curves

DBA*-M*N

Pressure vs. Flow

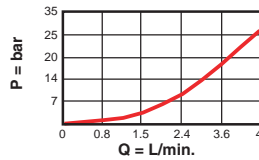

- Maximum operating pressure = 350 bar
- Maximum leakage at 32 cSt = 0,6 cc/min. at 350 bar
- Switching frequency = 15000 cycles/hour
- Proper installation of solenoid valves requires an extra deep socket to clear the solenoid tube. Sockets are available from Snap On tools (P/N SIML280) or Sun Hydraulics (P/N 998-100-006). See www.sunhydraulics.com for details.

D B A A – M * * – * * *

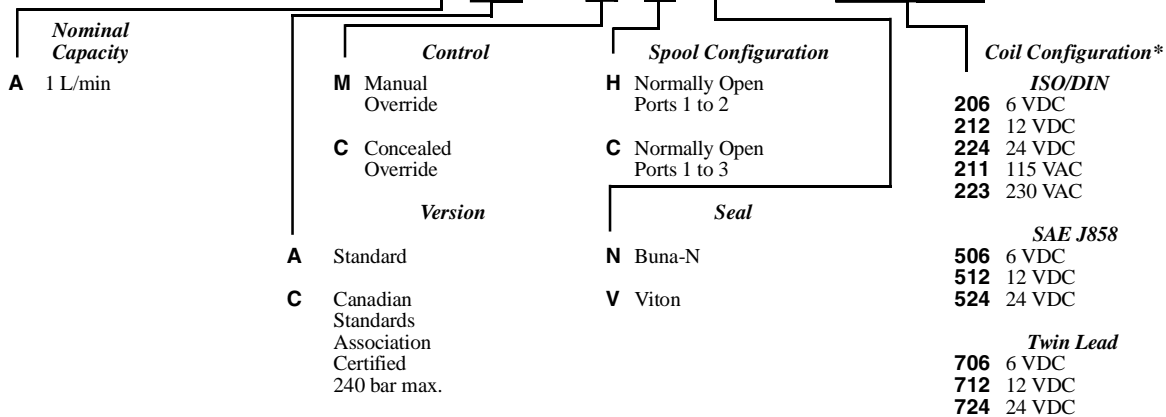

* See page 167 for Solenoid Connector Options

Maximum Leakage (drops/min. at 350 bar at 32 cSt / 43° C) = 10
 Diameter Effective Orifice (mm) = 1,1
 Operating Voltage Tolerance = ± 10%

Power (Watts) = 12
 Typical response Time (ms) = 30

Visit www.sunhydraulics.com for detailed and complete technical information on our full line of products.

HYDRAULICALLY OPERATED, 2-POSITION 3-WAY, SPOOL DIRECTIONAL VALVE - PILOT CAPACITY

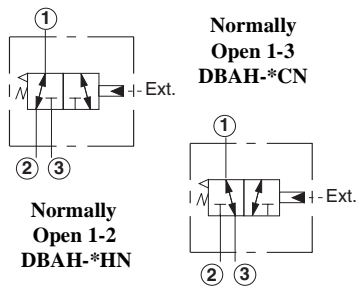
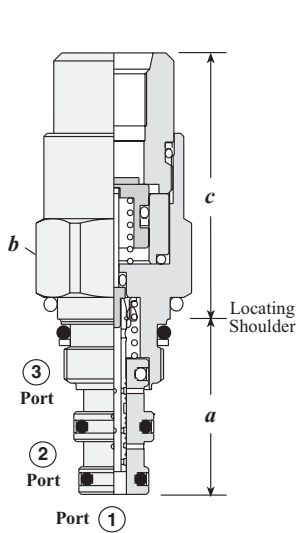

Capacity	Typical Cartridge Model Code	Cavity	Cartridge Dimensions			Installation Torque (Nm)
			<i>a</i>	<i>b</i>	<i>c</i>	
1 L/min.	DBAH – BCN	T - 9A	27,7	22,2	43	35/40

Performance Curves

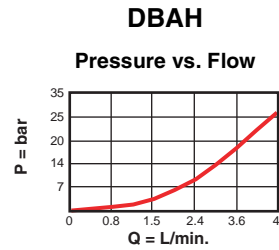

- Maximum operating pressure = 350 bar
- Maximum leakage at 32 cSt = 0,6 cc/min. at 350 bar
- Minimum pilot pressure to operate = 14 bar
- All ports will accept 350 bar including the pilot control port.

DBAH – ★ ★ ★

Nominal Capacity	Pilot Port	Spool Configuration	Seal
A 1 L/min.	A 1/8-27 NPTF	H Normally Open Ports 1 to 2	N Buna-N
	B SAE-4		V Viton
	D 1/8-28 BSPP	C Normally Open Ports 1 to 3	

Visit www.sunhydraulics.com for detailed and complete technical information on our full line of products.

AIR-OPERATED, 2-POSITION 3-WAY, SPOOL DIRECTIONAL VALVE - PILOT CAPACITY

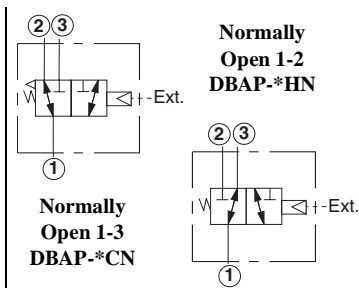
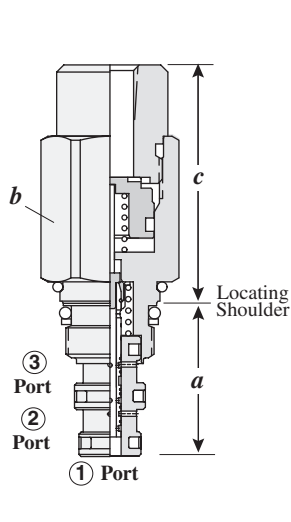

Capacity	Typical Cartridge Model Code	Cavity	Cartridge Dimensions			Installation Torque (Nm)
			a	b	c	
1 L/min.	DBAP - FCN	T - 9A	27,7	22,2	42,2	35/40

Performance Curves

DBAP

Pressure vs. Flow

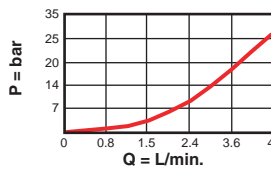

- Maximum operating pressure = 350 bar
- Maximum leakage at 32 cSt = 0,6 cc/min. at 350 bar
- Maximum pilot pressure = 5 bar
- Minimum pilot pressure to operate = 1,5 bar + port 1 pressure/7 bar
- All ports will accept 350 bar with the exception of the pilot port which accepts 35 bar maximum.

DBAP - ***

Nominal Capacity	Pilot Port	Spool Configuration	Seal
A 1 L/min.	E SAE-4	H Normally Open Ports 1 to 2	N Buna-N
	F 1/8-27 NPTF	C Normally Open Ports 1 to 3	V Viton
	P 1/8-28 BSPP		

Visit www.sunhydraulics.com for detailed and complete technical information on our full line of products.

MANUALLY OPERATED, 2-POSITION 3-WAY, SPOOL DIRECTIONAL VALVE - PILOT CAPACITY

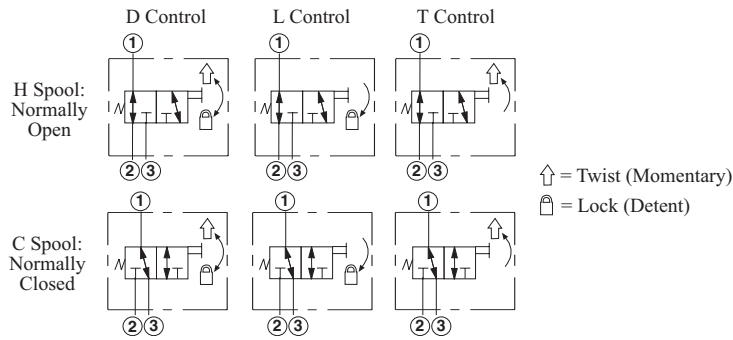
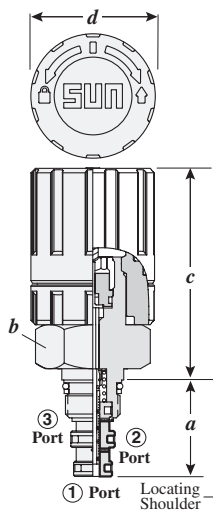

Capacity	Typical Cartridge Model Code	Cavity	Cartridge Dimensions				Installation Torque (Nm)
			a	b	c	d	
1 L/min.	DBAM - TCN	T - 9A	27,7	28,6	61	35,6	35/40

Performance Curves

DBAM

Pressure vs. Flow

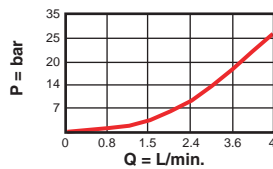

- Maximum operating pressure = 350 bar
- Maximum leakage at 32 cSt = 0,6 cc/min. at 350 bar
- All ports will accept 350 bar.

D B A M - ***

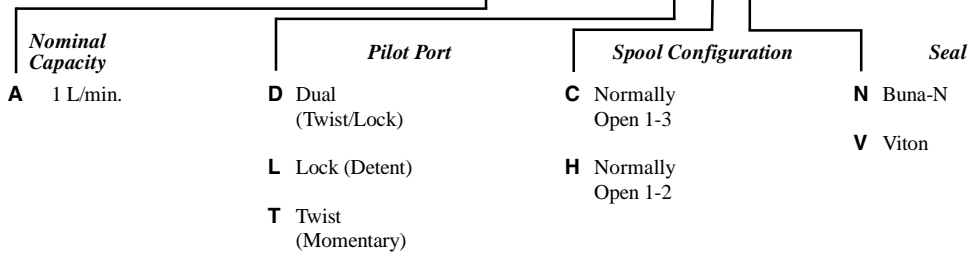

NOTE: Designed for 10,000 cycles of operation maximum under normal conditions.

Visit www.sunhydraulics.com for detailed and complete technical information on our full line of products.

DIRECT ACTING, ADJUSTABLE PILOT RELIEF

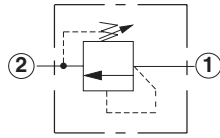
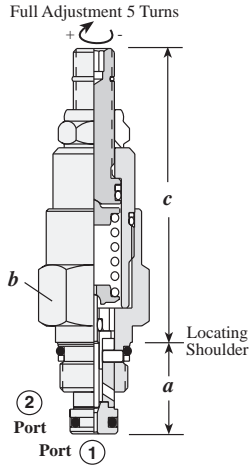

Capacity	Typical Cartridge Model Code	Cavity	Cartridge Dimensions					Installation Torque (Nm)
			a	b	c			
					L	C	K	
10 L/min.	RBAE – LAN	T - 8A	19,1	22,2	61	63	68	35/40

Performance Curves

RBAE

Pressure vs. Flow

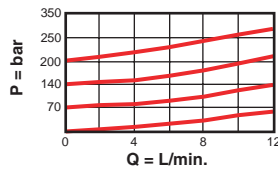

- Maximum operating pressure = 350 bar
- Maximum leakage = 0,3 cc/min. at reseal (reseal = 85% of cracking pressure).
- Ports 1 and 2 may be pressured to 350 bar.
- Back pressure at port 2 (outlet) is directly additive to the pressure setting at port 1 (inlet).
- The main stage valve should first be installed to the correct torque value followed by the T-8A pilot control section into the main stage valve to its required torque value.

R B A E - ★★

Nominal Capacity	Control**	Adjustment Range	Seal
A 10 L/min.	L Standard Screw	A 2 - 210 bar	N Buna-N
		B 2 - 105 bar	V Viton
	C Concealed	C 2 - 420 bar	
	K Handknob	D 2 - 55 bar	
		E 2 - 25 bar	
		W 2 - 315 bar	

** See page 162 for information on Control Options

Adjustment Range Options:
 A, B, C, and W are standard set at 70 bar.
 D Option is standard set at 25 bar.
 E Option is standard set at 14 bar.
 Customer may specify pressure setting.

Visit www.sunhydraulics.com for detailed and complete technical information on our full line of products.

AIR-CONTROLLED, DIRECTING ACTING PILOT RELIEF

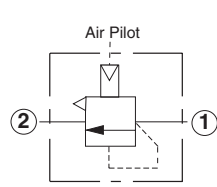
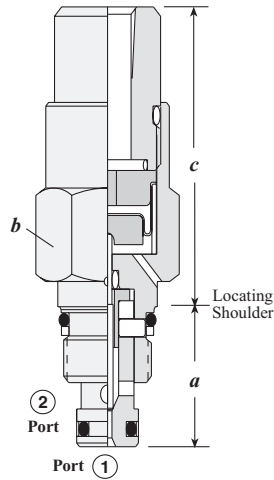

Capacity	Typical Cartridge Model Code	Cavity	Cartridge Dimensions			Installation Torque (Nm)
			a	b	c	
10 L/min.	RBAR – AWN	T - 8A	19,1	22,2	41	35/40
10 L/min.	RBAR – AYN	T - 8A	19,1	28,6	41	35/40

Performance Curves

RBAR

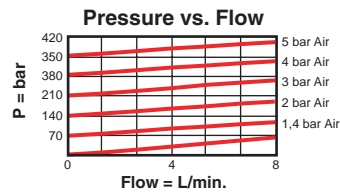
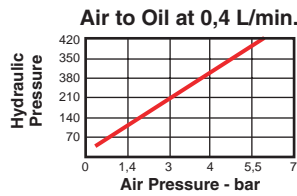

- Maximum operating pressure = 350 bar
- Maximum leakage = 0,3 cc/min. at 350 bar
- Maximum pilot pressure = 10,5 bar
- Ports 1 and 2 may be pressured to 350 bar.
- Back pressure at port 2 has no effect on the valve setting.
- The main stage valve should first be installed to the correct torque value followed by the T-8A pilot control section into the main stage valve to its required torque value.

R B A R – ***

Nominal Capacity	Port	Air Pilot Ratio	Seal
A 10 L/min.	A 1/8-27 NPTF Pilot Port	W 50:1	N Buna-N
	B SAE-4 Pilot Port	Y 75:1	V Viton
	D 1/8-28 BSPP Port		

Visit www.sunhydraulics.com for detailed and complete technical information on our full line of products.

FULLY ADJUSTABLE NEEDLE VALVE - PILOT CAPACITY

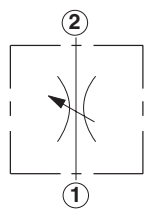
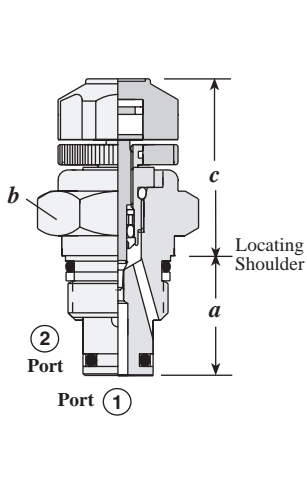

Maximum Orifice	Typical Cartridge Model Code	Cavity	Cartridge Dimensions			Installation Torque (Nm)
			a	b	c	
0,9 mm	NFAB - KXN	T - 8A	19,1	22,2	27,9	35/40

- Maximum operating pressure = 350 bar
- Maximum leakage at shutoff = 0,4 cc/min. at 350 bar
- Effective orifice size = 0,9 mm
- Number of counterclockwise turns fully closed to fully open = 3
- Ports 1 and 2 may be pressured to 350 bar.

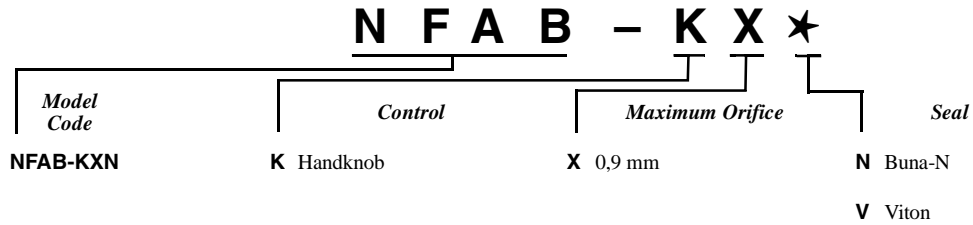

Visit www.sunhydraulics.com for detailed and complete technical information on our full line of products.

ELECTRO-PROPORTIONAL PILOT RELIEF

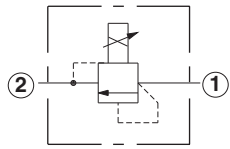
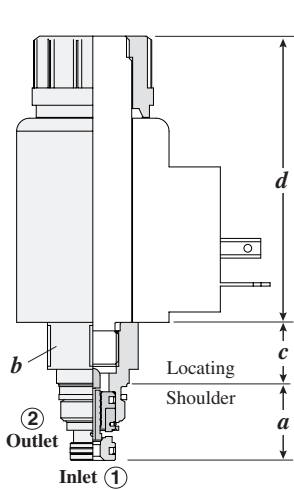

Capacity	Typical Cartridge Model Code	Cavity	Cartridge Dimensions				Installation Torque (Nm)
			a	b	c	d	
1 L/min.	RBAP – MAN	T - 8A	18,8	22,2	15,0	70,1	35/40

Performance Curves

RBAP

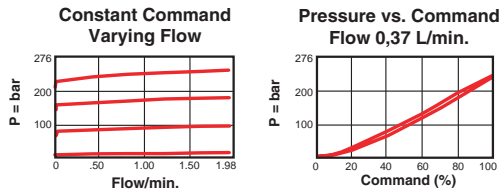

- Maximum operating pressure = 350 bar
- Maximum leakage = 24,6 cc/min at reseal
- Back pressure on the tank port (port 2) is directly additive at a 1:1 ratio to the valve setting
- Reseat exceeds 85% of crack
- Hysteresis with dither <4%
- Hysteresis with DC input <8%
- Linearity with dither <2%
- For optimum performance, an amplifier with current sensing and adjustable dither should be used. Dither should be adjustable between 100 - 250 Hz.

RBAP – ★★

Nominal Capacity	Control	Adjustment Range	Seal
A 1 L/min.	M Manual Override (Standard)	A 20 - 210 bar	N Buna-N
		B 10 - 105 bar	V Viton
		W 35 - 350 bar	

NOTE: Coil must be ordered separately. Use 12V DC or 24V DC (Series 770-*) coils only. See page 167.**

Visit www.sunhydraulics.com for detailed and complete technical information on our full line of products.

Shuttle Valves

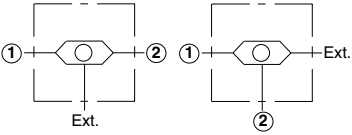
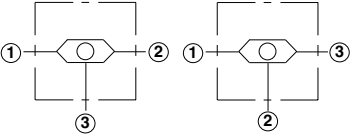
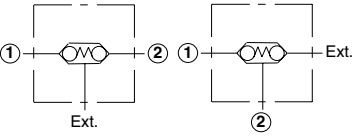
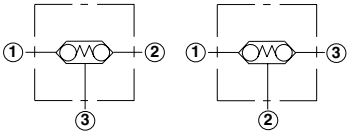
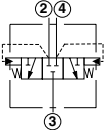
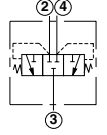
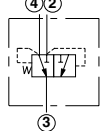
<i>Cartridge Type</i>	<i>Page</i>
 <p>① ——— ② ① ——— Ext. ②</p> <p style="text-align: center;">Ext. ②</p>	<p>Single Ball Shuttle 136</p>
 <p>① ——— ② ① ——— ③ ②</p> <p style="text-align: center;">③ ②</p>	<p>Single Ball Shuttle Valve with Signal at Port 3 or Port 2 137</p>
 <p>① ——— ② ① ——— Ext. ②</p> <p style="text-align: center;">Ext. ②</p>	<p>Back-to-back Check/Shuttle 138</p>
 <p>① ——— ② ① ——— ③ ②</p> <p style="text-align: center;">③ ②</p>	<p>Back-to-back Check/Shuttle 139</p>
 <p style="text-align: center;">② ④</p> <p style="text-align: center;">③</p>	<p>Low Side, 3-position, Hot Oil Shuttle Valve 140</p>
 <p style="text-align: center;">② ④</p> <p style="text-align: center;">③</p>	<p>High Side, 3-position, Shuttle Valve 141</p>
 <p style="text-align: center;">④ ②</p> <p style="text-align: center;">③</p>	<p>Spring Offset, 2-position, High Side Shuttle 142</p>

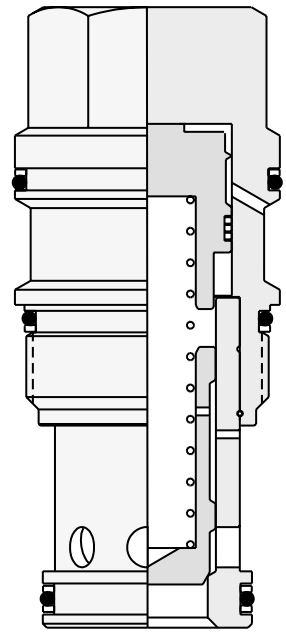

SINGLE BALL SHUTTLE

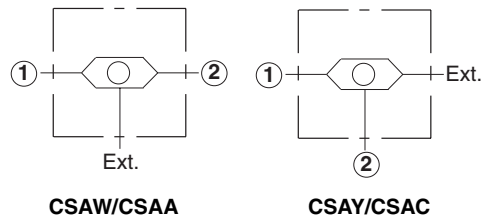
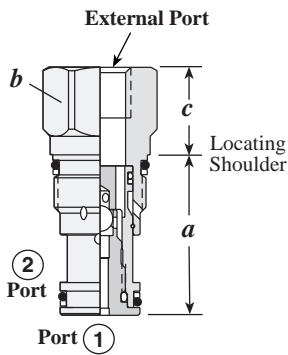

Nominal Capacity	Typical Cartridge Model Code	Cavity	Cartridge Dimensions			Installation Torque (Nm)
			a	b	c	
5 L/min.	CSAW – BXN	T - 162A	31	19,1	20,8	35/40
5 L/min.	CSAY – BXN	T - 162A	31	19,1	20,6	35/40
10 L/min.	CSAA – BXN	T - 13A	35,1	22,2	30,2	40/50
10 L/min.	CSAC – BXN	T - 13A	35,1	22,2	30,2	40/50

Performance Curves

CSAW/CSAY

CSAA/CSAC

Typical Pressure Drop

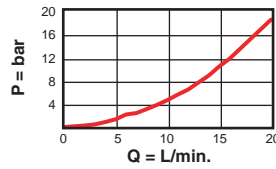
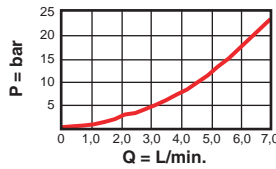

- Maximum operating pressure = 350 bar
- Maximum valve leakage = 0,4 cc/min.

CS A * - * X *

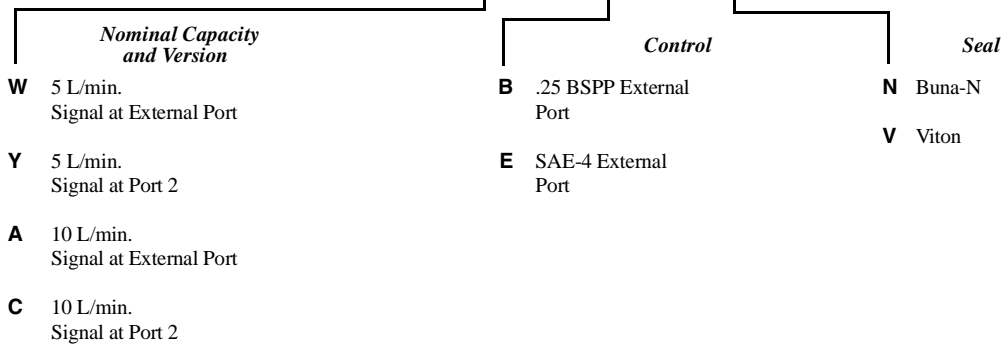

Visit www.sunhydraulics.com for detailed and complete technical information on our full line of products.

SINGLE BALL SHUTTLE VALVE WITH SIGNAL AT PORT 3 OR PORT 2

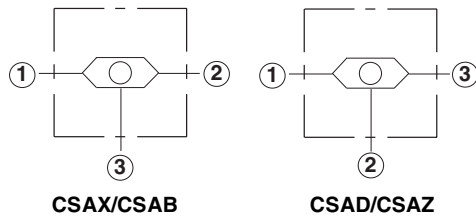
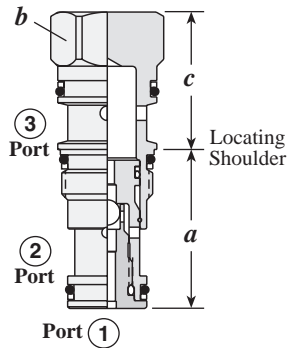

Nominal Capacity	Typical Cartridge Model Code	Cavity	Cartridge Dimensions			Installation Torque (Nm)
			a	b	c	
5 L/min.	CSAX – XXN	T - 163A	31	19,1	32	35/40
5 L/min.	CSAZ – XXN	T - 163A	31	19,1	31,8	35/40
10 L/min.	CSAB – XXN	T - 11A	34,9	22,2	31	40/50
10 L/min.	CSAD – XXN	T - 11A	35,1	22,2	30,2	40/50

Performance Curves

CSAX/CSAZ

CSAB/CSAD

Typical Pressure Drop

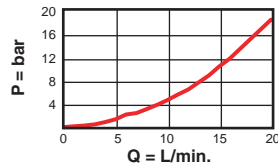
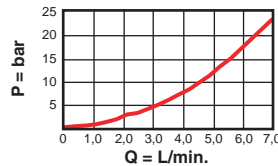

- Maximum operating pressure = 350 bar
- Maximum valve leakage = 0,4 cc/min.

CS A ★ - X X ★

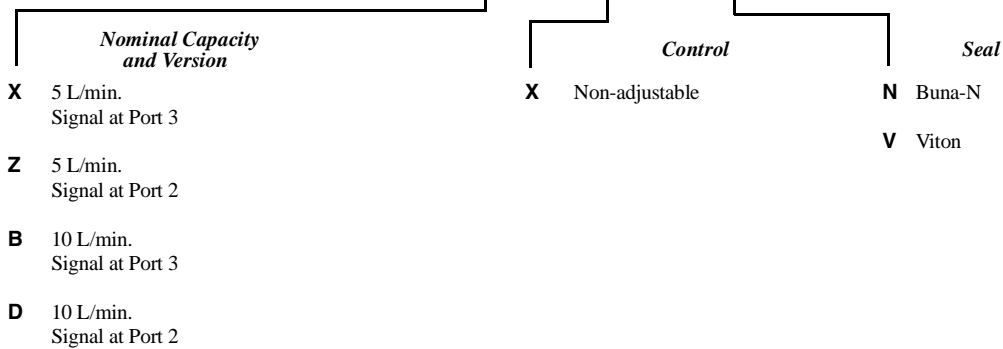

Visit www.sunhydraulics.com for detailed and complete technical information on our full line of products.

BACK-TO-BACK CHECK/SHUTTLE

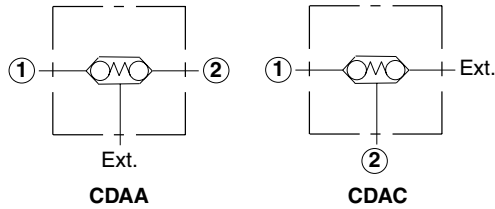
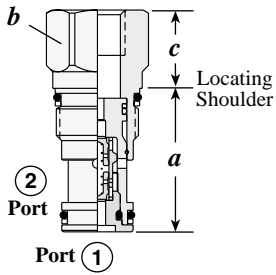

Nominal Capacity	Typical Cartridge Model Code	Cavity	Cartridge Dimensions			Installation Torque (Nm)
			a	b	c	
10 L/min.	CDAA – BBN	T - 13A	35,1	22,2	30,2	40/50
10 L/min.	CDAC – BBN	T - 13A	35,1	22,2	19	40/50

Performance Curves

CDAA/CDAC

Typical Pressure Drop

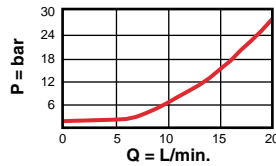

- Maximum operating pressure = 350 bar
- Maximum valve leakage = 0,4 cc/min.
- The back-to-back checks do not provide a means of lowering a signal. They will trap a high signal if the load pressures drop to a lower pressure. Some means of bleeding off the signal should be provided.
- 1,0 bar check.

CD A ★ - ★ B ★

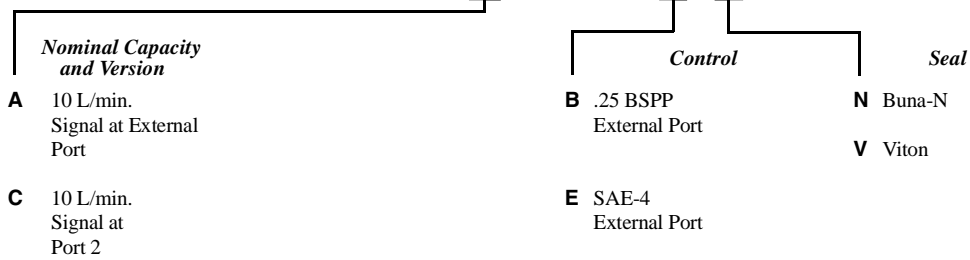

Visit www.sunhydraulics.com for detailed and complete technical information on our full line of products.

BACK-TO-BACK CHECK/SHUTTLE

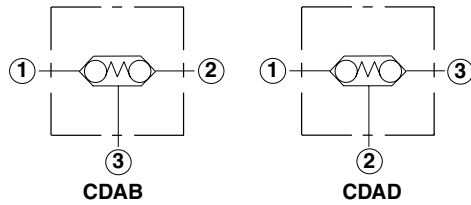
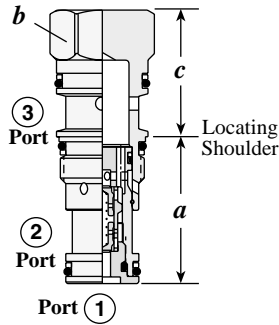

Nominal Capacity	Typical Cartridge Model Code	Cavity	Cartridge Dimensions			Installation Torque (Nm)
			a	b	c	
10 L/min.	CDAB – XBN	T - 11A	35,1	22,2	30,2	40/50
10 L/min.	CDAD – XBN	T - 11A	35,1	22,2	30,2	40/50

Performance Curves

CDAB/CDAD

Typical Pressure Drop

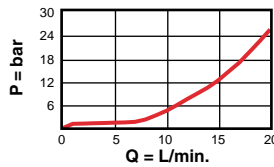

- Maximum operating pressure = 350 bar
- Maximum valve leakage = 0,4 cc/min.
- The back-to-back checks do not provide a means of lowering a signal. They will trap a high signal if the load pressures drop to a lower pressure. Some means of bleeding off the signal should be provided.
- 1,0 bar check

CD A ★ – X B ★

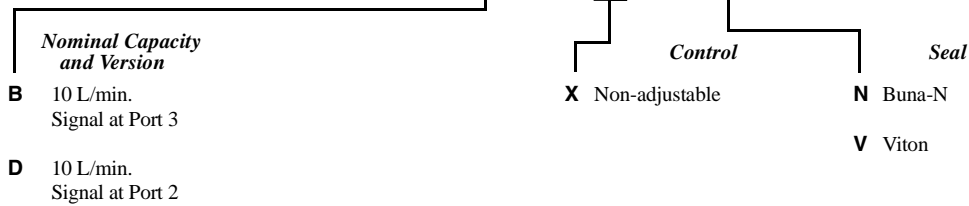

Visit www.sunhydraulics.com for detailed and complete technical information on our full line of products.

LOW SIDE, 3-POSITION, HOT OIL SHUTTLE VALVE

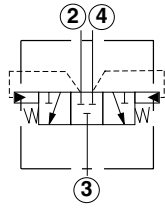
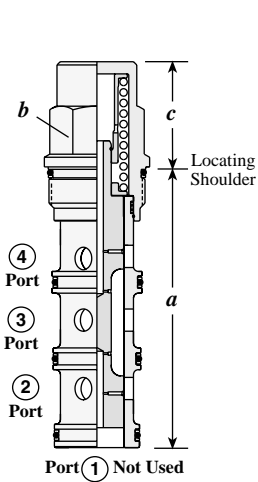

Nominal Capacity	Typical Cartridge Model Code	Cavity	Cartridge Dimensions			Installation Torque (Nm)
			a	b	c	
60 L/min.	DSCH – XHN	T - 31A	84,8	22,2	30	40/50
120 L/min.	DSEH – XHN	T - 32A	92,2	28,6	34	60/70
240 L/min.	DSGH – XHN	T - 33A	114,4	31,8	42	200/215
480 L/min.	DSIH – XHN	T - 34A	139,7	41,3	51	465/500

Performance Curves

DSCH

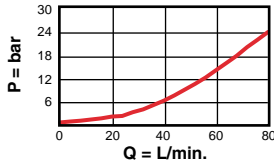

DSEH

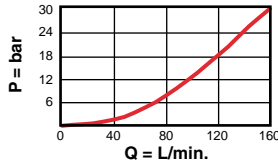

DSGH

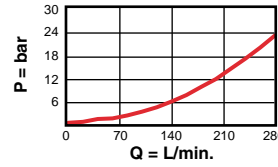

DSIH

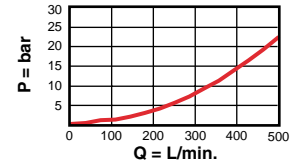

Typical Pressure Drop

- Maximum operating pressure = 350 bar
- Pilot flow = DSCH, DSEH: 0,38 L/min., DSGH, DSIH: 0,75 L/min. (Port 2 and 4 to Port 3).
- Note: Low shift values can potentially result in charge pump pressure alone inadvertently shifting the valve. Use care when selecting shift pressure.
- Pressures on Ports 2 and 4 must equalize before reversed shift can take place.

DS ★ H – X ★ ★

Nominal Capacity	Control	Shifting Pressure	Seal
C 60 L/min.	X Non-adjustable	G 10,0 bar	N Buna-N
E 120 L/min.		H 14,0 bar	V Viton
G 240 L/min.			
I 480 L/min.			

Visit www.sunhydraulics.com for detailed and complete technical information on our full line of products.

HIGH SIDE, 3-POSITION, SHUTTLE VALVE

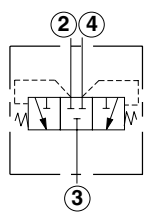
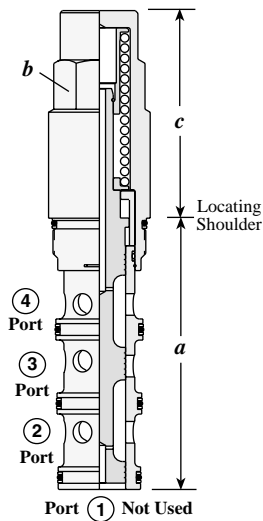

Nominal Capacity	Typical Cartridge Model Code	Cavity	Cartridge Dimensions			Installation Torque (Nm)
			a	b	c	
60 L/min.	DSCS – XCN	T - 31A	84,8	22,2	37	40/50
120 L/min.	DSES – XCN	T - 32A	92,2	28,6	42	60/70
240 L/min.	DSGS – XCN	T - 33A	114,4	31,8	72	200/215
480 L/min.	DSIS – XCN	T - 34A	139,7	41,3	107	465/500

Performance Curves

DSCS

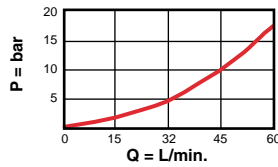

DSES

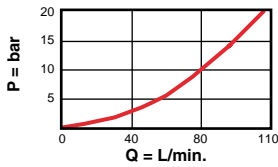

DSGS

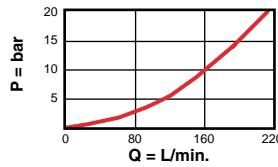

DSIS

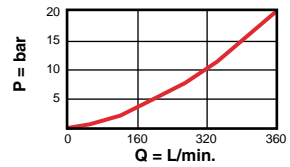

Pressure Drop, Port 2 or 4 to Port 3

- Maximum operating pressure = 350 bar
- Maximum valve leakage = DSCS: 32,8 cc/min. at 70 bar, DSES: 49,2 cc/min. at 70 bar, DSGS: 65,5 cc/min. at 70 bar, DSIS: 81,9 cc/min. at 70 bar

DS * S - X * *

Nominal Capacity	Control	Shifting Pressure	Seal
C 60 L/min.	X Non-adjustable	C 2,0 bar	N Buna-N
E 120 L/min.		E 5,0 bar	V Viton
G 240 L/min.		F 7,0 bar	
I 480 L/min.		G 10,0 bar	

Visit www.sunhydraulics.com for detailed and complete technical information on our full line of products.

SPRING OFFSET, 2-POSITION, HIGH SIDE SHUTTLE

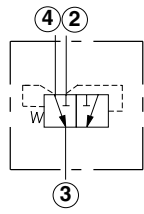
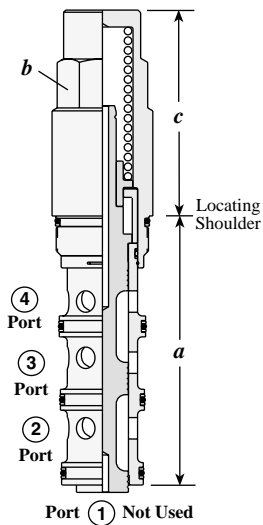

Nominal Capacity	Typical Cartridge Model Code	Cavity	Cartridge Dimensions			Installation Torque (Nm)
			a	b	c	
60 L/min.	DSCO – XCN	T - 31A	84,8	22,2	37	40/50
120 L/min.	DSEO – XCN	T - 32A	92,2	28,6	42	60/70
240 L/min.	DSGO – XCN	T - 33A	114,4	31,8	72	200/215
480 L/min.	DSIO – XCN	T - 34A	139,7	41,3	107	465/500

Performance Curves

DSCO

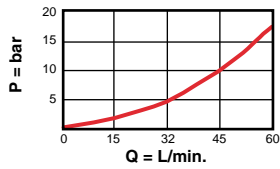

DSEO

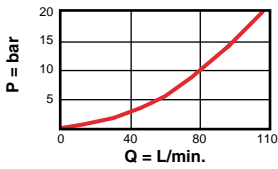

DSGO

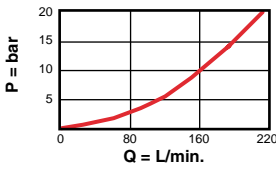

DSIO

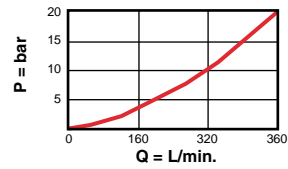

Pressure Drop, Port 4 or 2 to Port 3

- Maximum operating pressure = 350 bar
- Minimum pilot pressure required to shift valve = C Range: 2 bar, E Range: 5 bar

DS * O - X * *

Nominal Capacity	Control	Shifting Pressure	Seal
C 60 L/min.	X Non-adjustable	C 2,0 bar	N Buna-N
E 120 L/min.		E 5,0 bar	V Viton
G 240 L/min.			
I 480 L/min.			

Visit www.sunhydraulics.com for detailed and complete technical information on our full line of products.

Circuit Savers

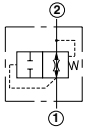
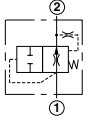
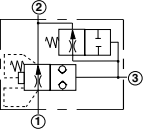
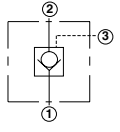
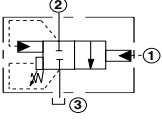
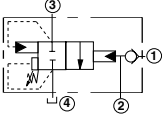
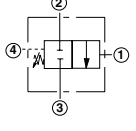
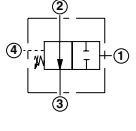
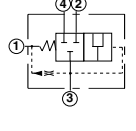
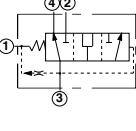
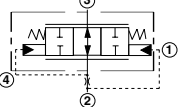
Cartridge Type	Page
	144
	145
	146
	147
	148
	149
	150
	151
	152
	153
	154

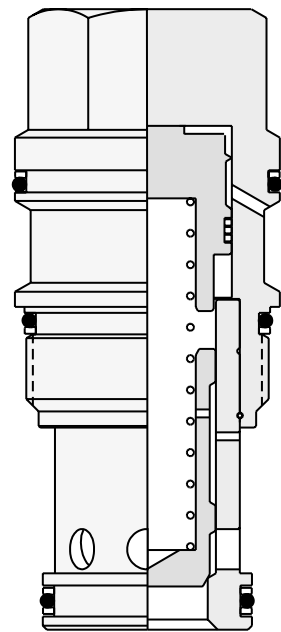

FIXED ORIFICE, FLOW FUSE VALVE

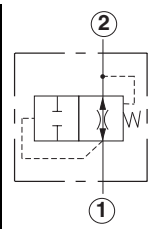
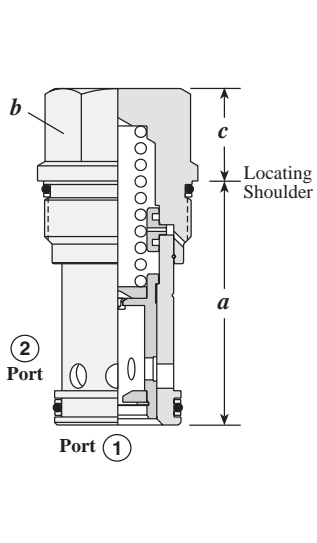

Capacity	Typical Cartridge Model Code	Cavity	Cartridge Dimensions			Installation Torque (Nm)
			<i>a</i>	<i>b</i>	<i>c</i>	
2 - 23 L/min.	FQCA - XAN	T - 13A	34,9	22,2	19	40/50
4 - 60 L/min.	FQEA - XAN	T - 5A	41,1	28,6	18	60/70
4 - 95 L/min.	FQGA - XAN	T - 16A	61,9	31,8	25	200/215
4 - 200 L/min.	FQIA - XAN	T - 18A	79,4	41,3	31	465/500

Performance Curves

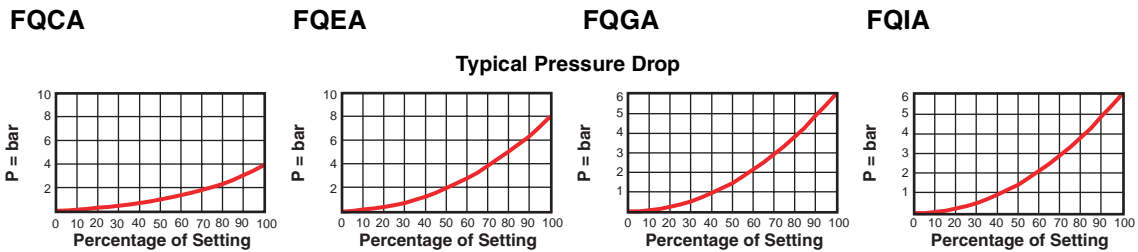

- Maximum operating pressure = 350 bar
- Maximum valve leakage = FQCA: 32,8 cc/min. at 70 bar, FQEA: 49,2 cc/min. at 70 bar, FQGA: 65,5 cc/min. at 70 bar, FQIA: 81,9 cc/min. at 70 bar.
- Valve closes when flow from port 1 to port 2 exceeds the setting of the valve. Valve resets when pressures at port 1 and port 2 are equal.
- Flow setting should be at least 25% above maximum normal system flow.

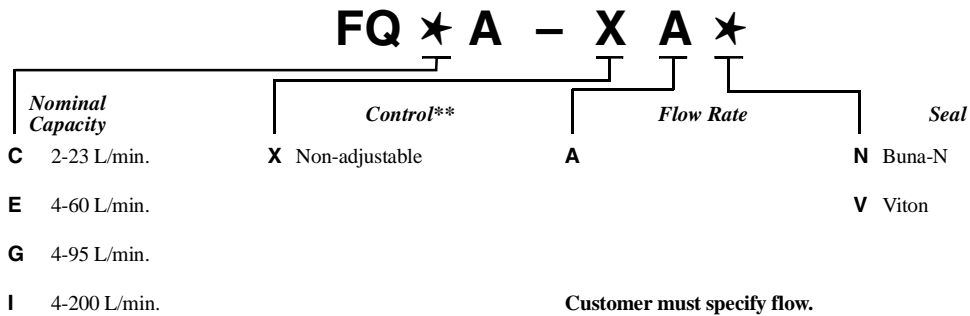

Visit www.sunhydraulics.com for detailed and complete technical information on our full line of products.

AIR BLEED AND START-UP VALVE

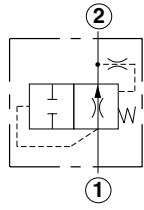
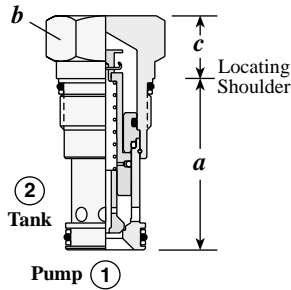

Capacity	Typical Cartridge Model Code	Cavity	Cartridge Dimensions			Installation Torque (Nm)
			a	b	c	
15 - 200 L/min.	NQEB - XAN	T - 3A	47,8	28,6	18	60/70

Performance Curves

NQEB

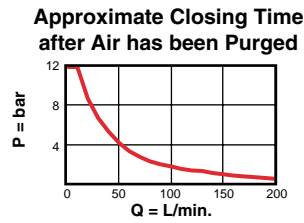
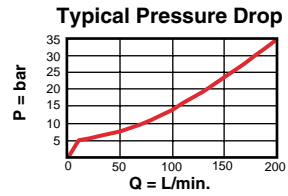

- Maximum operating pressure = 350 bar
- Air-bleed and start-up valves require a minimum of 15 L/min. flow rate and 5,5 bar system pressure.
- The valve will re-open when system pressure falls below 1,7 bar.
- After air has been purged, closing times vary from approximately 12 seconds at 15 L/min. to 0.5 seconds at 200 L/min.

NQEB - XA★

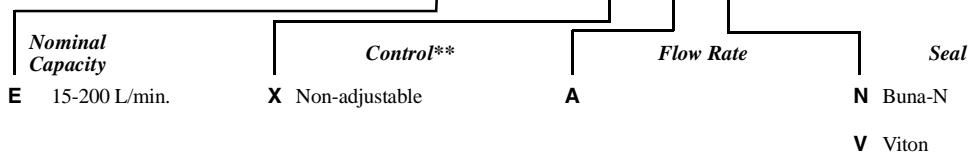

Visit www.sunhydraulics.com for detailed and complete technical information on our full line of products.

CHECK, PILOT-TO-CLOSE

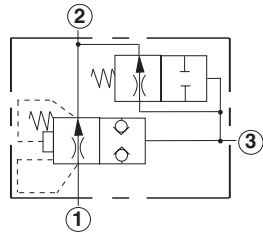
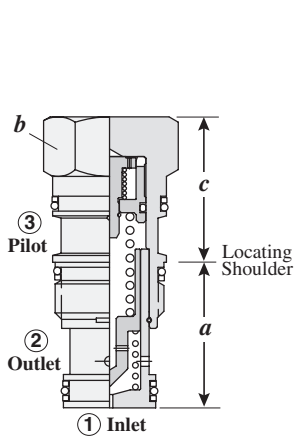

Orifice Diameter	Typical Cartridge Model Code	Cavity	Cartridge Dimensions			Installation Torque (Nm)
			a	b	c	
1,27 mm	COFO - XDN	T - 2A	35,1	28,6	35,1	60/70

Performance Curves

COFO

Pressure vs. Flow

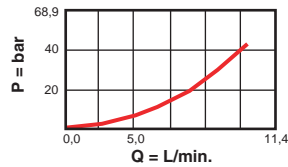

- Maximum operating pressure = 350 bar
- Pilot ratio = 120:1
- Leakage rate when closed = 0,3 cc/min.

COFO - XDN

Orifice Diameter	Control**	Minimum Pressure	Seal
F 1,27 mm	X Standard Pilot	D 3,5 bar	N Buna-N V Viton

** See page 162 for information on Control Options.

Visit www.sunhydraulics.com for detailed and complete technical information on our full line of products.

CHECK, PILOT-TO-CLOSE

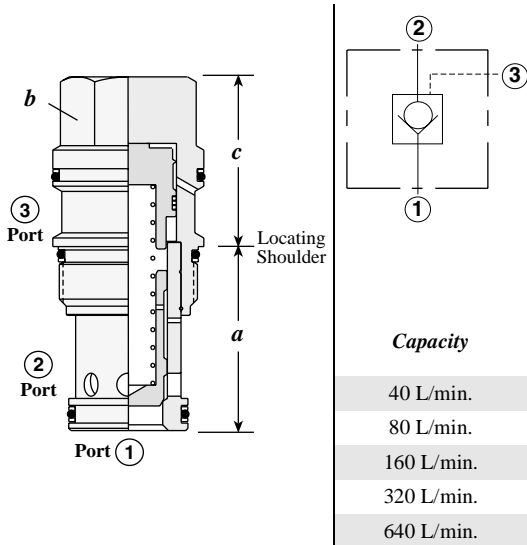

Capacity	Typical Cartridge Model Code	Cavity	Cartridge Dimensions			Installation Torque (Nm)
			a	b	c	
40 L/min.	COBA – XCN	T - 163A	31	19,1	32	35/40
80 L/min.	CODA – XCN	T - 11A	34,9	22,2	31	40/50
160 L/min.	COFA – XCN	T - 2A	34,9	28,6	35	60/70
320 L/min.	COHA – XCN	T - 17A	46	31,8	46	200/245
640 L/min.	COJA – XCN	T - 19A	63,5	41,3	59	465/500

Performance Curves

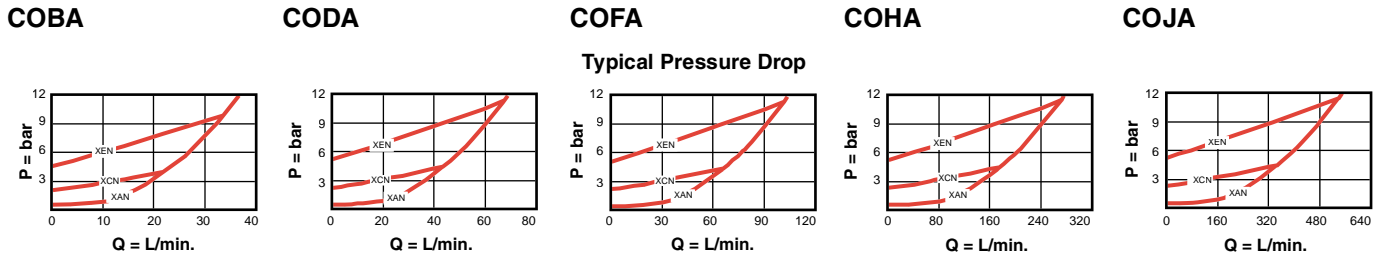

- Maximum operating pressure = 350 bar
- Pilot ratio = 1.8:1
- Leakage rate when closed = 0,07 cc/min.

CO * A - * * *

Nominal Capacity	Control**	Cracking Pressure	Seal
B 40 L/min.	X Standard Pilot	A *0,3 bar	N Buna-N
D 80 L/min.		B *1,0 bar	V Viton
F 160 L/min.		C 2,0 bar	
H 320 L/min.		D 3,5 bar	
J 640 L/min.		E 5,0 bar	
		F 7,0 bar	

** See page 162 for information on Control Options

* COBA and COFA are not available in A and B Cracking Pressures.

Visit www.sunhydraulics.com for detailed and complete technical information on our full line of products.



ACCUMULATOR SENSE, PUMP UNLOAD VALVE - PILOT CAPACITY

Full Adjustment 5 Turns

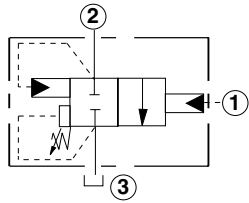
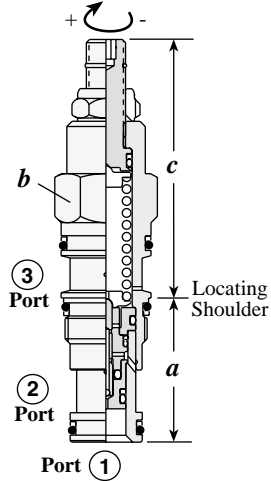

Capacity	Typical Cartridge Model Code	Cavity	Cartridge Dimensions				Installation Torque (Nm)
			a	b	L	C	
0,8 L/min.	QPAA – LAN	T - 11A	34,9	22,2	64	66	40/50

- Maximum operating pressure = 350 bar
- When applying this cartridge, a separate drain line is required to prevent erratic operation caused by tank line pressure fluctuations.
- Note: Careful consideration should be given when selecting an adjustment range. System pressure drops and flows tend to affect the operation of unloading valves.

QP A ★ – ★ ★ ★

Nominal Capacity	Version	Control**	Adjustment Range	Seal
A 0,8 L/min.	A 15% Nominal Differential	L Standard Screw	A 70 - 210 bar	N Buna-N
	B 20% Nominal Differential	C Tamper Resistant	B 28 - 105 bar	V Viton
	C 30% Nominal Differential		C 140 - 350 bar	
	D 50% Nominal Differential		D 14 - 55 bar	

Adjustment Range Options:
 A and B Options are standard set at 70 bar.
 D Option is standard set at 25 bar.
 C Option is standard set at 140 bar.
Customer may specify pressure setting.

** See page 162 for information on Control Options

Visit www.sunhydraulics.com for detailed and complete technical information on our full line of products.

ACCUMULATOR SENSE, PUMP UNLOAD VALVE WITH CHECK - PILOT CAPACITY

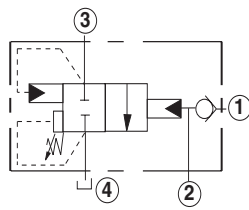
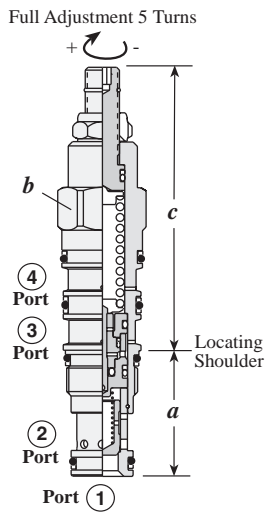

Capacity	Typical Cartridge Model Code	Cavity	Cartridge Dimensions				Installation Torque (Nm)
			a	b	L	C	
0,8 L/min.	QCDA - LAN	T - 21A	34,9	22,2	79	81	40/50

- Maximum operating pressure = 350 bar
- Check valve = 50 L/min.
- Free flow check cracking pressure = 0,3 bar
- Pressure drop, port 1 to port 2 = 5 bar at 50 L/min.
- When applying this cartridge, a separate drain line is required to prevent erratic operation caused by tank line pressure fluctuations.
- Note: Careful consideration should be given when selecting an adjustment range. System pressure drops and flows tend to affect the operation of unloading valves.

Nominal Capacity	Version	Control**	Adjustment Range	Seal
D 0,8 L/min.	A 15% Nominal Differential	L Standard Screw	A 70 - 210 bar	N Buna-N
	B 20% Nominal Differential	C Tamper Resistant	B 28 - 105 bar	V Viton
	C 30% Nominal Differential		C 140 - 350 bar	
	D 50% Nominal Differential		D 14 - 55 bar	

Adjustment Range Options:
 A and B Options are standard set at 70 bar.
 D Option is standard set at 25 bar.
 C Option is standard set at 140 bar.
Customer may specify pressure setting.

** See page 162 for information on Control Options

Visit www.sunhydraulics.com for detailed and complete technical information on our full line of products.

DIRECT ACTING, 2-WAY DIRECTIONAL VALVE WITH DRAIN TO PORT 4 - NORMALLY CLOSED

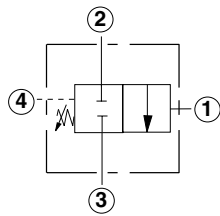
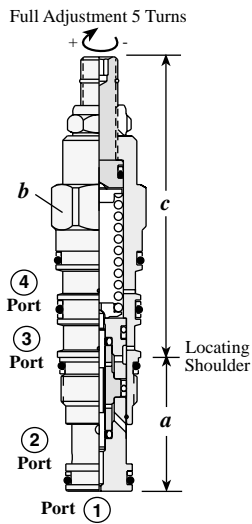

Capacity	Typical Cartridge Model Code	Cavity	Cartridge Dimensions			Installation Torque (Nm)
			a	b	c	
2 L/min.	DRAX - LAN	T - 21A	34,9	22,2	79	40/50

Performance Curves

DRAX

Pressure Drop vs. Flow
Port 2 to Port 3

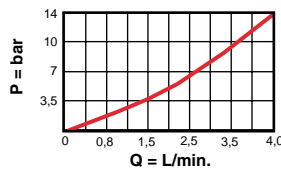

- Maximum operating pressure = 350 bar
- The pilot area (port 1) and the spring chamber drain (port 4) are positively sealed.
- There is spool leakage between the work ports (ports 2 and 3), 0,8 cc/min. at 70 bar.

DRAX - L * N

Nominal Capacity	Control**	Adjustment Range	Seal
A 2 L/min.	L Standard Screw	A 70 - 210 bar	N Buna-N
		C 140 - 420 bar	V Viton

** See page 162 for information on Control Options

Adjustment Range Options:
A Option is standard set at 70 bar.
C Option is standard set at 140 bar.
Customer may specify pressure setting.

Visit www.sunhydraulics.com for detailed and complete technical information on our full line of products.

DIRECT ACTING, 2-WAY DIRECTIONAL VALVE WITH DRAIN TO PORT 4 - NORMALLY OPEN

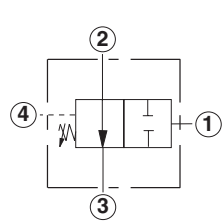
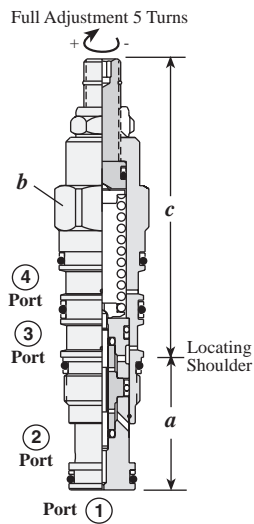

Capacity	Typical Cartridge Model Code	Cavity	Cartridge Dimensions			Installation Torque (Nm)
			a	b	c	
2 L/min.	DRAY - LAN	T - 21A	34,9	22,2	81	40/50

Performance Curves

DRAY

Pressure Drop vs. Flow
Port 2 to Port 3

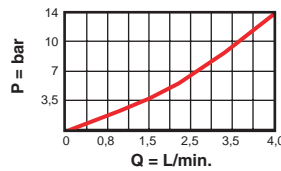

- Maximum operating pressure = 350 bar
- The pilot area (port 1) and the spring chamber drain (port 4) are positively sealed.
- There is spool leakage between the work ports (ports 2 and 3), 0,8 cc/min. at 70 bar.

DRAY - L * N

Nominal Capacity	Control**	Adjustment Range	Seal
A 2 L/min.	L Standard Screw	A 70 - 210 bar	N Buna-N
		C 140 - 420 bar	V Viton

** See page 162 for information on Control Options

Adjustment Range Options:
A Option is standard set at 70 bar.
C Option is standard set at 140 bar.
Customer may specify pressure setting.

Visit www.sunhydraulics.com for detailed and complete technical information on our full line of products.

VENT-TO-SHIFT 2-POSITION DIVERTER VALVE - NORMALLY CLOSED

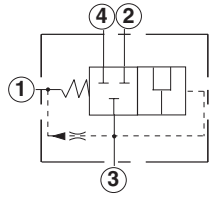
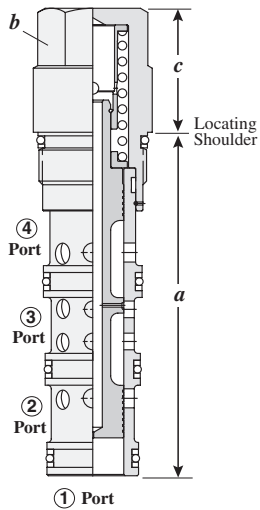

Capacity	Typical Cartridge Model Code	Cavity	Cartridge Dimensions			Installation Torque (Nm)
			a	b	c	
60 L/min.	DSCX – XEN	T - 31A	84,8	22,2	30,2	40/50
120 L/min.	DSEX – XEN	T - 32A	92,2	28,6	33,3	60/70
240 L/min.	DSGX – XEN	T - 33A	114,6	31,8	41,4	200/215
480 L/min.	DSIX – XEN	T - 34A	139,7	41,3	53,8	465/500

Performance Curves

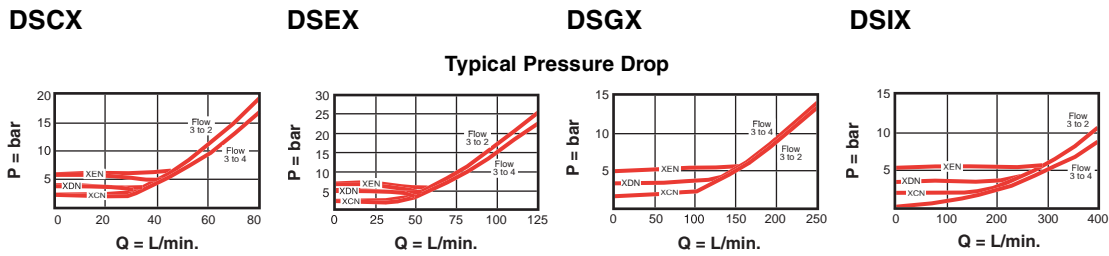

- Maximum operating pressure = 350 bar
- Nominal vent flow = DSCX, DSEX: 0,38 L/min., DSGX, DSIX: 0,60 L/min.
- There must be a pressure source at port 3, relative to port 1, to shift the valve.

DS ★ X – X E ★

Nominal Capacity	Control	Minimum Control Pressure	Seal
C 60 L/min.	X Non-adjustable	C 2 bar	N Buna-N
E 120 L/min.		D 3,5 bar	V Viton
G 240 L/min.		E 5 bar	
I 480 L/min.			

Customer may specify pressure setting.

Visit www.sunhydraulics.com for detailed and complete technical information on our full line of products.

VENT-TO-SHIFT, 2-POSITION, 3-WAY DIVERTER VALVE

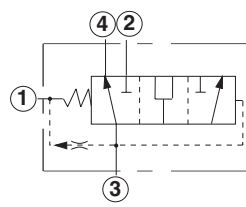
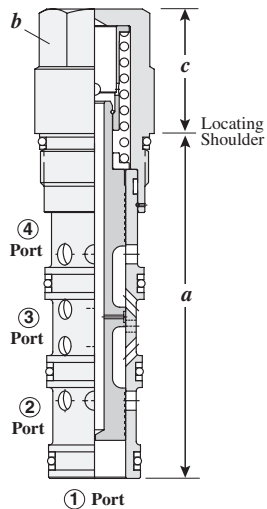

Capacity	Typical Cartridge Model Code	Cavity	Cartridge Dimensions			Installation Torque (Nm)
			a	b	c	
60 L/min.	DSCY – XEN	T - 31A	84,8	22,2	30,2	40/50
120 L/min.	DSEY – XEN	T - 32A	92,2	28,6	33,3	60/70
240 L/min.	DSGY – XEN	T - 33A	114,6	31,8	41,4	200/215
480 L/min.	DSIY – XEN	T - 34A	139,7	41,3	53,8	465/500

Performance Curves

DSCY

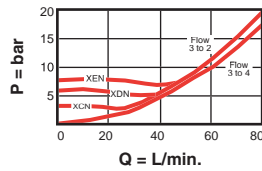

DSEY

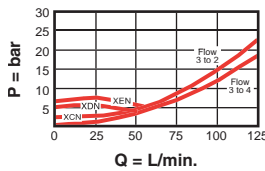

DSGY

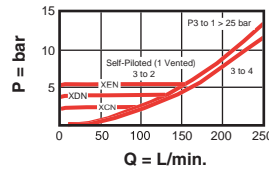

DSIY

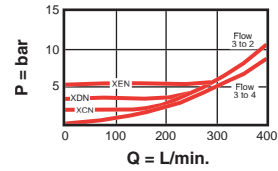

Typical Pressure Drop

- Maximum operating pressure = 350 bar
- Nominal vent flow = DSCY, DSEY: 0,38 L/min., DSGY, DSIY: 0,60 L/min.
- There must be a pressure source at port 3, relative to port 1, to shift the valve.

DS ★ Y – X E ★

Nominal Capacity	Control	Minimum Control Pressure	Seal
C 60 L/min.	X Non-adjustable	C 2 bar	N Buna-N
E 120 L/min.		D 3,5 bar	V Viton
G 240 L/min.		E 5 bar	
I 480 L/min.			

Customer may specify pressure setting.

Visit www.sunhydraulics.com for detailed and complete technical information on our full line of products.

NORMALLY OPEN, BI-DIRECTIONAL, MODULATING LOGIC ELEMENT

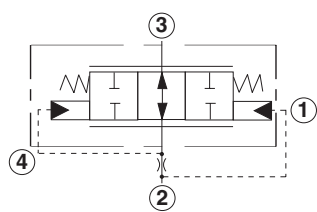
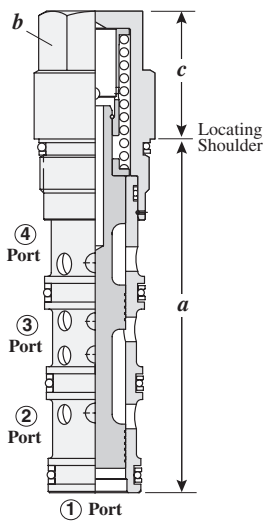

Capacity	Typical Cartridge Model Code	Cavity	Cartridge Dimensions			Installation Torque (Nm)
			a	b	c	
60 L/min.	LHDT - XFN	T - 31A	84,8	22,2	30,2	40/50
120 L/min.	LHFT - XFN	T - 32A	92,2	28,6	33,3	60/70
240 L/min.	LHHT - XFN	T - 33A	114,3	31,8	41,3	200/215

Performance Curves

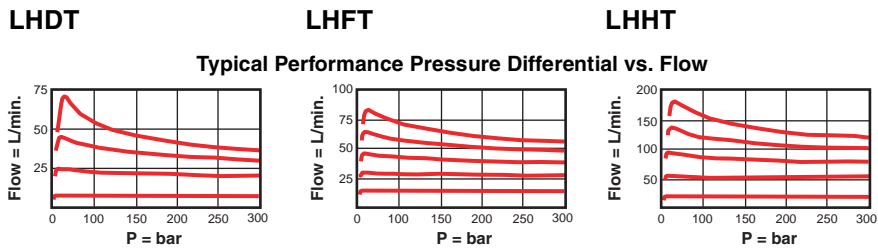

- Maximum operating pressure = 350 bar

LH * T - X F *

Nominal Capacity	Control	Nominal Control Pressure	Seal
D 60 L/min.	X Non-adjustable	D 3,5 bar	N Buna-N
F 120 L/min.		E 5 bar	V Viton
H 240 L/min.		F 7 bar	

Customer may specify pressure setting.

Visit www.sunhydraulics.com for detailed and complete technical information on our full line of products.

Hybrid Relief Valves

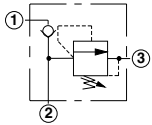
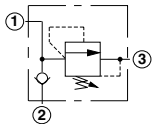
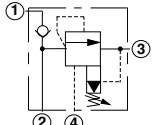
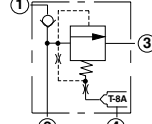
	<i>Cartridge Type</i>	<i>Page</i>
	Direct Acting Relief Valve - Before Check	156
	Direct Acting Relief Valve - After Check	157
	Ventable, Pilot Operated, Balanced Piston, Relief Valve - Before Check	158
	Ventable, Pilot Operated, Balanced Piston, Relief Valve - Before Check with Integral Pilot Control Cavity	159

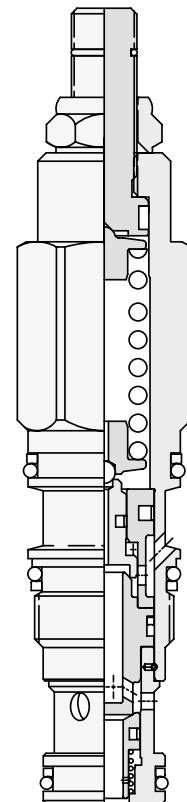

DIRECT ACTING RELIEF VALVE - BEFORE CHECK

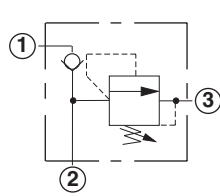
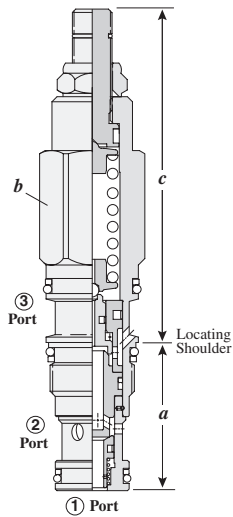

Capacity	Typical Cartridge Model Code	Cavity	Cartridge Dimensions					Installation Torque (Nm)
			a	b	c			
					L	C	K	
40 L/min.	HRDA - LAN	T - 11A	35,0	22,2	78,9	80,2	85,0	45/50

Performance Curves

HRDA

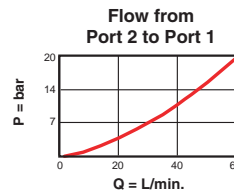
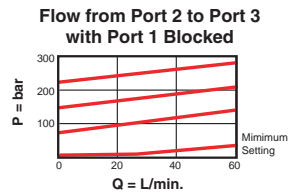

- Maximum operating pressure = 350 bar
- Maximum valve leakage at reseal = 0,3 cc/min.
- Reseat exceeds 85% of crack pressure
- Factory pressure setting established at 15 L/min.
- Free flow check cracking pressure = 1,7 bar
- Typical response = 2 ms
- The check portion of the valve has a maximum leakage rate of less than 0,07 cc/min.
- Note: This valve deviates from Sun's normal flow path for three port relief valves; port 2 is the inlet, port 1 is the system and port 3 is tank. Therefore, it is probably not useable in existing standard Sun relief manifolds.

HRDA - LAN

Nominal Capacity	Control**	Adjustment Range	Seal
D 40 L/min.	L Standard Screw Adjustment	A 35 - 210 bar	N Buna-N
	C Tamper Resistant Factory Set	W 55 - 315 bar	V Viton
	K Handknob		

** See page 162 for information on Control Options

Customer may specify pressure setting.

Visit www.sunhydraulics.com for detailed and complete technical information on our full line of products.

DIRECT ACTING RELIEF VALVE - AFTER CHECK

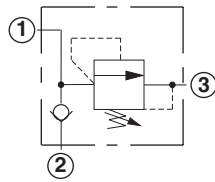
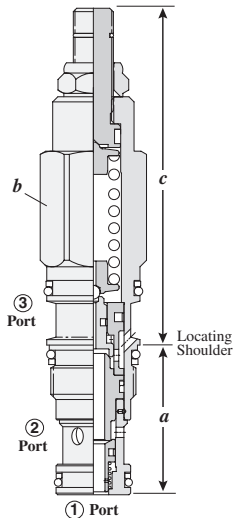

Capacity	Typical Cartridge Model Code	Cavity	Cartridge Dimensions					Installation Torque (Nm)
			a	b	c			
					L	C	K	
40 L/min.	HRDB - LAN	T - 11A	35,0	22,2	78,9	80,2	85,0	45/50

Performance Curves

HRDB

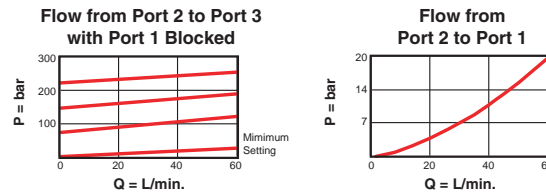

- Maximum operating pressure = 350 bar
- Maximum valve leakage at reseal = 0,3 cc/min.
- Reseat exceeds 85% of crack pressure
- Factory pressure setting established at 15 L/min.
- Free flow check cracking pressure = 1,7 bar
- Typical response = 2 ms
- The check portion of the valve has a maximum leakage rate of less than 0,07 cc/min.
- Note: This valve deviates from Sun's normal flow path for three port relief valves; port 2 is the inlet, port 1 is the system and port 3 is tank. Therefore, it is probably not useable in existing standard Sun relief manifolds.

HRDB - LAN

Nominal Capacity	Control**	Adjustment Range	Seal
D 40 L/min.	L Standard Screw Adjustment	A 35 - 210 bar	N Buna-N
	C Tamper Resistant Factory Set	W 55 - 315 bar	V Viton
	K Handknob		

** See page 162 for information on Control Options

Customer may specify pressure setting.

Visit www.sunhydraulics.com for detailed and complete technical information on our full line of products.

VENTABLE, PILOT OPERATED, BALANCED PISTON, RELIEF VALVE - BEFORE CHECK

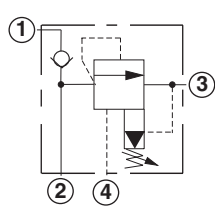
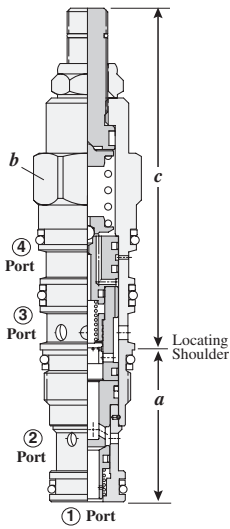

Capacity	Typical Cartridge Model Code	Cavity	Cartridge Dimensions					Installation Torque (Nm)
			a	b	L	C	K	
40 L/min.	HVCA - LAN	T - 21A	35,0	22,2	78,9	80,2	85,0	45/50

Performance Curves

HVCA

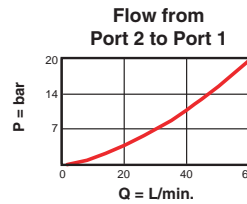
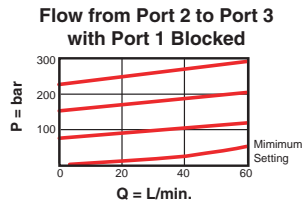

- Maximum operating pressure = 350 bar
- Maximum valve leakage (port 2 to port 3) = 32,8 cc/min. at 70 bar
- Factory pressure setting established at 15 L/min.
- Free flow check cracking pressure = 1,7 bar
- Typical response = 10 ms
- Minimum setting is 5 bar for all spring ranges.
- Back pressure at port 3 (tank) is directly additive to the valve setting at a 1:1 ratio.
- Pressure at port 4 (vent) controls the valve below its setting.
- The check portion of the valve has a maximum leakage rate of less than 0,07 cc/min.
- Note: This valve deviates from Sun's normal flow path for four port relief valves; port 2 is the inlet, port 1 is the system, port 3 is tank and port 4 is vent. Therefore, it is probably not useable in existing standard Sun relief manifolds.

HVCA - LAN

Nominal Capacity	Control**	Adjustment Range	Seal
C 40 L/min.	L Standard Screw Adjustment	A 5 - 210 bar	N Buna-N
	C Tamper Resistant Factory Set	B 5 - 105 bar	V Viton
	K Handknob	D 5 - 55 bar	
		W 5 - 315 bar	

** See page 162 for information on Control Options

Customer may specify pressure setting.

Visit www.sunhydraulics.com for detailed and complete technical information on our full line of products.

VENTABLE, PILOT OPERATED, BALANCED PISTON, RELIEF VALVE - BEFORE CHECK WITH INTEGRAL PILOT CONTROL CAVITY

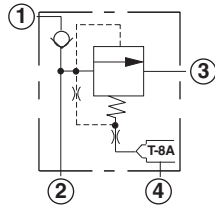
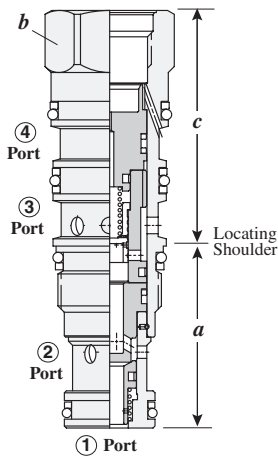

The -8 control option allows the pilot control valve to be incorporated directly into the end of the relief cartridge via the T-8A cavity. These pilot control cartridges are sold separately and include electro-proportional, solenoid, air pilot, and hydraulic pilot operation. See Pilot Control Cartridges on page 121.

Capacity	Typical Cartridge Model Code	Cavity	Cartridge Dimensions			Installation Torque (Nm)
			a	b	c	
40 L/min.	HVCA - 8DN	T - 21A	35,0	22,2	45,2	45/50

Performance Curves

HVCA-8

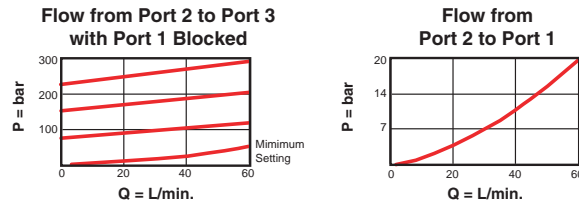

- Maximum operating pressure = 350 bar
- Maximum valve leakage (port 2 to port 3) = 32,8 cc/min. at 70 bar
- Free flow check cracking pressure = 1,7 bar
- Minimum setting is 5 bar for all spring ranges.
- Back pressure at port 4 (tank) is directly additive to the valve setting at a 1:1 ratio.
- The check portion of the valve has a maximum leakage rate of less than 0,07 cc/min.
- Note: This valve deviates from Sun's normal flow path for four port relief valves; port 2 is the inlet, port 1 is the system, port 3 is tank and port 4 is vent. Therefore, it is probably not useable in existing standard Sun relief manifolds.
- With the -8 control option, the main stage valve should first be installed to the correct torque value. The T-8A pilot control valve should then be installed into the main stage valve to its required torque value.

HVCA - 8DN

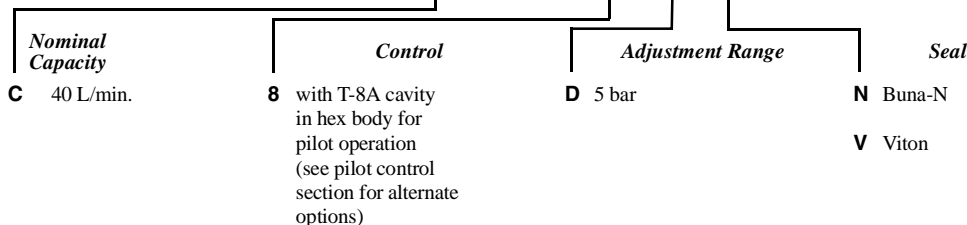

Visit www.sunhydraulics.com for detailed and complete technical information on our full line of products.

NOTES

General Information

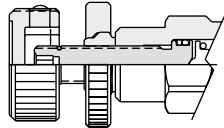
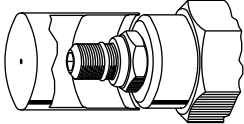
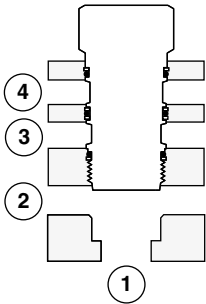
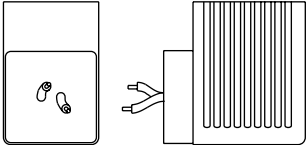
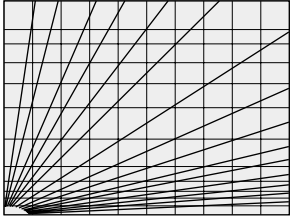
	<i>Page</i>	
Cartridge Control Options	162	
Cartridge Control Kits	163	
Cavity Plugs	165	
Solenoid Electrical Connector Options	167	
Orifice Pressure Drop Data	168	

Cartridge Control Options

General Purpose Controls (for use in systems where adjustment may be changed after installation.)

L Standard Screw Adjustment

O-ring seal on adjust screw. Adjust screw positively retained. Overset protection-pilot spring cannot go solid.

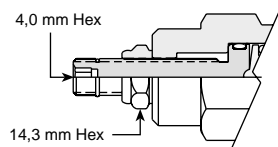

K Handknob with Lock Knob

Handknob and lock knob added to L control. Sun handknob kits for field conversion are available.

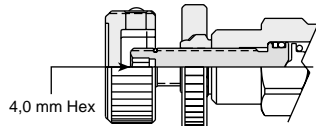

O Handknob with Panel Mount

Special threaded cartridge hex body with panel nut for mounting cartridge through access hole in control panel. Handknob and lock knob included.

Panel Hole:

Series 1 cartridges 190 mm dia.
Series 2 cartridges 25,4 mm dia.
Panel nut hex size identical to cartridge hex size.

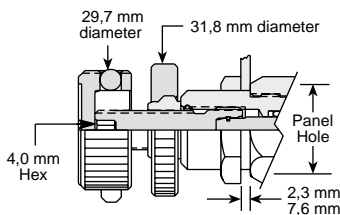

Key Lock Kit

Optional adjustment Key Lock Cover Kit for L controls allows adjustment to be locked with a key to prevent unauthorized changes in valve setting. Adjustment is easily accessible when lock assembly is removed. Requires replacement of standard locknut with special locknut which accepts lock assembly, and a new wire stop ring for overset protection.

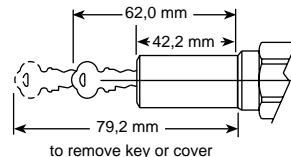

H Calibrated Handknob with Detent Lock

Fully calibrated handknob for flow control cartridges. 40 radial calibrations per turn. Moveable zero indicator. (Minor disassembly required.) Rising detented locking collar positively locks adjustment knob against vibration or accidental tampering. Any desired setting may be recorded and repeated. U.S. Patent #4,577,831.

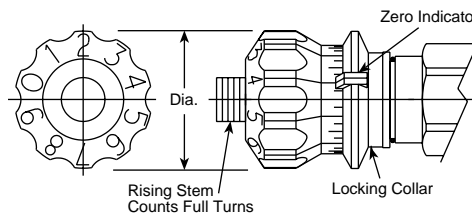

Diameter	28,7 mm	35,1 mm	41,1 mm	41,1 mm
Series	1	2	3	4
	NCCB	NCEB	NCFB	NCEB
	NCCC	NCEC	NCFC	NCEC
	NFCC	NFDC	NFEC	NFCC
	NFCD	NFDD	NFED	NFDD
	FDBA	FDCB	FDEA	FDFB

C Tamper Resistant Factory Set

Cover press-fit onto L control cartridge shoulder. Valves may be ordered in this configuration from Sun. **Specify pressure setting on order.** Setting stamped on cartridge hex. Sun kits for field conversion are available.

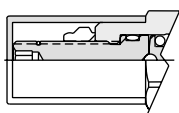

Special Purpose Controls (for use in systems where adjustment is seldom changed after installation)

J Socket Head Set Screw with Cap

Stem seal - Seal under locknut. Adjusting screw not retained. No overset protection.

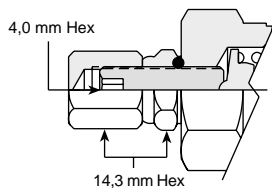

F Wrench Adjustment

Stem seal - Seal under locknut. Adjusting screw is not retained. Overset protection-pilot spring cannot go solid.

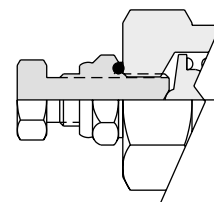

Counterbalance Cartridge Controls

All Sun counterbalance cartridges are built with a leakproof adjustment - O-ring seals are on the adjusting screw-but are not designed for frequent adjustment in the field. Cartridges that are factory pre-set by Sun to a customer specified pressure setting are available and can be installed directly on a machine without the need for further adjustment.

C Tamper Resistant Factory Set

See "C" Control description above.

L Standard Leakproof

Screw Adjustment.
O-ring seal on adjust screw.

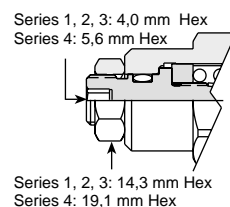

Visit www.sunhydraulics.com for detailed and complete technical information on our full line of products.

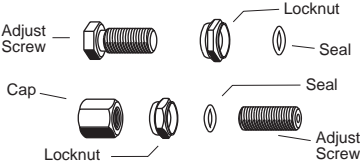
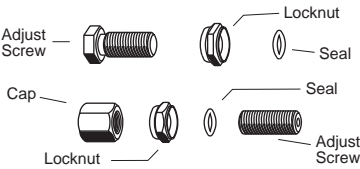
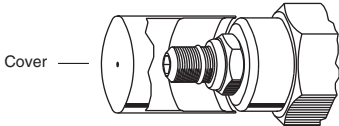
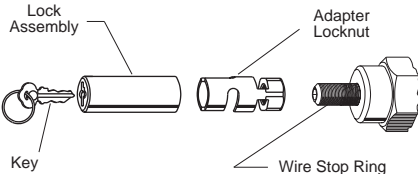
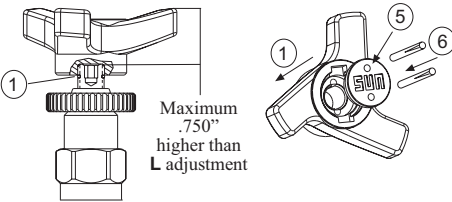
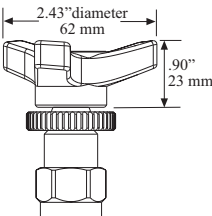
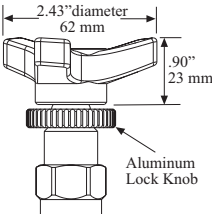

Cartridge Control Kits

Service Kit Number Description	Use specifically with Control/Cartridge	Description	Notes
Adjustment Screw Kit 991-006	All F controls		To assure a complete seal on the stem - release all pressure on the cartridge after setting. Then... tighten locknut (and cap, on J).
Adjustment Screw Kit 991-010	All J controls		
Tamper Resistant Cover 991-000	For all Sun cartridges with L adjustment Series 0 - hex 19,0 mm 991-004 Series 1 - 22,2 mm hex 991-001 Series 2 - 28,6 mm hex 991-002 Series 3 - 31,8 mm hex 991-003 Series 4 - 41,0 mm hex 991-032 Series 1 - 22,2 mm hex (CB**, CC**) 991-033 Series 2 - 28,6 mm hex (CB**, CC**)		<ol style="list-style-type: none"> 1. Adjust valve to desired setting and tighten locknut. 2. Using an arbor press or a soft hammer, install cover until it seats on cartridge hex. 3. Cover is a press fit on cartridge shoulder.
Key Lock Kit 993-008	For all Sun cartridges with L adjustment (except Series 0 and counterbalance cartridges).		<ol style="list-style-type: none"> 1. Remove original wire stop ring and locknut. 2. Thread on the adapter locknut and install new wire stop ring through slot provided. 3. Adjust valve to desired setting and tighten adapter locknut. 4. Slide lock assembly over adapter, lock and remove key.
Three-winged Handknob Kit 991-034	For all Series 1, 2, 3, 4 valves with L or O adjustment except counterbalance cartridges.	<p>Install while cartridge is screwed in cavity to prevent damage.</p> 	<ol style="list-style-type: none"> 1. Do not remove stop ring. 2. Install lock knob by snapping onto the locknut. 3. Install star knob until contact is made with the stop ring. 4. Caution during installation on flow control valves (that have no stop ring). Make sure valve can be shut with hand knob installed. 5. Insert pins in cover so that they project on backside. 6. Put cover on with inserted pins and drive pins in until flush with cover.
	The handknob can be used as a Maximum Setting Limiter.		<p>When knob is used as a maximum Setting Limiter:</p> <ol style="list-style-type: none"> 1. Set valve at desired maximum setting. 2. Tighten lock nut (110 lbs. inch). 3. Remove stop ring. 4. Install lock knob. 5. Install handknob until flush with the lock knob.
Three-winged Handknob Kit with 1 3/8" dia. aluminum lock knob. 991-039	This kit should be used in applications where there is high vibration and a plastic lock knob may loosen.		Follow installation instructions described above.

Cartridge Control Kits continue on next page

Visit www.sunhydraulics.com for detailed and complete technical information on our full line of products.

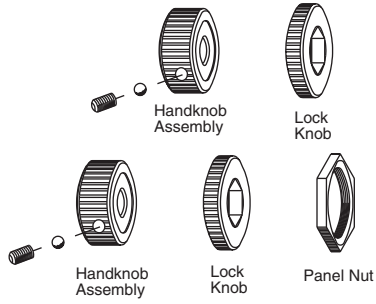
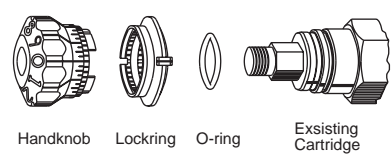
Cartridge Control Kits

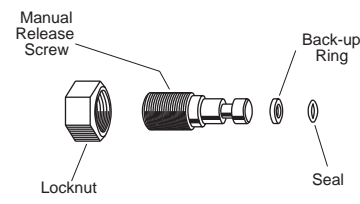
Service Kit Number Description	Use specifically with Control/Cartridge	Description	Notes
K Handknob Kit 991-211 991-222 Panel Handknob Kit 991-215 Panel Handknob Kit 991-216	Use this kit to adapt all L controls to K controls (except Series 0 and counterbalance cartridges). K control for Series 0 O controls All Series 1 cartridges 22,2 mm hex M20 thread O controls All Series 2 cartridges 28,6 mm hex 1"-14 thread		Only cartridges date stamped "41" or later and originally supplied with plastic knobs. Lock knob snaps onto locknut furnished on cartridge.
H Calibrated Handknob Kit 991-219 991-220 991-221	H controls All series of flow controls FDCB, NCEB, NCEC, NFDC, NFDD only FDEA, FDFA, NCFB, NCFC, NCEB, NCEC, NFEC, NFED, NFEC, NFED, NFEC, NFED only FDBA, NCCB, NCCC, NFCC, NFDC only		Only for cartridges originally supplied with an H handknob. Valves can not be modified in the field. Note: The H control is Only available for the cartridges shown to the left.
Lockwire Kit 991-012	All M, Q and R controls (except solenoid operated cartridges).		
Adjustment Screw Kit 991-112-003 Viton 991-112-007 Buna-N Adjustment Screw Kit 991-212-003 Viton 991-212-007 Buna-N	CKCA L**CKCD L** CKCB L**CPCA L** CKCC L** CKEA L**CKED L** CKEB L**CPEA L** CKEC L**		Only cartridges date stamped "62" or earlier.

Visit www.sunhydraulics.com for detailed and complete technical information on our full line of products.

Cavity Plugs

It is sometimes desirable to remove a Sun cartridge valve and still maintain the integrity of the hydraulic system. This may be necessitated by the need to flush a system after repairs or a piping change, or to change an operating function in the circuit. For these requirements, Sun offers two styles of cavity plugs - all ports blocked and main ports open to flow.

Plugs for Two Port Cavities:

Series	Cavity	All Ports Open			All Ports Blocked		
		Cavity Plug Model Code*	Buna-N	Viton	Cavity Plug Model Code	Buna-N	Viton
P	T-8A	XAOA-XX*			XACA-XX*		
0	T-162A	XZOA-XX*			XZCB-XX*		
1	T-10A	XFOA-XX*			XFCA-XX*		
	T-13A					XGCA-XX*	
2	T-3A	XCOA-XX*			XCCA-XX*		
	T-5A					XDCA-XX*	
3	T-16A	XIOA-XX*			XICA-XX*		
4	T-18A	XKOA-XX*			XKCA-XX*		

Plugs for Three Port Cavities

Series	Cavity	Ports 1 to 2 Open Port 3 Blocked			All Ports Blocked		
		Cavity Plug Model Code*	Buna-N	Viton	Cavity Plug Model Code	Buna-N	Viton
P	T-9A	XAOB-XX*			XACBXX*		
0	T-163A	XZOB-XX*			XZCB-XX*		
1	T-11A	XEOA-XX*			XECA-XX*		
2	T-2A	XBOA-XX*			XBCA-XX*		
3	T-17A	XHOA-XX*			XHCA-XX*		
4	T-19A	XJOA-XX*			XJCA-XX*		

Plugs for Four Port Cavities (Internal Locating Shoulder)

Series	Cavity	Ports 1 to 2 Open Port 3 and 4 Blocked			All Ports Blocked		
		Cavity Plug Model Code*	Buna-N	Viton	Cavity Plug Model Code	Buna-N	Viton
1	T-21A	XMOA-XX*			XMCA-XX*		
2	T-22A	XNOA-XX*			XNCA-XX*		
3	T-23A	XPOA-XX*			XPCA-XX*		
4	T-24A	XQOA-XX*			XQCA-XX*		

*Insert in the seventh position model code digit N to order Buna-N seals or V to order Viton seals.

Visit www.sunhydraulics.com for detailed and complete technical information on our full line of products.

Cavity Plugs

Plugs for Four Port Cavities (External Locating Shoulder)

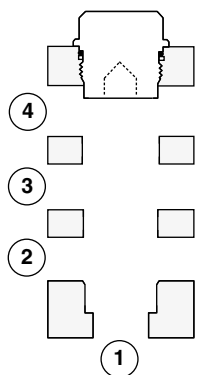

Series	Cavity	All Ports Open		All Ports Blocked			
		Cavity Plug Model Code*	Buna-N	Viton	Cavity Plug Model Code*	Buna-N	Viton
1	T-31A	XFOA-XX*			XRCA-XX*		
2	T-32A	XCOA-XX*			XSCA-XX*		
3	T-33A	XIOA-XX*			XTCA-XX*		
4	T-34A	XKOA-XX*			XVCA-XX*		

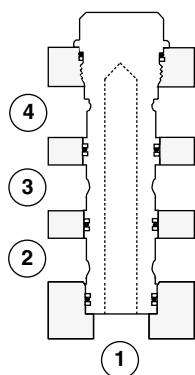

Plugs for Six Port Cavities

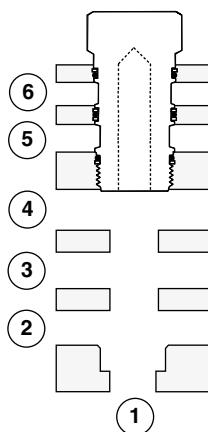

Series	Cavity	Ports 1, 2, 3 and 4 Open Ports 5 and 6 Blocked		All Ports Blocked			
		Cavity Plug Model Code*	Buna-N	Viton	Cavity Plug Model Code*	Buna-N	Viton
1	T-61A	XMOA-XX*			XRCC-XX*		
2	T-62A	XNOA-XX*			XSCC-XX*		
3	T-63A	XPOA-XX*			XTCC-XX*		
4	T-64A	XQOA-XX*			XVCC-XX*		

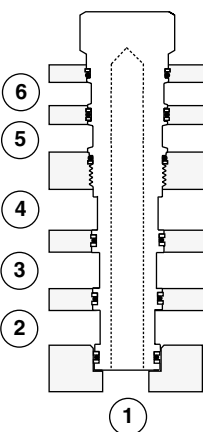

Cavity Adaptor (Converts Waterman 12-2 Cavity to the Sun T-8A Cavity)

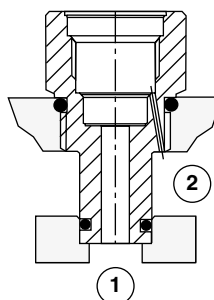

Cavity	All Ports Open		
	Cavity Plug Model Code*	Buna-N	Viton
12-2	XAAA-8X*		

*Insert in the seventh position model code digit N to order Buna-N seals or V to order Viton seals.

Visit www.sunhydraulics.com for detailed and complete technical information on our full line of products.

Sun Solenoid Electrical Connector Options

Sun Hydraulics has a range of pilot flow and full flow solenoid products with operating pressures up to 350 bar. These products are available with the coil configuration options shown below. If you only require pilot flow and want to operate these packages in a 350 bar system, Sun offers a screw-in adapter that converts the Waterman 12-2 cavity to a Sun T-8A cavity.

Connector Options for Sun Pilot Flow Solenoid Valves (DAAA, DBAA)

ISO / DIN 43650

SAE J858-A

Twin Lead

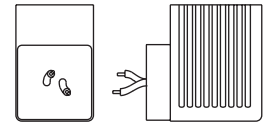
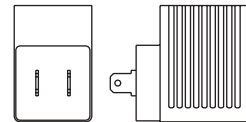
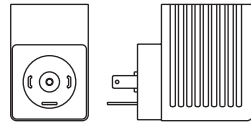

Description	Coil only part number	Coil only part number	Coil only part number
115 V AC 50/60 Hz	760-211	N/A	N/A
230 V AC 50/60 Hz	760-223	N/A	N/A
6 V DC	760-206	760-506	760-706
12 V DC	760-212	760-512	760-712
24 V DC	760-224	760-524	760-724
28 V DC	760-228	760-528	760-728
36 V DC	760-236	760-536	760-736
48 V DC	760-248	760-548	760-748

Connector Options for Sun Full Flow Solenoid Valves (DLDA, DTDA, DMDA, DNDA) and Proportional Valves (RBAP, PRDP, PRDL)

ISO/DIN 43650

Twin Spade
(SAE J858A)

AMP® Junior Timer

Twin Lead

Metri-Pack

Deutsch

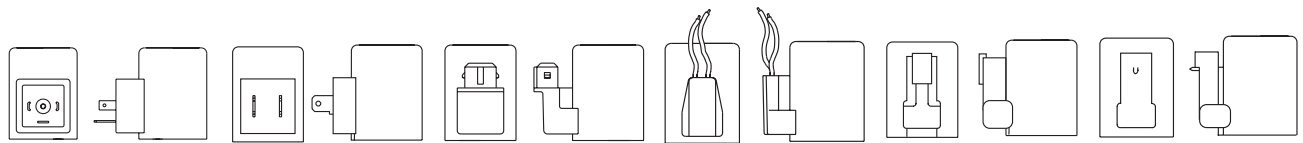

Description	Coil only part number	Coil only part number	Coil only part number	Coil only part number	Coil only part number	Coil only part number
115 V AC 50/60 Hz	770-211	N/A	N/A	N/A	N/A	N/A
230 V AC 50/60 Hz	770-223	N/A	N/A	N/A	N/A	N/A
12 V DC	770-212	770-512	770-612	770-712	770-812	770-912
24 V DC	770-224	770-524	770-624	770-724	770-824	770-924
48VDC	770-248	770-548	770-648	770-748	770-848	770-948

Visit www.sunhydraulics.com for detailed and complete technical information on our full line of products.

ORIFICE PRESSURE DROP DATA

No allowance has been made for viscosity effects, or regain of pressure downstream.

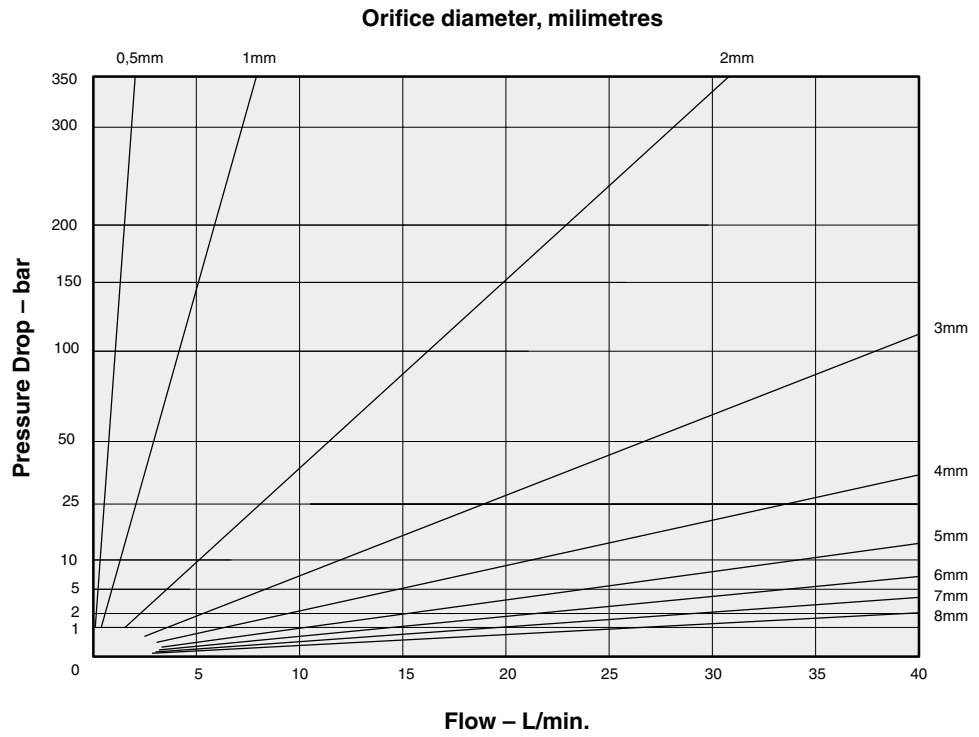

These charts are based on the formula:

$$Q = \alpha A \sqrt{\frac{2AP}{\rho}}$$

Where:

- Q = Flow m³/sec.
- α = orifice coefficient
- A = orifice dia. cm²
- ΔP = pressure drop N/m²
- ρ = density Ns²/m⁴

This equation becomes:

$$Q \text{ (l,min)} = 0.4212 \times d^2 \text{ (mm)} \sqrt{\text{pressure drop (bar)}}$$

when c = 0.6
ρ = 0.9 g/cm³

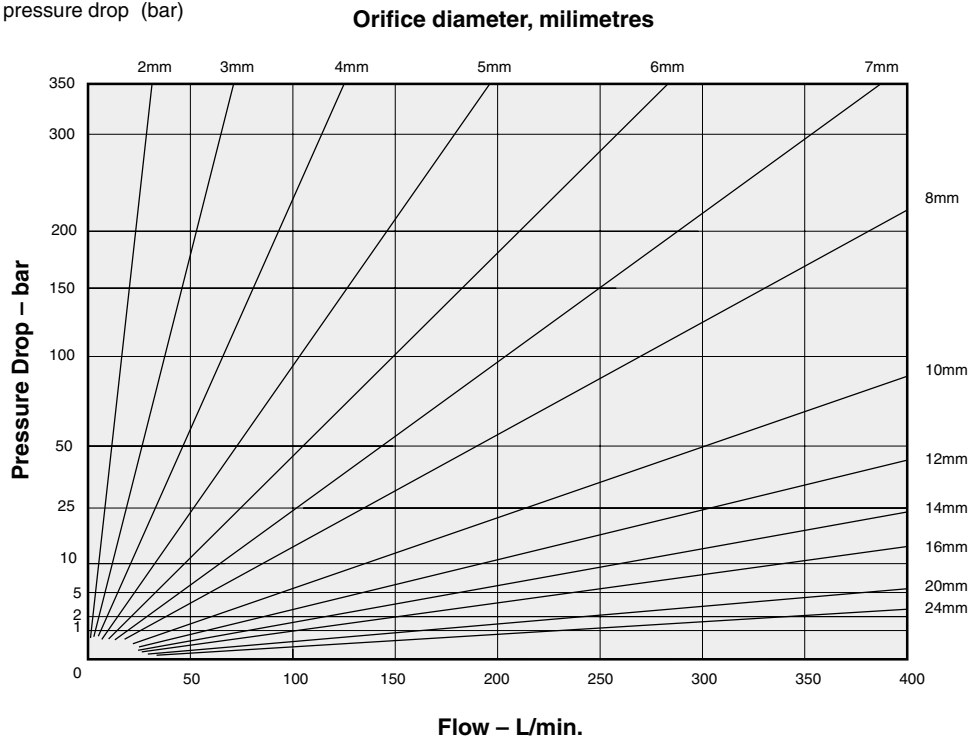

Model Code Index

<i>Model Code</i>	<i>Cavity</i>	<i>Page</i>	<i>Model Code</i>	<i>Cavity</i>	<i>Page</i>	<i>Model Code</i>	<i>Cavity</i>	<i>Page</i>
CACA - ***	T-11A	55	CBGL - ***	T-17A	49	COJA - ***	T-19A	147
CACG - ***	T-11A	55	CBGY - ***	T-17A	48	CSAA - ***	T-13A	136
CACK - ***	T-11A	55	CBHA - ***	T-19A	53	CSAB - ***	T-11A	137
CACL - ***	T-11A	55	CBHG - ***	T-19A	53	CSAC - ***	T-13A	136
CAEA - ***	T-2A	55	CBIA - ***	T-19A	48	CSAD - ***	T-11A	137
CAEG - ***	T-2A	55	CBIB - ***	T-19A	48	CSAW - ***	T-162A	136
CAEK - ***	T-2A	55	CBIG - ***	T-19A	49	CSAX - ***	T-163A	137
CAEL - ***	T-2A	55	CBIH - ***	T-19A	49	CSAY - ***	T-162A	136
CAGA - ***	T-17A	55	CBIL - ***	T-19A	49	CSAZ - ***	T-163A	137
CAGG - ***	T-17A	55	CBIY - ***	T-19A	48	CVCV - ***	T-21A	46
CAGK - ***	T-17A	55	CCCA - ***	T-11A	54	CVEV - ***	T-22A	46
CAGL - ***	T-17A	55	CCEA - ***	T-2A	54	CVGV - ***	T-23A	46
CAIA - ***	T-19A	55	CCGA - ***	T-17A	54	CVIV - ***	T-24A	46
CAIG - ***	T-19A	55	CCIA - ***	T-19A	54	CWCA - ***	T-21A	56
CAIK - ***	T-19A	55	CDAA - ***	T-13A	138	CWCG - ***	T-21A	57
CAIL - ***	T-19A	55	CDAB - ***	T-11A	139	CWCK - ***	T-21A	56
CBBA - ***	T-11A	52	CDAC - ***	T-13A	138	CWCL - ***	T-21A	57
CBBB - ***	T-11A	50	CDAD - ***	T-11A	139	CWEA - ***	T-22A	56
CBBC - ***	T-11A	50	CKBB - ***	T-163A	44	CWEG - ***	T-22A	57
CBBD - ***	T-11A	51	CKBD - ***	T-163A	44	CWEK - ***	T-22A	56
CBBG - ***	T-11A	53	CKCB - ***	T-11A	44	CWEL - ***	T-22A	57
CBBL - ***	T-11A	51	CKCD - ***	T-11A	44	CWGA - ***	T-23A	56
CBBY - ***	T-11A	52	CKCV - ***	T-11A	45	CWGG - ***	T-23A	57
CBCA - ***	T-11A	48	CKEB - ***	T-2A	44	CWGK - ***	T-23A	56
CBCB - ***	T-11A	48	CKED - ***	T-2A	44	CWGL - ***	T-23A	57
CBCG - ***	T-11A	49	CKEV - ***	T-2A	45	CWIA - ***	T-24A	56
CBCH - ***	T-11A	49	CKGB - ***	T-17A	44	CWIG - ***	T-24A	57
CBCL - ***	T-11A	49	CKGD - ***	T-17A	44	CWIK - ***	T-24A	56
CBCY - ***	T-11A	48	CKGV - ***	T-17A	45	CWIL - ***	T-24A	57
CBDA - ***	T-2A	52	CKIB - ***	T-19A	44	CXAD - ***	T-162A	61
CBDB - ***	T-2A	50	CKID - ***	T-19A	44	CXBA - ***	T-162A	60
CBDC - ***	T-2A	50	CKIV - ***	T-19A	45	CXCD - ***	T-13A	61
CBDD - ***	T-2A	51	CNAC - ***	T-162A	72	CXCE - ***	T-11A	62
CBDG - ***	T-2A	53	CNBC - ***	T-162A	63	CXDA - ***	T-13A	60
CBDL - ***	T-2A	51	CNCC - ***	T-13A	72	CXED - ***	T-5A	61
CBEA - ***	T-2A	48	CNCD - ***	T-11A	64	CXEE - ***	T-2A	62
CBEB - ***	T-2A	48	CNDC - ***	T-13A	63	CXFA - ***	T-5A	60
CBEG - ***	T-2A	49	CNEC - ***	T-5A	72	CXGD - ***	T-16A	61
CBEH - ***	T-2A	49	CNED - ***	T-2A	64	CXGE - ***	T-17A	62
CBEL - ***	T-2A	49	CNFC - ***	T-5A	63	CXHA - ***	T-16A	60
CBEY - ***	T-2A	48	CNGC - ***	T-16A	72	CXID - ***	T-18A	61
CBFA - ***	T-17A	52	CNGD - ***	T-17A	64	CXIE - ***	T-19A	62
CBFB - ***	T-17A	50	CNHC - ***	T-16A	63	CXJA - ***	T-18A	60
CBFC - ***	T-17A	50	CNIC - ***	T-18A	72	DAAA - ***	T-8A	118
CBFD - ***	T-17A	51	CNID - ***	T-19A	64	DAAA - ***	T-8A	122
CBFG - ***	T-17A	53	CNJC - ***	T-18A	63	DAAC - ***	T-8A	118
CBFL - ***	T-17A	51	COBA - ***	T-163A	147	DAAC - ***	T-8A	122
CBGA - ***	T-17A	48	CODA - ***	T-11A	147	DAAH - ***	T-8A	123
CBGB - ***	T-17A	48	COFA - ***	T-2A	147	DAAP - ***	T-8A	124
CBGG - ***	T-17A	49	COFO - ***	T-2A	146	DAAM - ***	T-8A	125
CBGH - ***	T-17A	49	COHA - ***	T-17A	147	DBAA - ***	T-9A	119

<i>Model Code</i>	<i>Cavity</i>	<i>Page</i>	<i>Model Code</i>	<i>Cavity</i>	<i>Page</i>	<i>Model Code</i>	<i>Cavity</i>	<i>Page</i>
DBAA - ***	T-9A	126	DOJP - ***	T-24A	96	DVBM - 8**	T-21A	107
DBAC - ***	T-9A	119	DOJR - ***	T-24A	94	DVBN - 8**	T-21A	107
DBAC - ***	T-9A	126	DOJR - 8**	T-24A	95	DVBO - 8**	T-21A	107
DBAH - ***	T-9A	127	DOJS - ***	T-24A	93	DVBP - 8**	T-21A	107
DBAM - ***	T-9	122	DPBA - ***	T-11A	102	FCBB - ***	T-162A	70
DBAP - ***	T-9A	128	DPBB - ***	T-11A	102	FCCB - ***	T-13A	70
DCCC - ***	T-61A	110	DPBC - ***	T-11A	102	FCDB - ***	T-5A	70
DCCD - ***	T-61A	111	DPBD - ***	T-11A	102	FCEB - ***	T-16A	70
DCDC - ***	T-62A	110	DPBM - ***	T-21A	103	FCFB - ***	T-18A	70
DCDD - ***	T-62A	111	DPBN - ***	T-21A	103	FDBA - ***	T-13A	71
DCEC - ***	T-63A	110	DPBO - ***	T-21A	103	FDCB - ***	T-5A	71
DCED - ***	T-63A	111	DPBP - ***	T-21A	103	FDEA - ***	T-16A	71
DCFC - ***	T-64A	110	DPCA - ***	T-2A	102	FDFA - ***	T-18A	71
DCFD - ***	T-64A	111	DPCB - ***	T-2A	102	FPCC - ***	T-13A	73
DFCA - 8**	T-13A	108	DPCC - ***	T-2A	102	FPCH - ***	T-13A	74
DFCB - 8**	T-13A	109	DPCD - ***	T-2A	102	FQCA - ***	T-13A	144
DFDA - 8**	T-5A	108	DPCM - ***	T-22A	103	FQEA - ***	T-5A	144
DFDB - 8**	T-5A	109	DPCN - ***	T-22A	103	FQGA - ***	T-16A	144
DFEA - 8**	T-16A	108	DPCO - ***	T-22A	103	FQIA - ***	T-18A	144
DFEB - 8**	T-16A	109	DPCP - ***	T-22A	103	FRBA - ***	T-163A	76
DFFA - 8**	T-18A	108	DRAX - ***	T-21A	150	FRCA - ***	T-11A	76
DKDP - ***	T-21A	98	DRAY - ***	T-21A	151	FRDA - ***	T-2A	76
DKDR - ***	T-21A	99	DRBA - ***	T-11A	104	FREA - ***	T-17A	76
DKDR - 8**	T-21A	100	DRBB - ***	T-11A	104	FRFA - ***	T-19A	76
DKDS - ***	T-21A	97	DRBC - ***	T-11A	104	FSBA - ***	T-31A	83
DKFP - ***	T-22A	98	DRBD - ***	T-11A	104	FSBD - ***	T-31A	82
DKFR - ***	T-22A	99	DRBR - ***	T-21A	105	FSBS - ***	T-31A	84
DKFR - 8**	T-22A	100	DSCH - ***	T-31A	140	FSCA - ***	T-31A	83
DKFS - ***	T-22A	97	DSCO - ***	T-31A	142	FSCD - ***	T-31A	82
DKHP - ***	T-23A	98	DSCS - ***	T-31A	141	FSCH - ***	T-31A	85
DKHR - ***	T-23A	99	DSCX - ***	T-31A	152	FSCS - ***	T-31A	84
DKHR - 8**	T-23A	100	DSCY - ***	T-31A	153	FSDA - ***	T-32A	83
DKHS - ***	T-23A	97	DSEH - ***	T-32A	140	FSDD - ***	T-32A	82
DKJP - ***	T-24A	98	DSEO - ***	T-32A	142	FSDH - ***	T-32A	85
DKJR - ***	T-24A	99	DSES - ***	T-32A	141	FSDS - ***	T-32A	84
DKJR - 8**	T-24A	100	DSEX - ***	T-32A	152	FSEA - ***	T-33A	83
DKJS - ***	T-24A	97	DSEY - ***	T-32A	153	FSED - ***	T-33A	82
DLDA - ***	T-13A	114	DSGH - ***	T-33A	140	FSEH - ***	T-33A	85
DMDA - ***	T-11A	116	DSGO - ***	T-33A	142	FSES - ***	T-33A	84
DNDA - ***	T-31A	117	DSGS - ***	T-33A	141	FSFA - ***	T-34A	83
DODP - ***	T-21A	96	DSGX - ***	T-33A	152	FSFD - ***	T-34A	82
DODR - ***	T-21A	94	DSGY - ***	T-33A	153	FSFH - ***	T-34A	85
DODR - 8**	T-21A	95	DSIH - ***	T-34A	140	FSFS - ***	T-34A	84
DODS - ***	T-21A	93	DSIO - ***	T-34A	142	FVCA - ***	T-21A	77
DOFP - ***	T-22A	96	DSIS - ***	T-34A	141	FVCA - 8**	T-21A	78
DOFR - ***	T-22A	94	DSIX - ***	T-34A	152	FVDA - ***	T-22A	77
DOFR - 8**	T-22A	95	DSIY - ***	T-34A	153	FVDA - 8**	T-22A	78
DOFS - ***	T-22A	93	DTDA - ***	T-13A	115	FVEA - ***	T-23A	77
DOHP - ***	T-23A	96	DVBA - 8**	T-11A	106	FVEA - 8**	T-23A	78
DOHR - ***	T-23A	94	DVBB - 8**	T-11A	106	FVFA - ***	T-24A	77
DOHR - 8**	T-23A	95	DVBC - 8**	T-11A	106	FVFA - 8**	T-24A	78
DOHS - ***	T-23A	93	DVBD - 8**	T-11A	106	FXBA - ***	T-162A	69

CARTRIDGES

<i>Model Code</i>	<i>Cavity</i>	<i>Page</i>	<i>Model Code</i>	<i>Cavity</i>	<i>Page</i>	<i>Model Code</i>	<i>Cavity</i>	<i>Page</i>
FXCA - ***	T-13A	69	LPBC - ***	T-163A	91	PPDB - 8**	T-11A	38
FXDA - ***	T-5A	69	LPDA - ***	T-11A	91	PPFB - ***	T-2A	31
FXEA - ***	T-16A	69	LPDC - ***	T-11A	91	PPFB - 8**	T-2A	38
FXFA - ***	T-18A	69	LPFA - ***	T-2A	91	PPFC - ***	T-2A	36
HRDA - ***	T-11A	156	LPFC - ***	T-2A	91	PPHB - ***	T-17A	31
HRDB - ***	T-11A	157	LPHA - ***	T-17A	91	PPHB - 8**	T-17A	38
HVCA - ***	T-21A	158	LPHC - ***	T-17A	91	PPHC - ***	T-17A	36
HVCA - 8**	T-21A	159	LPJA - ***	T-19A	91	PPJB - ***	T-19A	31
LHDA - ***	T-31A	79	LPJC - ***	T-19A	91	PPJB - 8**	T-19A	38
LHDT - ***	T-31A	154	LRBA - ***	T-163A	92	PPJC - ***	T-19A	36
LHFA - ***	T-32A	79	LRBC - ***	T-163A	92	PRDB - ***	T-11A	32
LHFT - ***	T-32A	154	LRDA - ***	T-11A	92	PRDL - ***	T-11A	40
LHHA - ***	T-33A	79	LRDC - ***	T-11A	92	PRDP - ***	T-11A	41
LHHT - ***	T-33A	154	LRFA - ***	T-2A	92	PRFB - ***	T-2A	32
LHJA - ***	T-34A	79	LRFC - ***	T-2A	92	PRHB - ***	T-17A	32
LKDC - ***	T-11A	90	LRHA - ***	T-17A	92	PRJB - ***	T-19A	32
LKFC - ***	T-2A	90	LRHC - ***	T-17A	92	PVDA - ***	T-21A	33
LKHC - ***	T-17A	90	LRJA - ***	T-19A	92	PVDA - 8**	T-21A	39
LKJC - ***	T-19A	90	LRJC - ***	T-19A	92	PVDB - ***	T-21A	34
LODA - ***	T-11A	88	NCBB - ***	T-162A	68	PVFA - ***	T-22A	33
LODA - 8**	T-11A	89	NCCC - ***	T-13A	68	PVFA - 8**	T-22A	39
LODB - ***	T-11A	88	NCEB - ***	T-5A	68	PVFB - ***	T-22A	34
LODB - 8**	T-11A	89	NCCB - ***	T-13A	68	PVHA - ***	T-23A	33
LODC - 8**	T-11A	88	NCEC - ***	T-5A	68	PVHA - 8**	T-23A	39
LODD - ***	T-11A	88	NCFB - ***	T-16A	68	PVHB - ***	T-23A	34
LODD - 8**	T-11A	89	NCFC - ***	T-16A	68	PVJA - ***	T-24A	33
LODO - ***	T-11A	88	NCGB - ***	T-18A	68	PVJA - 8**	T-24A	39
LOFA - ***	T-2A	88	NCGC - ***	T-18A	68	PVJB - ***	T-24A	34
LOFA - 8**	T-2A	89	NFAB - ***	T-8A	132	QCDA - ***	T-21A	149
LOFB - ***	T-2A	88	NFBC - ***	T-162A	66	QCDB - ***	T-21A	149
LOFB - 8**	T-2A	89	NFCC - ***	T-13A	66	QCDC - ***	T-21A	149
LOFC - ***	T-2A	88	NFCD - ***	T-13A	67	QCDD - ***	T-21A	149
LOFD - ***	T-2A	88	NFDC - ***	T-5A	66	QCDD - ***	T-21A	149
LOFD - 8**	T-2A	89	NFDD - ***	T-5A	67	QPAA - ***	T-11A	148
LOFO - ***	T-2A	88	NFEC - ***	T-16A	66	QPAB - ***	T-11A	148
LOHA - ***	T-17A	88	NFED - ***	T-16A	67	QPAC - ***	T-11A	148
LOHA - 8**	T-17A	89	NFFC - ***	T-18A	66	QPAD - ***	T-11A	148
LOHB - ***	T-17A	88	NFFD - ***	T-18A	67	RBAA - ***	T-3A	8
LOHB - 8**	T-17A	89	NQEB - ***	T-3A	145	RBAC - ***	T-10A	8
LOHC - ***	T-17A	88	PBBB - ***	T-163A	30	RBAE - ***	T-8A	130
LOHD - ***	T-17A	88	PBDB - ***	T-11A	30	RBAP - ***	T-8A	13
LOHD - 8**	T-17A	89	PBDB - 8**	T-11A	37	RBAP - ***	T-8A	133
LOHO - ***	T-17A	88	PBFB - ***	T-2A	30	RBAR - ***	T-8A	131
LOJA - ***	T-19A	88	PBFB - 8**	T-2A	37	RDBA - ***	T-162A	7
LOJA - 8**	T-19A	89	PBFC - ***	T-2A	35	RDDA - ***	T-10A	7
LOJB - ***	T-19A	88	PBHB - ***	T-17A	30	RDFA - ***	T-3A	7
LOJB - 8**	T-19A	89	PBHB - 8**	T-17A	37	RDHA - ***	T-16A	7
LOJC - ***	T-19A	88	PBHC - ***	T-17A	35	RDJA - ***	T-18A	7
LOJD - ***	T-19A	88	PBJB - ***	T-19A	30	RPCC - ***	T-162A	6
LOJD - 8**	T-19A	89	PBJB - 8**	T-19A	37	RPCC - 8**	T-162A	14
LOJO - ***	T-19A	88	PBJC - ***	T-19A	35	RPEC - ***	T-10A	6
LPBA - ***	T-163A	91	PPDB - ***	T-11A	31	RPEC - 8**	T-10A	14



Model Code Index

<i>Model Code</i>	<i>Cavity</i>	<i>Page</i>	<i>Model Code</i>	<i>Cavity</i>	<i>Page</i>	<i>Model Code</i>	<i>Cavity</i>	<i>Page</i>
RPGC - ***	T-3A	6	RSFC - 8**	T-2A	23	RVGA - ***	T-17A	16
RPGC - 8**	T-3A	14	RSFE - ***	T-2A	24	RVGB - ***	T-17A	17
RPGD - ***	T-3A	12	RSHC - ***	T-17A	22	RVGD - ***	T-23A	19
RPGS - ***	T-3A	15	RSHC - 8**	T-17A	23	RVGD - 8**	T-23A	20
RPGT - ***	T-3A	10	RSHE - ***	T-17A	24	RVIA - ***	T-19A	16
RPIC - ***	T-16A	6	RSJC - ***	T-19A	22	RVIB - ***	T-19A	17
RPIC - 8**	T-16A	14	RSJC - 8**	T-19A	23	RVID - ***	T-24A	19
RPID - ***	T-16A	12	RSJE - ***	T-19A	24	RVID - 8**	T-24A	20
RPIS - 8**	T-16A	15	RVBA - ***	T-163A	16	SCCA - ***	T-11A	26
RPKC - ***	T-18A	6	RVBB - ***	T-163A	17	SCEA - ***	T-2A	26
RPKC - 8**	T-18A	14	RVCA - ***	T-11A	16	SCGA - ***	T-17A	26
RPKD - ***	T-18A	12	RVCB - ***	T-11A	17	SCIA - ***	T-19A	26
RQEB - ***	T-10A	11	RVCD - ***	T-21A	19	SQDB - ***	T-11A	27
RQGB - ***	T-3A	11	RVCD - 8**	T-21A	20	SQFB - ***	T-2A	27
RQIB - ***	T-16A	11	RVEA - ***	T-2A	16	SQHB - ***	T-17A	27
RQKB - ***	T-18A	11	RVEB - ***	T-2A	17	SQJB - ***	T-19A	27
RSBC - ***	T-163A	22	RVED - ***	T-22A	19	SXCA - ***	T-11A	25
RSDC - ***	T-11A	22	RVED - 8**	T-22A	20	SXEA - ***	T-2A	25
RSDC - 8**	T-11A	23	RVES - ***	T-2A	18			
RSFC - ***	T-2A	22	RVGS - ***	T-17A	18			

NOTES

NOTES

NOTES

WARRANTY INFORMATION, PERFORMANCE ASSURANCE, AND APPLICATION LIMITATIONS

Caution

Sun Hydraulics Limited manufactures a variety of cartridge valves that will fit into the same Sun cavity. Each cartridge is marked with a seven-digit part identification code and a four-digit date code, stamped on the hex surfaces. Designers and users of Sun components are advised that **physical interchangeability of cartridges does not necessarily mean functional interchangeability.** When

replacing any Sun cartridges, users should first check with the manufacturer's service literature, their local Sun distributor, or the Sun factory before making any part substitutions.

NOTE: To avoid serious injury, the manufacturer's service literature must be consulted before working on any hydraulic system.

Limited Warranty

Sun Hydraulics Limited warrants its products free from defects in material, workmanship, and design for a period of three years after their installation, provided the installation date is less than one year after manufacture. **“O-rings” and seals are specifically exempted from this warranty.** In no instance is there any warranty of fitness for a particular use and Sun Hydraulics Limited cannot and does not accept responsibility of any type for any of its products that have been subjected to improper installation, improper application, negligence,

tampering, or abuse, or which have been repaired or altered outside of the Sun Hydraulics factory. Sun's Limited's liability under this warranty shall extend only to repair or replacement, f.o.b. Sun's factory, of any defective part or product determined by inspection as not conforming to this warranty. Sun makes no other warranties, expressed or implied, and is not responsible for any consequential damages resulting from use by any buyer or user, Sun Hydraulics' liability being limited to the value of product sold or obligation to replace a defective part.

Performance Assurance

All Sun cartridges valves are individually tested at the factory and preset to specific pressure or flow settings where indicated in this catalogue. However, as the actual performance of buyers' equipment cannot be reproduced in Sun's testing laboratory, assurance of suitability of Sun products in the

buyer's application is the responsibility of the buyer. This is typically accomplished by the manufacture of a prototype followed by a test or qualification program on the part of the buyer.

Application Limitations

Sun product designs and manufacturing facilities have been specifically developed to provide products for commercial, industrial and mobile hydraulic applications and Sun products are only warranted for these types of uses. **Sun's distributors are not authorised to approve the use of Sun products in any of the following applications:**

- Any steering or braking systems for passenger-carrying vehicles or on-highway trucks.
- Aircraft or space vehicles.

- Ordnance equipment.
- Life support equipment.
- Any end product which is used in a nuclear power plant application.

Specific written approval for any application of Sun products in any of the above named applications should be obtained from Sun Hydraulics Limited. Consultation with Sun distributors or factory engineers is advisable in any situations where applicability is questionable.



Sun Hydraulics International Distribution



Worldwide Distributors

Country	Name	Telephone			Facsimile		
		(Dial International Access Code before number listed below)					
		Country Code	City Code	Local Number	Country Code	City Code	Local Number
Argentina	Verion I.C.S.A.	54	11	4754-0044	54	11	4755-7167
Australia	Simon Hydraulics & Pneumatics Pty. Limited, Queensland	61	7	3307-8200	61	7	3868-2315
Chile	Eximtec LTDA.	56	2	207-6590	56	2	207-6591
China	Sun Hydraulics Systems (Shanghai) Co., Ltd.	86	21	5778-0778	86	21	5778-0768
Hong Kong	Sun Hydraulics Systems (Shanghai) Co., Ltd.	86	21	5778-0778	86	21	5778-0768
India	Wipro Limited	91	80	839-4982	91	80	839-6450
Israel	Nahum Goldenberg NG, Ltd. Ashrad Systems Eng., Ltd.	972	3	534-7976	972	3	534-3049
		972	3	518-4443	972	3	683-2364
Japan	Kawasaki Heavy Industries, Ltd.	81	3	3435-6868	81	3	3435-2023
Korea	Sun Hydraulics Korea Corporation	82	32	813-1350	82	32	813-1147
Malaysia	Fluid Power (Pte.) Ltd.	65	*	254-7777	65	*	253-0319
New Zealand	Hydraulic Cartridge Valves, Ltd.	64	9	573-1051	64	9	573-1052
Peru	Powermatics S.A.	51	1	4349-4011	51	1	437-0073
Singapore	Fluid Power (Pte.) Ltd.	65	*	254-7777	65	*	253-0319
South Africa	Axiom Hydraulics (Pty.) Ltd.	27	11	334-3068	27	11	334-4543
Taiwan	Taiphil Pioneer Corporation	886	22	505-6992	886	22	500-7051
Thailand	Tavasin Limited Partnership	66	2	691-5900	66	2	691-5820

*No City Code Necessary

*No City Code Necessary

European Distributors

Country	Name	Telephone			Facsimile		
		(Dial International Access Code before number listed below)					
		Country Code	City Code	Local Number	Country Code	City Code	Local Number
Austria	Sun Hydraulik GmbH	49	2431	8091-0	49	2431	8091-19
Belgium	HCS-Koppen & Lethem SA/NA	32	2	361-7401	32	2	361-7405
Denmark	Hydropower A/S	45	75	144-444	45	75	144-545
Finland	Polarteknik PMC Oy Ab	358	9	878-080	358	9	878-0839-2
France	Koppen & Lethem S.A.R.L.	33	1	4147-5530	33	1	4147-5540
Germany	Sun Hydraulik GmbH	49	2431	8091-0	49	2431	8091-19
Iceland	Landvelar HF	354	5	576-600	354	5	578-500
Italy	Oleobi Srl	39	51	765-555	39	51	766-699
	Sun Hydraulik GmbH	49	2431	8091-0	49	2431	8091-19
Netherlands	Koppen & Lethem Aandrijftechniek BV	31	182	625-462	31	182	631-300
Norway	Hydranor A/S	47	3	286-5656	47	3	286-5655
Poland	Rockfin Sp. z.o.o.	48	58	621-2777	48	58	621-2144
	Bibus Menos Sp. z.o.o.	48	58	660-9570	48	58	661-7132
Portugal	Hidromac LDA	351	1	726-3011	351	1	726-9525
Spain	Ingenieria y Dist. Hidraulico	34	943	696-095	34	943	696-507
Sweden	JMS Systemhydraulik AB	46	31	727-68-20	46	31	727-68-37
	Hydnet AB	46	859	470-470	46	859	470-479
Switzerland	ATP Hydraulik AG	41	41	790-2533	41	41	790-4266
Turkey	NGR Hidrolik San.ve Tic Ltd.	90	312	385-6276	90	312	385-6278
United Arab Emirates	Hydrolink Co., Ltd.	971	6	528-0801	971	6	528-0830
United Kingdom	Sun Hydraulics Limited	44	2476	217-400	44	2476	217-488